

Ternary Copolymerization of Supercritical CO₂, Propylene Oxide and Maleic Anhydride and Properties of Polycarbonates

Lan ZHENG^{1*}, Kecun LIU², Yuqi WANG¹, An FAN¹

¹ School of Chemical Engineering, Northwest University, 229# North Taibai Road, Xi'an, 710069, China

² Shaanxi Xianyang Chemical Industrial Co. Ltd, North Chaoyang Road, Xianyang, 712000, China

crossref <http://dx.doi.org/10.5755/j01.ms.23.4.17323>

Received 23 December 2016; accepted 13 April 2017

With zinc glutarate loaded molecular sieve catalyst in supercritical CO₂, the copolymerization of CO₂, propylene oxide, and maleic anhydride was studied in detail. The optimum conditions of copolymerization are: T = 70 °C, P = 8 MPa, reaction time 15 hours, 0.7 g catalyst per 20 ml propylene oxide, and product yield is 26 %. The functional polymer products have some special characteristics, such as high glass transition temperature and good tensile strength. It is biodegradable so that it can gradually replace the traditional plastic. The structure of the copolymer products was characterized by FTIR, ¹H-NMR, ¹³C-NMR, and SEM analysis.

Keywords: supercritical CO₂, propylene oxide, ternary copolymerization, maleic anhydride, loaded molecular sieve catalyst.

1. INTRODUCTION

Polycarbonate (PC) is one of the general engineering plastics with rapid growth of demand for its high purity, high transparency, and good comprehensive performance. It is widely used in automobile manufacturing, construction, packaging, medical care, household items, aviation, aerospace, computer, and more. In the next three years, the global PC demand will grow about 3.9 %, and the quantity demanded will reach 4.573 million tons in 2019 [1]. According to different synthetic polymer monomer, PC can be divided into aromatic, aliphatic, fat-aromatic hybrid three, or other types. Aliphatic polycarbonate (APC) is a biodegradable polymer, which can degrade to neutral dibasic alcohol and carbon dioxide. Because of their relatively low surface corrosion degradation rate in water, their more amorphous nature and good biological compatibility, and the ease to introduce lateral (reactive) functionality with less waste pollution to the environment, APCs offer many advantages [2].

A new polymerization process on biodegradable materials synthesis is used to get APC: reacting CO₂ and epoxides under the action of organometallic catalyst. It opened up an effective way of chemical CO₂ fixation and soon became a hot spot on macromolecule catalytic synthesis of polymers [3–9]. Supercritical CO₂ has high mass transfer and heat transfer speed. A series of excellent properties, such as directly strengthening the contact of reactants, shortening reaction time, and developing a narrower molecular weight distribution for the product by using supercritical CO₂ as reactant and solvent in polymerization [10–18]. In the face of such opportunities and challenges, it is a good industrialization prospect for the research on synthesis of polycarbonate in supercritical CO₂.

In the current work, the ternary copolymerization of CO₂, propylene oxide, and maleic anhydride was realized in supercritical CO₂, which was used as reactant and solvent. APC was got under the action of zinc glutarate loaded on molecular sieve catalyst. An investigation was also conducted on the thermal stability, biodegradable properties, and mechanical properties of the copolymer.

2. EXPERIMENTAL

2.1. Materials

The materials used in the copolymerization are shown in Table 1.

Table 1. Materials

Materials	Standard	Manufacturer
Glutamic acid	Analytically pure	Sinopharm chemical reagent Co. Ltd
Zinc oxide	Analytically pure	Xi'an chemical reagent factory
Molecular sieve	4 A	Third factory of Tianjin chemical reagent
Carbon dioxide	≥ 99.99%	Shaan Xi XingPing chemical plant
Propylene oxide	Analytically pure	Sinopharm chemical reagent Co. Ltd
Maleic anhydride	Analytically pure	Guangdong Xilong chemical Co., Ltd

2.2. Preparation of catalysts

First, zinc glutarate was obtained by the reaction of glutamic acid and zinc oxide. Then, a certain amount of zinc glutarate was dissolved in anhydrous ethanol and loaded on activated molecular sieve carrier by the impregnation method. For 20 minutes under 1000 r·min⁻¹, the sample was centrifugal separated, vacuum filtrated, and then dried under 150 °C for an hour. The loaded molecular sieve catalyst was obtained subsequent to grinding and

* Corresponding author. Tel.: +0086-13709257608.
E-mail address: lanny@nwu.edu.cn (L. Zheng)

roasting. FTIR spectrum and SEM test shows that the main catalyst zinc glutarate is loaded successfully on the molecular sieve carrier; the catalyst has a large specific surface area.

2.3. Copolymerization

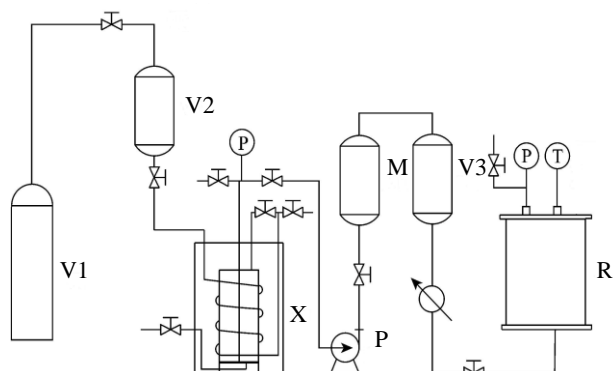

Fig. 1. Experimental flow sheet of SC-CO₂ reaction: V1–CO₂ cylinder; V2, V3–purifiers; M–mixer; X–cooler; R–reactor; P–high pressure pump

Huaan Supercritical Extraction Co. Ltd created the primary devices for supercritical fluid reaction, as shown in Fig. 1. A certain amount of loaded molecular sieve catalyst, activated epoxy propane and maleic anhydride, were put in the high-pressure reaction kettle. For 30 minutes, CO₂ was used to displace the air of the kettle and shut off the import and export valves. Start the blender at 600 r·min⁻¹, then heat and boost to the setting temperature and pressure. For five to six hours, keep reacting. After cooling and pressure discharging, the solid terpolymer of CO₂, propylene oxide and maleic anhydride was obtained, which is white and loose. Remove the products for purification.

2.4. Characterization of copolymer

Sample of product was analyzed by EQUINOX-55 Infrared Spectrometer (Brooke company, Germany), ZQ UPLC-ESI-MS Mass Spectrometer (Waters company, United States), and INOVA-400MHz NMR Spectrometer (Varian company, United States). TGA/SDTA851 Thermogravimetric Analyzer (METTLER TOLEDO Company, Swiss) and NETZSCH DSC 206 (NETZSCH, company, United States) analyzed the thermal stability. PL-GPC 220 (Polymer Laboratories Ltd, tetrahydrofuran as eluent, polystyrene as standard samples, elution velocity: 1.00 mL/min) was used to obtain the product's relative molecular mass. S-570 Scanning Electron Microscopy (SEM, Hitachi LTD, Japan.) was used to observe the product's morphology.

3. RESULTS AND DISCUSSION

The synthesis of terpolymer is described in Fig. 2. In this work, the third monomer MA was introduced into the copolymerization of CO₂ and PO, and MA was activated by anionic coordination catalyst ZnGA.

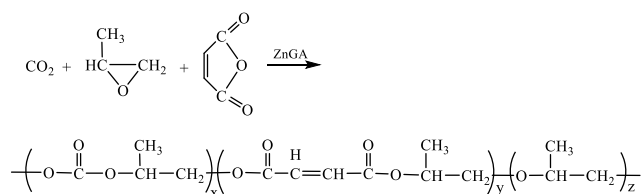

Fig. 2. Terpolymerization of carbon dioxide, propylene oxide and maleic anhydride

3.1. Effects of temperature and pressure on reaction yield

The reaction yield X was defined as

$$X = \frac{\text{weight of polymer}}{\text{weight of propylene oxide}} \times 100\% \quad (1)$$

Fig. 3 shows the effects of temperature on reaction yield of polymerization in Supercritical CO₂. It can be seen by the figure that as the reaction temperature increased from 40 °C to 70 °C, the reaction yield continuously increased. This is because catalyst activity gradually increases with the increase in temperature. On the contrary, the reaction yield decreases as the temperature rose up to 70 °C. This is due to the deactivation of catalysts when the temperature was above a certain degree. Meanwhile undesired reactions at higher temperature (loss of selectivity) and increasing decomposition of product also contributes to the lost of reaction yield.

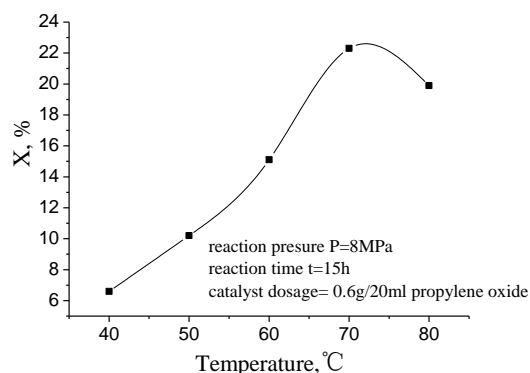

Fig. 3. Influence of reaction temperature on reaction yield

3.2. Effects of pressure on reaction yield

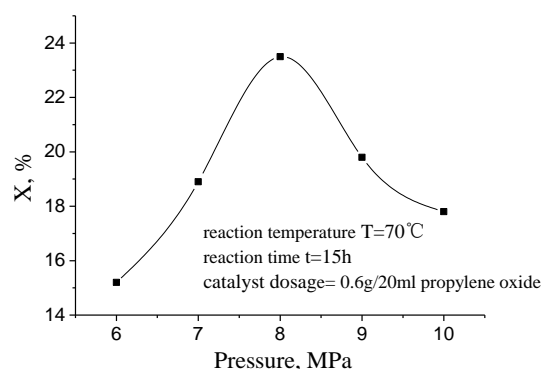

Fig. 4. Influence of reaction pressure on reaction yield

Fig. 4 shows the effects of pressure on reaction yield of polymerization in Supercritical CO₂. It can be seen that as the reaction pressure increases from 6 to 8 MPa, the reaction yield increases. This is because CO₂ gradually changes to a liquid state as the reaction pressure increases, and the reaction with propylene oxide and maleic anhydride is similar to liquid-liquid reaction. Therefore, the reaction happened easier by eliminating interface resistance. Thus the reaction yield gradually reduces with the increase of pressure from 8 to 10 MPa. This may be due to high pressure on the surface of the catalyst, which makes it difficult to separate reaction products from the surface of the catalyst, hindering the reactant and catalyst contact. As a result, the reactant cannot be activated and the reaction cannot take place successfully.

3.3. Effects of reaction time on reaction yield

Fig. 5 shows the relationship between reaction time and ternary copolymerization yield. It shows that as time goes from 10 to 15 hours, the copolymerization reaction yield increases.

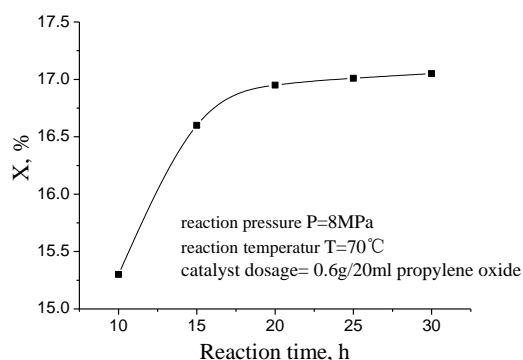

Fig. 5. Influence of reaction time on reaction yield

This is because as the time extends, the activation of reactants increase, and the reaction rate is accelerated accompanied by the increasing target polymer product. When the reaction time is above 15 hours, the catalyst activity and the activation of reactants decreases; the reaction reaches equilibrium. Therefore, after 15 hours, copolymerization of CO₂, propylene oxide, and maleic anhydride can be determined. The reaction time is greatly shortened when compares with a reaction time of 25 to 40 hours under low pressure [3–7]. This is benefit from the properties of supercritical CO₂. High density and solubility of supercritical CO₂ makes it easy to blend with epoxy propane, maleic anhydride, and loaded catalyst. The reaction easily activates. On the other hand, the mass transfer of supercritical CO₂ is very fast for its gas characteristics, allowing CO₂ to quickly separate from the catalyst, reducing the activation and reaction time. Consequently, supercritical CO₂ system is suitable for copolymerization of CO₂, propylene oxide, and maleic anhydride.

3.4. Effects of catalyst dosage on copolymerization

Fig. 6 shows the influence of the catalyst dosage on the copolymer yield. From the nature of the catalyst, it can be seen that the amount of copolymer increased with the increasing of the amount of catalyst before it reaches

appropriate amount 0.7 g/20 ml propylene oxide. This is because the reaction rate was faster when the more reactants are activated, leading to more copolymers being produced. The reaction rate doesn't change when the catalyst amount reaches a certain value; the peak quantity of the copolymer is reached, therefore it no longer increases.

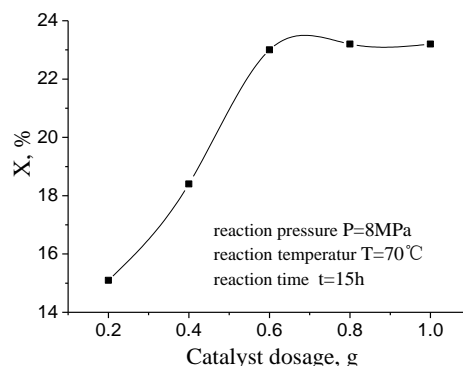

Fig. 6. Influence of catalyst dosage on reaction yield

3.5. Effects of maleic anhydride dosage on copolymerization

Fig. 7 and Fig. 8 show the influences of the additional amount of maleic anhydride on the yield of copolymer and polymer relative molecular mass at 70 °C, 8 MPa for about 15 h with the catalyst dosage of 0.6 g/20 ml propylene oxide. With the addition of maleic anhydride, the production rate is higher when compared with binary copolymerization of CO₂ and propylene oxide. This is due to the carbonyls on both ends of maleic anhydride. This characteristic promotes the reaction of esterification and makes the activation easier. Consequently, the growth of the chain is realized, and the ternary copolymerization reaction yield increases. Under the influence of the space steric hindrance, when the amount of maleic anhydride increases to more than 2.5 g/20 ml propylene oxide, the copolymerization reaction was hindered, which led to a decline in the reaction yield.

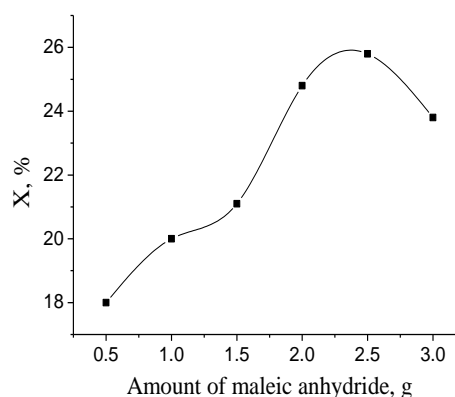

Fig. 7. Influence of maleic anhydride amount on reaction yield

It can be seen from Fig. 8, the polymer's relative molecular mass increased with the increase of maleic anhydride. The molecular weight of the copolymer increases when compared with the bipolymer. This is due to the increase of polycarbonate polymerization degree with the introducing of maleic anhydride monomers.

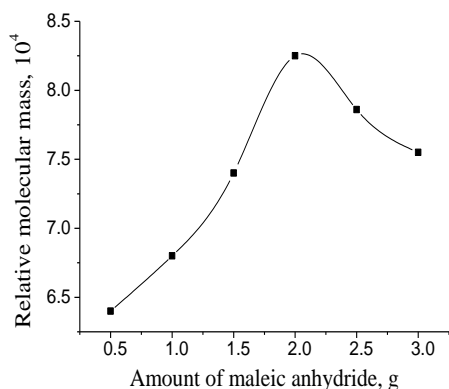

Fig. 8. Influence of maleic anhydride amount on product relative molecular mass

First, the molecular weight increases with the increase of maleic anhydride. The copolymer reached the maximum molecular weight when the amount of maleic anhydride monomer reached 4 g. Once it increased to more than 4 g, the polycarbonate molecular weight has a tendency to decrease. This is a result of space steric hindrance with the introducing of maleic anhydride, which resulted in reducing the degree of polymerization reaction and led to lower molecular weight of reaction product.

4. STRUCTURE ANALYSIS OF COPOLYMER

4.1. FTIR spectrum of the copolymer

Fig. 9 shows the Fourier transformation absorption spectrum infrared of the copolymer. Characteristic absorption peaks of the copolymer can be seen from the picture, which in turn are 1537 cm⁻¹, 1230 cm⁻¹, 2985 cm⁻¹, and 1735 cm⁻¹. Identification of characteristic peaks at 1230 cm⁻¹ shows single carbon-oxygen bond (C-O) in copolymers; identification characteristic peaks at 1735 cm⁻¹ shows double carbon-oxygen bond (C=O) in copolymers; identification characteristic peaks at 2985 cm⁻¹ is the characteristic peak of resonance between methyl (CH₃-) and methylene (CH₂-). Between the characteristic peaks of the 1735 cm⁻¹ and 1537 cm⁻¹, there is a peak of 1640 cm⁻¹; it is the characteristic peaks of carbon-carbon double bond, which shows the third maleic anhydride monomer has been involved in the reaction. This indicated the success of polypropylene carbonate.

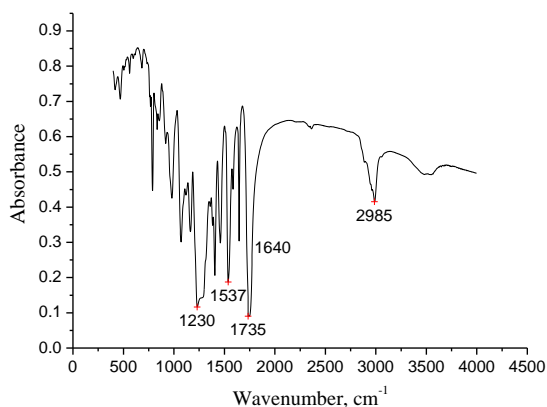

Fig. 9. FTIR spectrum of copolymer

4.2. Morphology of copolymer

The surface characteristics were observed by the scanning electron microscope (SEM) subsequent to the purification and crystallization of the copolymer, which is shown in Fig. 10.

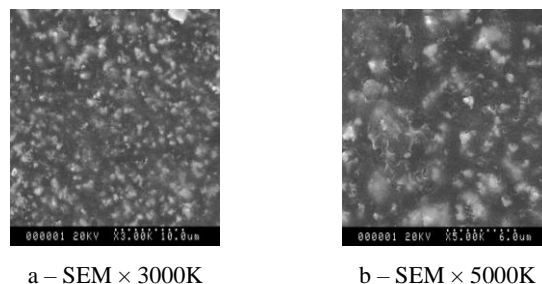

Fig. 10. SEM micrographs of terpolymer

4.3. ¹H-NMR analysis of copolymer

The ¹H-NMR analysis of the terpolymer is shown in Fig. 11.

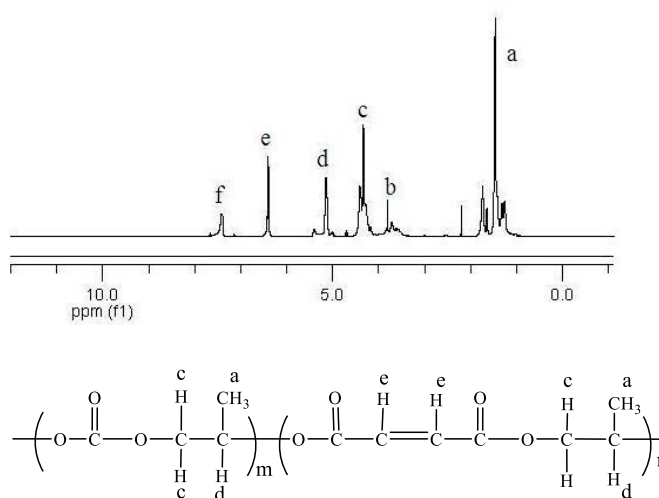

Fig. 11. ¹H-NMR spectrum of copolymer and location of H in the structural formula

As shown in Fig. 11, ¹H-NMR graph corresponds to the location of the structural formula of H. Combined with infrared spectra, the copolymer is built by CO₂, propylene oxide and maleic anhydride polycondensation. It shows the corresponding characteristic peaks and membership of each H.

The ether bond resonance peak b appears between δ=3.5ppm and δ=3.7ppm. The formant of δ=6.2ppm convincingly shows that maleic anhydride has successfully been introduced to the copolymerization reaction of carbon dioxide with propylene oxide.

4.4. ¹³C-NMR analysis of copolymer

¹³C-NMR analysis of terpolymer is shown in Fig. 12. In the ¹³C-NMR graph, the corresponding characteristic peaks with membership of each C is shown. All these fully explained that maleic anhydride has been successfully introduced into the copolymer.

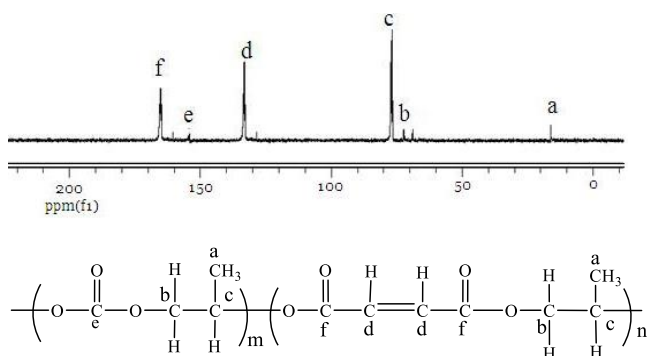

Fig. 12. Typical ^{13}C -NMR spectrum of copolymer and location of C in the structural formula

4.5. Thermal stability and biodegradable properties of the copolymer

The thermogravimetric analyzer analyzes the thermal stability of ternary copolymer with maleic anhydride modified and untreated binary copolymer of CO_2 and the propylene oxide in nitrogen protection system. Fig. 13 and Fig. 14 shows the results.

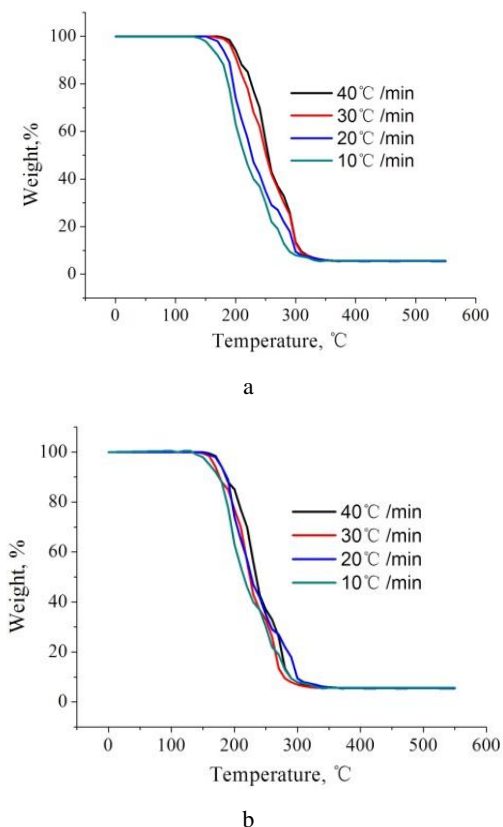

Fig. 13. Thermal stability of ternary copolymer and untreated binary copolymer with different heating rate: a – thermal stability of ternary copolymer; b – thermal stability of untreated binary copolymer

Fig. 13 shows that the thermal-decomposition temperature of the untreated binary copolymer is about 145°C , while the thermal-decomposition temperature of the ternary copolymer is 165°C . It indicates that the ternary copolymer is more stable. In Fig. 14, glass transition temperature rises slightly, this may be due to the falling of molecular activity with the existence of long branches chain structure. This indicates that maleic

anhydride is effective for sealing and modification of polycarbonate (PC); inhibit the thermal degradation of PC.

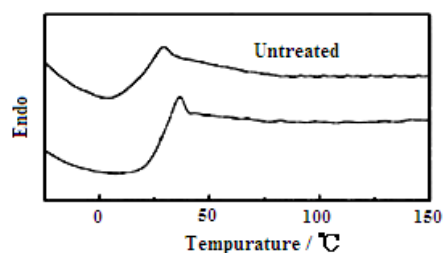

Fig. 14. DSC curves of ternary copolymer and untreated binary copolymer

4.6. Biodegradable properties of the ternary copolymer

After weighed, the preforming polymer membrane was put into 50 ml 0.1M Tris-HCl, pH7.4 buffer solution at 37°C to observe the biodegradable properties. Fig. 15 shows the weightless rate change with time. It can be seen that the ternary copolymer has good degradation ability in simulative city water. The degradation rate gradually increased with the extension of degradation time.

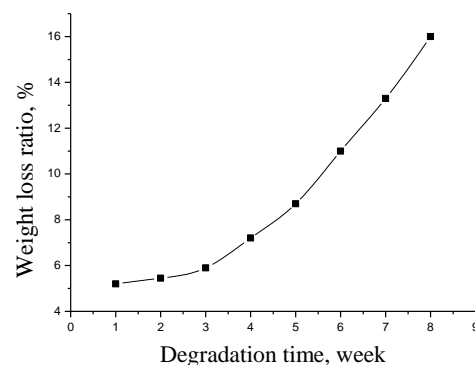

Fig. 15. Biodegradable properties of the copolymer

4.7. Mechanical properties of the copolymer

Table 2 shows different performing samples tensile strength and elongation at break. It is noticed that the modified ternary copolymer greatly improves the tensile strength and the elongation at break.

Table 2. Mechanical properties testing results of binary copolymer and modified ternary copolymer samples

Sample	Tensile strength, MPa	Elongation at break, %
Binary copolymer of CO_2 and propylene oxide	5.65	248
Ternary copolymer with maleic anhydride modified	7.43	392

5. CONCLUSIONS

1. Ternary copolymerization of Supercritical CO_2 , propylene oxide, and maleic anhydride was successfully realized in supercritical CO_2 . FTIR, ^1H -NMR, ^{13}C -NMR and SEM characterized the structure of the copolymer. The synthesis method of polymers

in supercritical CO₂ is simple, safe, and environmentally protected; it avoids the wide use of poisonous organic solvent in the traditional process. Because of its low cost, the technology is competitive.

- Through the study of the effects of copolymerization temperature pressure and percent conversion time of CO₂, and propylene oxide, the optimal reaction conditions is 70 °C, 8 MPa, reaction time 15 h, catalyst dosage 0.7 g/20 ml propylene oxide. The copolymerization yield of oxygen propane is up to 26 %. Compared with previous research [5], reaction time is shortened from 40 h to 15 h.
- The thermodynamic properties of the polymer are improved with the addition of the third component-maleic anhydride. The ternary copolymer has good tensile strength of 7.43 MPa. It is biodegradable so that it can gradually replace the traditional plastic. As a new kind of biodegradable material, it has a good prospect of industrialization.

Acknowledgments

This paper is supported by Special fund of Education Department of Shaanxi Provincial Government 16JK1764.

REFERENCES

- 2016-2022 China Polycarbonate Industry Development Status and Development Prospects Report: pp. 125–139
- Mespouillea, L., Coulembiera, O., Kawaleca, M., Doveb, A.P., Dubois, P. Implementation of Metal-Free Ring-Opening Polymerization in the Preparation of Aliphatic Polycarbonate Materials *Progress in Polymer Science* 39 (6) 2014: pp. 1144–1164.
- Liu, Y.F., Huang, K.L., Peng, D.M., Wu, H. Synthesis, Characterization and Hydrolysis of an Aliphatic Polycarbonate by Terpolymerization of Carbon Dioxide, Propylene Oxide and Maleic Anhydride *Polymer* 47 (26) 2006: pp. 8453–8461.
- Song, P.F., Xiao, M., Du, F.G., Wang, S.J., Gan, L.Q., Liu, G.Q., Meng, Y.Z. Cross-Linkable and Thermally Stable Aliphatic Polycarbonates Derived from CO₂, Propylene Oxide and Maleic Anhydride *Journal of Polymer Research* 16 (2) 2009: pp. 91–97. <https://doi.org/10.1007/s10965-008-9206-2>
- Song, P.F., Xiao, M., Du, F.G., Wang, S.J., Gan, L.Q., Liu, G.Q., Meng, Y.Z. Synthesis and Properties of Aliphatic Polycarbonates Derived from Carbon Dioxide, Propylene Oxide and Maleic Anhydride *Journal of Applied Polymer Science* 109 (6) 2008: pp. 4121–4129. <https://doi.org/10.1002/app.28449>
- Sakakura, T., Saito, Y., Okano, M., Choi, J.C., Sako, T. Selective Conversion of Carbon Dioxide to Dimethyl Carbonate by Molecular Catalysis *Journal of Organic Chemistry* 63 (2) 1998: pp. 7095–7096.
- Li, X.H., Meng, Y.Z., Wang, S.J., Rajulu, A.V., Tjong, S.C. Completely Biodegradable Composites of Poly(propylene carbonate) and Short, Lignocellulose Fiber *Hildegardia populifolia Journal of Polymer Science Part B-Polymer Physics* 42 (4) 2004: pp. 666–675. <https://doi.org/10.1002/polb.10761>
- Ballivet-Tkatchenko, D., Chambreya, S., Keiskib, R., Ligabuea, R., Plasserauda, L., Richarda, P., Turunen, H. Direct Synthesis of Dimethyl Carbonate with Supercritical Carbon Dioxide: Characterization of a Key Organotin Oxide Intermediate *Catalysis Today* 115 (1–4) 2006: pp. 80–87.
- Lu, H.L., Diao, C.X., Chen, J., Xu, J.L. The Synthesis Technology and Development Prospect of Polycarbonate *Technology & Economics in Petrochemicals* 29 (2) 2013: pp. 59–62.
- Li, Y.F., Wu, X.M. Production Technology Progress and Market Analysis of Polycarbonate at Home and Abroad *Shanghai Chemical Industry* 38 (4) 2013: pp. 31–37.
- Xu, P.X. Making Polycarbonates from CO₂ and Epichlorohydrin by Stereoselective Copolymerization. Dalian University of Technology, 2013.
- Li, X.H., Tjong, S.C., Meng, Y.Z., Zhu, Q. Fabrication And Properties of Poly(Propylene Carbonate)/Calcium Carbonate Composites *Journal of Polymer Science Part B-Polymer Physics* 41 (15) 2003: pp. 1806–1813. <https://doi.org/10.1002/polb.10546>
- Du, L.C., Meng, Y.Z., Wang, S.J., Tjong, S.C. Synthesis and Degradation Behavior of Poly(Propylene Carbonate)Derived from Carbon Dioxide and Propylene Oxide *Journal of Applied Polymer Science* 92 (3) 2004: pp. 1840–1846.
- Byrnes, M.J., Chisholm, M.H., Hadad, C.M. Mechanistic Studies of the Copolymerization Microstructural of Propylene Oxide and Carbon Dioxide Approach *Abstracts of Papers* 226th ACS National Meeting 2003.
- Buchard, A., Jutz, F., Kember, M.R., White, A.J.P., Rzepa, H.S., Williams, C.K. Experimental and Computational Investigation of the Mechanism of Carbon Dioxide/Cyclohexene Oxide Copolymerization Using a Dizinc Catalyst *Macromolecules* 45 (17) 2012: pp. 6781–6795.
- Ikpo, N., Flogera, J.C., Kerton, F.M. Aluminium Coordination Complexes in Copolymerization Reactions of Carbon Dioxide and Epoxides *Dalton Transactions* 42 (25) 2013: pp. 8998–9006.
- Diciccio, A.M., Coates, G.W. Ring-Opening Copolymerization of Maleic Anhydride with Epoxides: A Chain-Growth Approach to Unsaturated Polyesters *Journal of American Chemical Society* 2133 (28) 2011: pp. 10724–10727.
- Inoue, S., Koinuma, H., Tsuruta, T. Copolymerization of Carbon Dioxide and Epoxide with Organometallic Compounds *Makromolekulare Chemie* 130 (1) 2003: pp. 210–220.
- Seong, J.E., Na, S.J., Cyriac, A., Kim, B.W., Lee, B.Y. Terpolymerizations of CO₂, Propylene Oxide, and Various Epoxides Using a Cobalt(III) Complex of Salen-Type Ligand Tethered by Four Quaternary Ammonium Salts *Macromolecules* 43 (2) 2010: pp. 903–908.
- Darensbourg, D.J., Moncada, A.I., Choi, W., Reibenspies, J.H. Mechanistic Studies of the Copolymerization Reaction of Oxetane and Carbon Dioxide to Provide Aliphatic Polycarbonates Catalyzed by (Salen)Crx Complexes *Journal of the American Chemical Society* 130 (20) 2008: pp. 6523–6533. <https://doi.org/10.1021/ja800302c>
- Wang, D. Preparation and Modification of Biodegradable Poly(propylene carbonate) and Its Melt Blending Fibers, Shanghai, Donghua university, 2014: pp. 17–43.