

Increasing of Carbon Steel Durability by Surface Hardening

Vytautas ČIUPLYŠ^{1*}, Antanas ČIUPLYŠ¹, Jonas VILYS¹, Valdas KVEDARAS²

¹Department of Manufacturing Technologies, Kaunas University of Technology, Kęstučio 27, LT-44312 Kaunas, Lithuania

²Department of Technological Processing, Klaipėda University, Bijūnų 17, LT-91225 Klaipėda, Lithuania

Received 27 February 2009; accepted 26 February 2010

Conditions of machine elements during exploitation, also durability and security of all construction depends a lot on the state of metals surface layer. Hardening of metals surface allows to change expensive metals to cheap ones. Improvement of surface quality allows to increase the durability of all construction. In this work the influence of various kinds of surface treatments (hardening with high frequency electric current, rolling by rollers, tempering) on fatigue strength of carbon steel specimens were investigated. Analysed technology of surface hardening greatly increases the fatigue strength and durability of specimens. It was estimated that hardening effect depends on the residual stresses introduced applying deformation and thermal treatment regimes. The optimal treatment of the analysed carbon steel is deformation up to 1 mm depth, hardening with high-frequency electric current and tempering for 2 hours at 200 °C.

Keywords: carbon steel, fatigue, surface hardening, mechanical properties, durability.

1. INTRODUCTION

Analysing plastic deformation and failure processes of metal materials, usually the following factors are discussed: material structure, deformation rate, temperature, etc. However, the influence of surface layers on deformation process is taken into account very seldom, though they very often influence the mechanical properties, mechanisms of plastic deformation and failure [1].

Operational properties of a part, reliability and durability of the whole construction much depend on the state of metal surface layers. When manufacturing parts of cars, elements of important constructions and technological software, usually there is an objective to obtain a very strong, solid and resistant to wear surface, leaving a softer and more plastic core. This is beneficial from technological as well as economical point of view since cheaper metal is used, whereas mechanical properties remain good [2].

Fatigue strength is one of the most important mechanical properties [3]. Durability and reliability of car parts is often defined by their fatigue strength, since most of them are loaded with dynamic, repeating or variable loads and the main type of failure is metal fatigue.

Failure of fatigue usually starts on the metal surface. This is related with the fact that the most intensive fatigue plastic deformation occurs in the surface of one grain thickness metal layer [2]. State and properties of the layer determine durability before the occurrence of fatigue crack. The interrelationship of the surface layer together with the characteristics of internal metal volume determine the value of fatigue limit and the coefficient level of stresses' intensity, which is necessary for the start of fatigue crack [4 – 8].

Various hardening methods of surface have a huge influence on fatigue strength of structural materials [9, 10]. The choice of surface treatment method is determined by properties and microstructure of a material, as well as the

purpose and working conditions of part's material. Very often the optimum treatment is a combination of several methods, which enables to obtain the required properties (high fatigue strength, wear, etc.) [11 – 15].

The surface layer of metal has a huge influence on mechanical properties, plastic deformation and failure mechanisms, thus when manufacturing parts it is very important to form the surface layer of required properties on their surface. Steel's fatigue strength may be increased using different surface hardening methods [16 – 20]. Various methods may be used: plastic deformation (rolling by rollers and balls, shot peening), surface hardening, laser and plasma treatment, thermal and thermo-chemical treatment and their different combinations. Selection of one method or the other depends on the specific operational conditions of the part.

Hardening with high-frequency electric current (HfEC) is widely used process for the surface hardening of steel. The components are heated by means of an alternating magnetic field to a temperature within or above the transformation range followed by immediate quenching. The core of the component remains unaffected by the treatment and its physical properties are those of the bar from which it was machined. Carbon and alloy steels with an equivalent carbon content in the range 0.40/0.45 % are most suitable for this process [21].

The purpose of the work was to investigate the influence of several combined surface treatments on the fatigue strength of carbon steel samples.

2. EXPERIMENTAL

Chemical composition and mechanical characteristics of the investigated steel are given in Table 1 and Table 2.

Table 1. Chemical composition of steel (in wt. %)

C	Si	Mn	Cr	P	S	Cr	Cu
0.45	0.24	0.60	0.20	0.032	0.030	0.20	0.10

*Corresponding author. Tel.: +370-37-300420, fax.: +370-37-323769.
E-mail address: vytautas.ciuplys@ktu.lt (V. Čiuplys)

Table 2. Mechanical characteristics of the investigated steels

$R_{p0.2}$, MPa	R_m , MPa	A , %	Z , %
335	650	14	40

The surface was hardened using three different surface treatment combinations: by hardening with HfEC, rolling by rollers, tempering under different temperatures.

A source of high-frequency electricity was used to drive a large alternating current through a coil. The passage of current through this coil generates a very intense and rapidly changing magnetic field in the space within the work coil. The samples to be heated were placed within this intense alternating magnetic field where eddy currents are generated within the sample and resistance leads to heating of the metal.

A high-frequency generator “BTГ-10-66” (Termolit, Ukraine) was used in this work. Output power was 3.5 kW, operating frequency – 53 kHz. The surface of the samples was heated up to 910 °C and then immediately quenched.

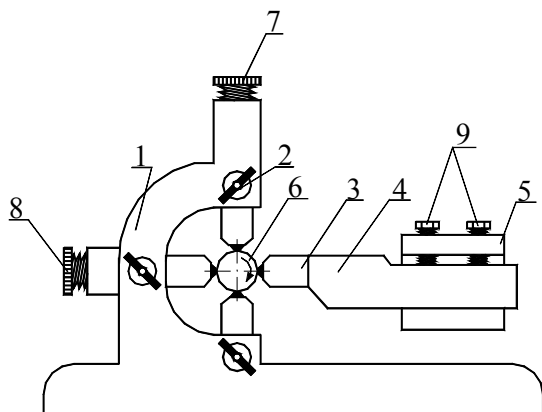

Fig. 1. Schematic diagram of a special device for round cross-section specimens' hardening: 1 – housing; 2 – fixing screw; 3 – controllable squeezer; 4 – holder; 5 – support; 6 – sample; 7, 8 – controllable screws; 9 – fixing screws

Rolling by rollers was accomplished with a special device for round cross-section specimens' hardening (Fig. 1). Round samples were used, the diameter of gauge length of which was equal to 7.5 mm and 10 mm. After the mechanical treatment, all samples were annealed at 850 °C in the protective environment. The samples with the diameter of gauge length 7.5 mm were hardened to the depth of hardened surface layer 0.5 mm and the samples with the diameter of gauge length 10 mm – to 0.7 mm. The depth of hardened surface layer was determined using magnetic Barkhausen noise [22].

Fatigue strength was investigated on the experimental device “УКИ-10М” (Tochpribor, Russia) by rotating in cyclic bending. The experiments were carried out at room temperature and at a rate 3000 r/min.

Steel's fatigue strength was investigated using 10 series samples. The treatment regimes are given in Table 3.

3. EXPERIMENTAL RESULTS AND DISCUSSION

According to the surface hardening regimes, presented in Table 3, fatigue curves of the treated samples are

presented in Fig. 2 and Fig. 3. The numbers of curves correspond to the numbers of sample series provided in Table 3.

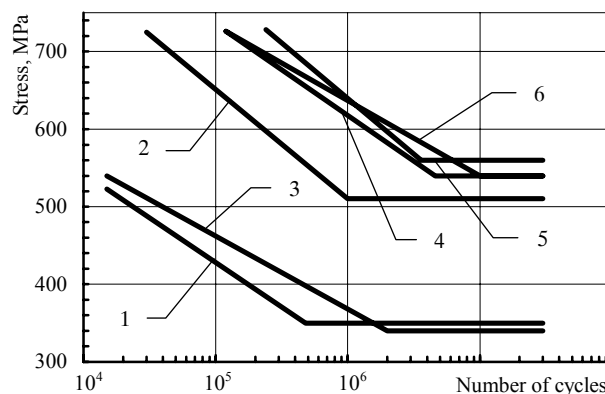

Fig. 2. Fatigue strength of 7.5 mm samples subject to surface hardening. The curves are numbered according to the numbers of series in Table 3

From the curves in Figs. 2 and 3 it can be seen that the surface hardening increases fatigue strength and durability of carbon steel samples. Rolling samples of series 2 by rollers, their fatigue strength, comparing with the rollers, their fatigue strength, comparing with the unhardened samples of series 1, increased by 160 MPa, whereas the durability at 520 Ma stress increased almost 100 times^S (Fig. 2, curves 1 and 2). Plastic deformation changes the structure and density of crystal boundaries defects of the surface layer, besides, the residual compression stresses are formed on the surface therefore fatigue strength increases [23].

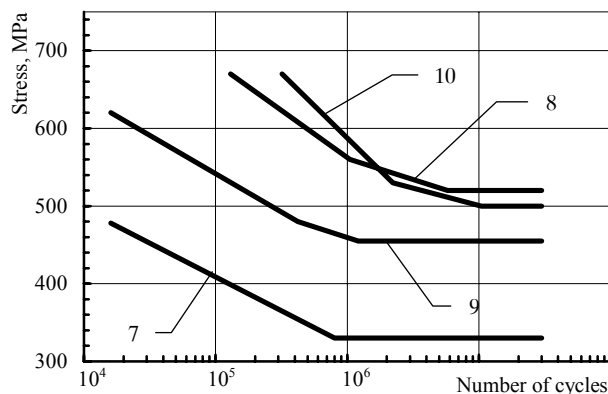

Fig. 3. Fatigue strength of 10 mm samples subject to surface hardening. The curves are numbered according to the numbers of series in Table 3

After rolling by rollers and hardening of samples with HfEC, their fatigue strength decreases. Fatigue limit decreases to 340 MPa, however durability increases, comparing with the unhardened samples of series 1 (Fig. 2, curves 1 and 3). After treating samples with the regime of series 3 and 2 h tempering at 200 °C, fatigue strength and durability significantly increase (Fig. 2, curve 4). The fatigue limit of samples of series (4–540) MPa 1.5 times

Table 3. Hardening methods, treatment regimes and fatigue limit of steel surface

Series No	Hardening regimes of the surface	Diameter of gauge length of the sample, mm	Fatigue limit, MPa
1	The unhardened sample is annealed for 6 hours at 850 °C	7.5	350
2	The unhardened sample + rolling by rollers	7.5	510
3	The unhardened sample + rolling by rollers + hardening with HfEC	7.5	340
4	The unhardened sample + rolling by rollers + hardening with HfEC + 2 h tempering at 200 °C	7.5	540
5	The unhardened sample + rolling by rollers + 6 h tempering at 500 °C + hardening with HfEC + 2 h tempering at 200 °C	7.5	560
6	The unhardened sample + rolling by rollers + 2 h tempering at 300 °C + hardening with HfEC + 2 h tempering at 200 °C	7.5	540
7	The unhardened sample is annealed for 6 hours at 850 °C	10	330
8	The unhardened sample + rolling by rollers + hardening with HfEC + 2 h tempering at 200 °C + smoothing	10	520
9	The unhardened sample + rolling by rollers + hardening with HfEC + 2 h tempering at 200 °C + smoothing + 1 h tempering at 300 °C	10	455
10	The unhardened sample + rolling by rollers + hardening with HfEC + 2 h tempering at 200 °C	10	500

exceed the fatigue limit of unhardened samples, whereas durability at 550 MPa increased by 1000 times.

The additional surface hardening treatment with high (series 5) or low (series 6) tempering, which is performed after rolling by rollers, does not demonstrate a more visible change of fatigue limit, comparing with the samples of series 4. Only after tempering samples for 6 hours at 500 °C, fatigue limit and durability increase insignificantly (Fig. 2, curves 4 and 5). Taking into account fatigue strength of samples of series 4, 5, and 6 it is difficult to give importance to any of them. The most economical one is treatment of samples of series 4 since after rolling by rollers tempering is not applied to them, which is used for the samples of series 5 and 6.

Surface hardening of samples with 10 mm diameter of gauge length (series 7–10) was carried out according the most effective treatment technology of samples of series 4 (series 10) with further smoothing (series 8) and the smoothing with a 1 hour tempering at 300 °C (series 9).

As can be seen from Fig. 3, the smoothing in the final surface hardening stage, comparing with the samples, which do not involve this kind of technological operation (series 10), increase the fatigue limit by 20 MPa (series 8). However after the smoothing carrying out a one hour tempering at 300 °C (series 9) fatigue strength of samples decreases. The fatigue limit of samples of series 9, comparing with the samples of series 10, decreased by 45 MPa, whereas durability decreases more than 10 times.

Curves 4 (Fig. 2) and 10 (Fig. 3) show the influence of scale factor on fatigue strength for the samples, which have a different diameter of gauge length and an equally hardened surface. The fatigue limit of 7.5 mm diameter samples (series 4) is 40 MPa higher than the fatigue limit of 10 mm diameter samples (series 10).

From the fatigue curves of Fig. 2 and 3 it can be seen that in order to increase the fatigue strength of the given steel, the most useful way is to harden its surface according technological regimes of series 4 and 10. Samples of the

series differ according the diameter of gauge length, however, their fatigue strength increased mostly when comparing with the samples, the gauge length surface of which had not been hardened. This is related with the optimal relation of properties and microstructure of the surface and internal samples [24]. Microstructure examination revealed that the sorbite structure forms in the hardened areas of series 4 and 10. Therefore the hardening treatment, after which the sorbite was formed in the surface, is the best for the parts, manufactured from the given steel and operating under cyclic load conditions.

Rolling samples of series 2 by rollers increase their fatigue strength. After rolling, the residual compression stresses are developed on the surface of the samples, whereas pearlite reduces [25]. However mechanical granulation of pearlite plates decreases fatigue strength of samples of series 2, in comparison to series 4 and 10.

Hardening of the samples with high-frequency electric current after rolling by rollers (series 3) significantly decrease their fatigue strength. This is related with the fact that surface resistance to the occurrence of fatigue cracks decreases [26].

Medium tempering (series 5 and 6) does not stimulate essential structural changes of the surface layer. Therefore fatigue strength of the samples of these series does not differ much from the samples of series 4.

Fatigue strength of the samples of series 9, for which a one hour tempering at 300 °C was employed in the final treatment stage, decreases due to tempering brittleness. Due to such tempering, brittleness increases in grain limits, which is revealed in fractographies of fatigue fracture. During the process of fatigue a lot of micro cracks occur in the samples of the series, which when binding develop a rather massive steps. Fatigue cracks are developed on the surface of the samples of the series. This reveals a low resistance of the hardened surface layer to the formation of micro cracks.

Comparing the series 8 and 10, it may be stated that

after treatment samples with regime 8, several nodus of micro cracks are formed under the hardened surface layer. This does not happen in the samples of series 10. In this case failure is always initiated in one hotbed of micro crack.

Distribution of micro hardness of investigated samples in the hardened layer and their size is tightly related with the structure of the hardened layer. It defines changes of mechanical properties of the hardened layer and determines fatigue strength of the given material.

The character of fatigue failure of the analysed samples depends on the micro hardness of their surface. Failure of the samples, micro hardness of which exceeded 700 H_{100} , begins in the internal areas of the sample, in the limit, which separates the hardened surface from the internal one. In this case, an ellipse zone is formed, which in literature is called "a fish eye" [27–30]. Micro hardness of the samples, which decomposed due to micro cracks, which occurred on the surface, did not exceed 450 H_{100} .

Analyzing change of micro hardness in the depth of hardened layer and comparing it with the fatigue strength, dependence is observed between the parameters of the hardened layer and the fatigue limit of corresponding samples.

Dependence of fatigue limit of the unhardened layer and unhardened core parameters (Fig. 4) is given by:

$$\sigma_w = f\left(\frac{H_w^p}{H_w^v} \cdot \frac{h}{R}\right), \quad (1)$$

where H_w^p is the value of micro hardness on the sample surface (H_{100}), H_w^v is the value of micro hardness in the unhardened core (H_{100}), h is hardened layer depth (mm), R is the diameter of sample's gauge length (mm).

Data of this dependence enable to predict the fatigue strength of 7 mm–10 mm differently hardened samples

from the given steel according to the value of: $\frac{H_w^p}{H_w^v} \cdot \frac{h}{R}$.

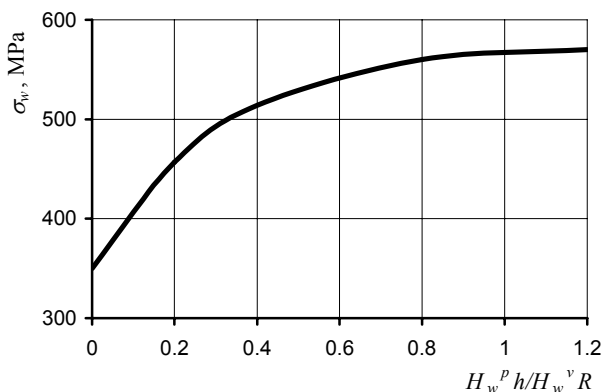

Fig. 4. Dependence of steel's fatigue strength on the parameters of hardened layer

Dependence of fatigue strength of samples of the tested series on the parameters of the hardened surface layer enable to predict a fatigue limit. However certain limitary conditions must be retained. The fatigue limit may be successfully predicted for the 7 mm–10 mm samples of the given steel, the hardened layer depth of which

$0.1 \text{ mm} < h < 2 \text{ mm}$ and the ratio of micro hardness of the hardened surface and unhardened core equals:

$$\frac{H_w^p}{H_w^v} \leq 4. \quad (2)$$

The formation of analogous curves for other materials would enable to simplify the selection of optimum hardening treatment.

The curve presented in Fig. 4 reveals that fatigue limit after hardening treatment increases to a certain degree. In

our case σ_w , when $\frac{H_w^p}{H_w^v} \cdot \frac{h}{R} = 1$, asymptotically reaches

570 MPa. This value of fatigue limit is limitary for the given steel and technology of hardening, and it reveals the limit of their capacities.

4. CONCLUSIONS

1. Experimentally it is proved that thermal treatment of plastically deformed carbon steel significantly increases fatigue strength.
2. It is proved that hardening effect depends on the residual stresses introduced applying deformation (the hardening depth) and thermal treatment regimes. The optimal treatment of the analysed carbon steel is deformation up to 1 mm depth, hardening with high-frequency electric current and tempering for 2 hours at 200 °C.
3. The dependence of fatigue limit on the distribution of micro hardness on the hardened surface layer and unhardened core is determined.

REFERENCES

1. Vilyš, J., Čiuplys, V., Terentjev, V., Kolmakov, A., Kvedaras, V. Particularities of Plastic Deformation of Metals Near Surface Layer. Kaunas, Technologija, 2003: 207 p.
2. Terentjev, V. F. Fatigue of Metallic Materials. Moscow, Nauka, 2002: 248 p. (in Russian).
3. Akiniwa, Y., Stanzl-Tschegg, S., Mayer, H., Wakita, M., Tanaka, K. Fatigue Strength of Spring Steel Under Axial and Torsional Loading in the Very High Cycle Regime *International Journal of Fatigue* 30 2008: pp. 2057–2063.
4. Nascimento, M. P., Souza, R.C., Pigatin, W. L., Voorwald, H. J. C. Effects of Surface Treatments on the Fatigue Strength of AISI 4340 Aeronautical Steel *International Journal of Fatigue* 23 2001: pp. 607–618.
5. Ceshcini, L., Minak, G. Fatigue Behavior of Low Temperature Carburised AISI 316L Austenitic Stainless Steel *Surface Coatings Technology* 202 2008: pp. 1778–1784.
6. Limodin N., Verreman Y. Fatigue Strength Improvement of a 4140 Steel by Gas Nitriding: Influence of Notch Severity *Materials Science and Engineering A* 435 2006: pp. 460–467.
7. Shulov, V. A., Nochovnaya, N. A. Fatigue Strength of Metals and Alloys Modified by Ion Beams *Surface Coatings Technology* 158–159 2002: pp. 33–41.
8. Kunz, L., Lukáš, P., Konečná, R. Fatigue Properties of Superalloy IN 713LC and Relation to Microstructure *Materials Science (Medžiagotyra)* 14 (3) 2008: 221–225.

9. **De la Cruz, P., Oden, M., Ericson, T.** Effect of Laser Hardening on the Fatigue Strength and Fracture of a B-Mn Steel *International Journal of Fatigue* 20 (5) 1998: pp. 389–398.
10. **Nishida, S.-I., Zhou, C., Hattori, N., Wang, Sh.** Fatigue Strength Improvement of Notched Structural Steels with Work Hardening *Materials Science and Engineering A* 468–470 2007: pp. 176–183.
11. **Pariente, I. F., Guagliano, M.** About the Role of Residual Stresses and Surface Work Hardening on Fatigue ΔK_{th} of a Nitrided and Shot Peened Low-Alloy Steel *Surface & Coatings Technology* 202 2008: pp. 3072–3080.
12. **Dai, K., Shaw, L.** Analysis of Fatigue Resistance Improvements via Surface Severe Plastic Deformation *International Journal of Fatigue* 30 2008: pp. 1398–1408.
13. **Topic, M., Allen, C., Tait, R.** The Effect of Cold Work and Heat Treatment on the Fatigue Behaviour of 3CR12 Corrosion Resistant Steel Wire *International Journal of Fatigue* 29 2007: pp. 49–56.
14. **Tian, J. W., Shaw, L., Liaw, P. K., Dai, K.** On the Ductility of a Surface Severely Plastically Deformed Nickel Alloy *Materials Science and Engineering A* 498 2008: pp. 216–224.
15. **Nalla, R. K., Altenberger, I., Noster, U., Liu, G. Y., Scholtes, B., Ritchie, R. O.** On the Influence of Mechanical Surface Treatments – Deep Rolling and Laser Shock Peening – on the Fatigue Behavior of Ti-6Al-4V at Ambient and Elevated Temperatures *Materials Science and Engineering A* 355 2003: pp. 216–230.
16. **Vilys, J., Tamulevičius, S., Grigaliūnas, V., Meškinis, Š., Guobienė, A.** Surface Engineering and Nanotechnologies. Kaunas, Technologija, 2007: 226 p. (in Lithuanian).
17. **Vetter, J., Barbezat, G., Crummenauer, J., Avissar, J.** Surface Treatment Selections for Automotive Applications *Surface and Coatings Technology* 200 2005: pp. 1962–1968.
18. **Dong, C., Wu, A., Hao, S., Zou, J., Liu, Z., Zhong, P., Zhang, A., Xu, T., Chen, J., Xu, J., Liu, Q., Zhou, Z.** Surface Treatment by High Current Pulsed Electron Beam *Surface and Coatings Technology* 163–164 2003: pp. 620–624.
19. **Wagner, L.** Mechanical Surface Treatments on Titanium, Aluminum and Magnesium Alloys *Materials Science and Engineering A* 263 1999: pp. 210–216.
20. **Sule Yildiz Sirin, Kahraman Sirin, Erdinc Kaluc.** Effect of the Ion Nitriding Surface Hardening Process on Fatigue Behavior of AISI 4340 Steel *Materials Characterization* 59 2008: pp. 351–358.
21. **Rudnev, V., Loveless, D., Cook, R., Black, M.** Handbook of Induction Heating. Marcel Dekker, Inc., New York, 2003: 777 p.
22. **Augutis, V., Ramanauskas, R., Čiuplys, A., Vilys, J., Čiuplys, V.** Determination of Metal Surface Hardened Layer Depth Using Magnetic Barkhausen Noise *Materials Science (Medžiagotyra)* 12 (1) 2006: pp. 84–87.
23. **Stephens R. A., Fatemi, A., Stephens, R. R., Fuchs, H. O.** Metal Fatigue in Engineering. (2nd Edition), New York, Wiley-IEEE, 2001: 496 p.
24. **Furuya, Y., Matsuoka, S.** Gigacycle Fatigue Properties of a Modified-Ausformed Si-Mn Steel and Effects of Microstructure *Metallurgical and Materials Transactions A* 35 2004: pp. 1715–1723.
25. **Cretu, S., Benchea, M., Cretu, O.** Compressive Residual Stresses Effect on Fatigue Life of Rolling Bearings *Proceedings of the ASME International Mechanical Engineering Congress and Exposition 2007, Vol. 3 – Design and Manufacturing* 2008: 485–490.
26. **Murakami, R., Yonekura, D., Ni, Z.** Fatigue Fracture Behavior of High-Strength Steel in Super Long Life Range *JSME International Journal Series A – Solid Mechanics and Material Engineering* 45 (4) 2002: pp. 517–522.
27. **Nakajima, M., Sakai, T., Shimizu, T.** An Observation of Fish-Eye Fracture Process in High Strength Steel SUJ2 *Journal of the Japan Society of Mechanical Engineers* 65 A 1999: pp. 2504–2513.
28. **Marines, G. I., Paris, P. C., Tada, H., Bathias, C., Lados, D.** Fatigue Crack Growth from Small to Large Cracks on Very High Cycle Fatigue with Fish-Eye Failures *Engineering Fracture Mechanics* 75 (6) 2008: pp. 1657–1665.
29. **Shiozawa, K., Morii, Y., Nishino, S., Lu, L.** Subsurface Crack Initiation and Propagation Mechanism in High-Strength Steel in a Very High Cycle Fatigue Regime *International Journal of Fatigue* 28 2006: pp. 1521–1532.
30. **Sohar, Ch. R., Betzwar-Kotas, A., Gierl, Ch., Weiss, B., Danninger, H.** Fractographic Evaluation of Gigacycle Fatigue Crack Nucleation and Propagation of a High Cr Alloyed Cold Work Tool Steel *International Journal of Fatigue* 30 2008: pp. 2191–2199.