

The Influence of Wood Structure Destruction on Viscous Elastic Properties

Jonas VOBOLIS, Darius ALBREKTAS*

Faculty of Design and Technologies, Kaunas University of Technology, Studentu 56, LT-3031, Kaunas, Lithuania

Received 21 May 2008; accepted 29 September 2008

The paper presents methods and equipment of resonance vibrations used in the studies of influence of wood assortments destruction. The analysis of macrostructure of spruce wood boards and from their cute scantlings is presented. It is shown that modulus of elasticity and coefficient of damping of scantlings depends on orientation of boards cut and proportion of early wood and late wood in the nick. It is obtained that the modulus of elasticity of scantlings in case of radial and mixed cut is by 5 % less than the modulus of elasticity of boards whereof scantlings are cutaway. In case of tangential cut destruction of boards, practically no influence was found. In all cases coefficient of damping of scantlings was higher by 40 % than that for boards. Modulus of elasticity of boards is higher by 2.5 % and coefficient of damping – by 10 % less than the average parameters of from their cute scantlings. The data of research can be used in the making of acoustical and glued-up article of wood, on the selection of viscous elastic parameters of separate parts.

Keywords: scantling, board, modulus of elasticity, coefficient of damping, resonance vibration, spruce wood, early wood, late wood.

1. INTRODUCTION

When producing wooden articles and selecting wood it is necessary to know mechanical properties not only of the product but also of its separate parts.

Wood is attributed to viscous elastic materials. Therefore classical research methods with evaluation of modulus of elasticity and viscous characteristics do not provide good results [1, 2]. With dynamic research in wooden samples, oscillation frequency allows to evaluate modulus of elasticity, and the dissipation of energy – coefficient of damping [3, 4].

Individual parts of a wooden article are made of various parts of a tree trunk. In many cases it is necessary to know the regularities of distribution of viscous elastic properties throughout the trunk of a tree. Much of work was done to evaluate the properties of a tree trunk as well as the distribution of viscous elastic properties over the trunk [5–7].

Wood is widely used as a building material. The columns, beams, floor and various revetments, etc., are made of it. Both natural and glued-up wood is used for this. When deciding of strength properties of wooden constructions, it is of high importance to take into account a dynamic modulus of elasticity. For sound insulation the main wood parameters are mass or density, critical frequency and coefficient of damping [8].

Recently a glued-up wood became widely used, the properties of which are determined by the properties of separate components [9]. It is known that modulus of elasticity of glued-up board is higher, and coefficient of damping is lower than analogous parameters of the used scantlings.

Producing the acoustic wooden articles, i. e., acoustic boards, furniture, floor, and others, it is necessary to ensure a required sound absorption coefficient. In most cases it is

determined not only by the type of wood, but also by the appropriate construction of the article [10, 11].

Many producers of musical instruments pay attention to rings of wood, ratio of early and late wood, density and other [8]. Much work was done to evaluate mechanical properties of resonant wood, and to determine the dependence between anatomic elements of wood and acoustic properties [12].

In the analysis of wood structure from the trunk to the roots, it is known that early wood is made of thin-walled and wide-cavity elements, and the late one – of thick-walled elements (Fig. 1) [13, 14]. It is obvious that in wood processing from balks to planks, and various elements and samples, the structure of particular part is destroyed.

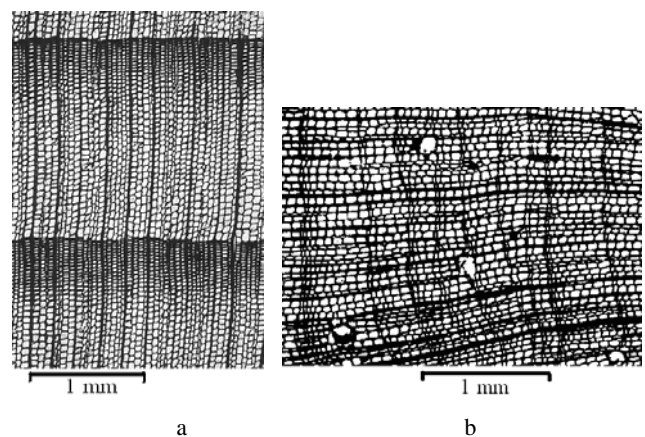

Fig. 1. Cuts of a fir (a) and pine (b) wood: a – crosscut of trunk; b – crosscut of root [13, 14]

Elimination of one component (e. g. cutting off the part of early or late wood of a ring) will have some influence on viscous elastic properties of the product.

The objective of this study – to evaluate the effect of structure integrity on viscous elastic properties of wood.

*Corresponding author. Tel.: +370-37-300230; fax.: +370-37-353863.
E-mail address: darius.albrektas@ktu.lt (D. Albrektas)

2. EXPERIMENTAL

In the research: 20 fir boards with dimensions (620×125×12) mm were used. The moisture varied between 9 % – 11 %, and density in the range of (405 – 525) kg/m³. Before the tests they were left in the premise for 2 months at the temperature about 20 °C, and relative air humidity about 60 %. The boards were cut out from various places of a balk. They did not have any visible imperfections and defects. The dimensions of the boards were measured by a sliding calliper (length with a precision of 0.05 mm, width and thickness with a precision of 0.02 mm), and mass was measured by the electronic scales (to within 0.01 g).

For the research an original method and equipment were applied [15]. The schemes of a test stand and studied assortment are presented in Figure 2.

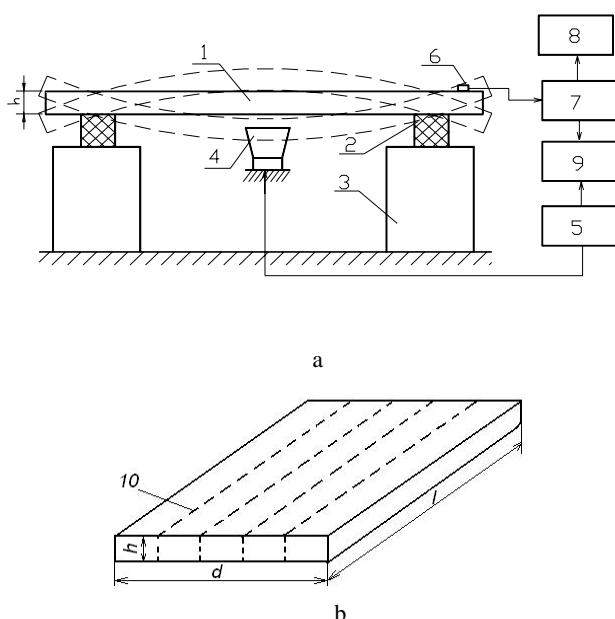

Fig. 2. Schemes of a test stand for wood articles (a) and of board (b): 1 – wood assortment and type of its inflection (mode); 2 – elastic elements; 3 – massive support; 4 – acoustic vibrator; 5 – generator; 6 – vibrosensor; 7 – gauge; 8 – oscilloscope; 9 – phasometer; 10 – location of a rip; l – length of a board, d – width, h – thickness

Since an assortment is freely placed on elastic elements 2, this case satisfies the boundary conditions of unattached board or side of a bar [16].

Having determined the frequency at which the oscillating studied assortment bends in a first mode and after evaluation of other parameters, modulus of elasticity is calculated [17].

$$E = \frac{4f_r^2 \pi^2 l^4 \rho s}{A^2 I}, \quad (1)$$

where f_r is a resonant frequency of the first mode; l is the length of sample; ρ is the density; s is the area of a cross-section; A is the coefficient depending on the type of sample attachment and inflection mode; I is the moment of cross-section inertia.

It is known that mentioned method and equipment allow measuring the modulus of elasticity with precision by 0.5 % [7] (resonance frequency of wood articles were measured with a precision of 0.1 Hz, length of board (scantling) – with a precision of 0.05 mm, width and thickness – 0.02 mm, mass – 0,01 g). Absolute instrumental error of modulus of elasticity was 40 MPa – 65 MPa.

After evaluation of the amplitude-frequency characteristic, the coefficient of damping of assortment is determined (loss angle tangent):

$$\operatorname{tg} \delta = \frac{f_2 - f_1}{f_r}, \quad (2)$$

where f_r is the resonant frequency, f_1, f_2 are the frequencies at which resonant amplitude decreases by $\sqrt{2}$ times.

Experimental error values of coefficient of damping were by 0.3 % (absolute instrumental error $(4 - 10) \times 10^{-5}$ r. u.).

Later the boards were cut into 5 scantlings (width of a rip about 1.5 mm) of the same width (about 23 mm), and modulus of elasticity and coefficient of damping of integral board were compared with the average parameters of the scantlings composing it. In order to prevent the variation in mechanical properties due to environmental effects, tests of each board were performed within 2 hours. Research was carried out in the following order. At first modulus of elasticity and coefficient of damping of the board were estimated. Then a first scantling was cut off it, and parameters of a cut out scantling and narrowed board were determined. Analogically the second, the third, and the fourth scantlings were cut off evaluating modulus of elasticity and coefficient of damping of them and of „remained“ board.

3. EXPERIMENTAL RESULTS AND DISCUSSION

According to the dominant arrangement of fibre, the boards were classified into three groups. The first group included the boards with the dominating radial cut (10 boards). Their average density was 474 kg/m³. The second group – tangential cut (4 boards, 428 kg/m³), the third – combined cut (6 boards, 449 kg/m³).

The variation of average modulus of elasticity and coefficient of damping of the first group boards and of scantlings forming the boards are presented in Figure 3 (each point shows the average value of 10 specimens).

One can see (Fig. 3) that modulus of elasticity of not destroyed boards is about 3 % higher (it varied in the range of 9850 MPa – 10000 MPa) than the average modulus of elasticity of scantlings (varied between 9610 MPa – 9720 MPa). The coefficient of damping in this case is about 10 % lower. It was determined that coefficient of damping of the boards has varied in the range of (0.0097 – 0.0111) r. u., and of scantlings – (0.0115 – 0.0120) r. u. Analysing individual boards of the first group, it was established that in some cases the modulus of elasticity was up to 5 % higher and the damping coefficient up to 40 % lower than respective parameters of the scantlings forming it. Density of late wood is by 2 times higher than density of early wood and modulus of elasticity is directly proportional for density [18, 19].

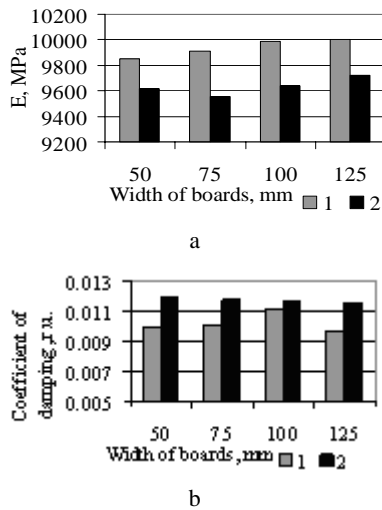

Fig. 3. Variation of modulus of elasticity (a) and coefficient of damping (b) of the boards with radial cut and scantlings forming them: 1 – parameters of uncut boards; 2 – average parameters of scantlings forming some parts of boards

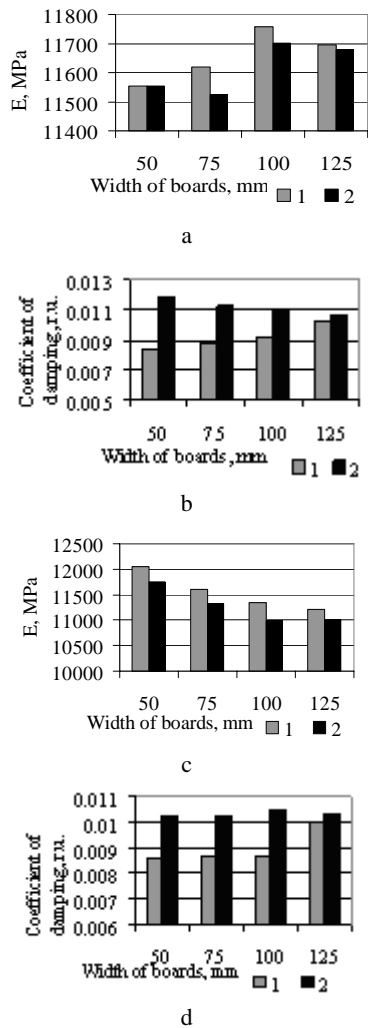

Fig. 4. Variation of modulus of elasticity and coefficient of damping of the boards with tangential cut (a, b) and combined (c, d) cut and their scantlings; where 1 – parameters of uncut board; 2 – average parameters of scantlings forming a respective part of a sample

The boards of the second and third group were analysed analogically. Variation of modulus of elasticity and coefficient of damping of the boards and their scantlings are shown in Fig. 4.

One can see (Fig. 4) that modulus of elasticity in the case of boards with tangential cut and scantlings forming them are very close (difference was around 0.2 % on average). The modulus of elasticity of the boards varied in the range of 11550 MPa–11760 MPa, and of cut off scantlings – 11520 MPa–11920 MPa. In the case of combined cut the modulus of elasticity of the boards was about 2 % higher (of boards 11210 MPa–12040 MPa, and of scantlings – 11000 MPa–11750 MPa).

The coefficient of damping in this case was also around 10 % lower (mean coefficient of damping of the boards varied between 0.0084 r.u.–0.0103 r.u., and of scantlings – between 0.0102 r.u.–0.0107 r.u.). It was determined that in some cases coefficient of damping has decreased to 32 %.

Determined values of the modulus of elasticity and coefficient of damping of boards were coherent with the density of boards (absolute instrumental error of density was 2.5 kg/m^3). Regularities of variation of density, modulus of elasticity and coefficient of damping of the first group boards (10 boards) with radial cut are presented in Fig. 5.

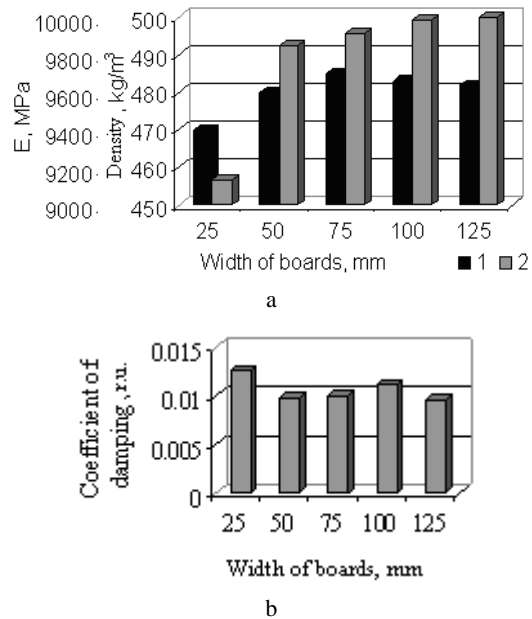

Fig. 5. Variation regularities of average density (a, 1), modulus of elasticity (a, 2) and coefficient of damping (b) of the boards with radial cut

It was established (Fig. 5) that, when density of boards changes in the range of 470 kg/m^3 – 485 kg/m^3 , the range of modulus of elasticity variation was 9400 MPa–10000 MPa, and of coefficient of damping – 0.0126 r.u. – 0.0097 r.u. Analogical regularities were obtained also in the case of boards of other groups. It was determined that in the case of tangential cut, when the average density of the boards increases from 415 kg/m^3 to 440 kg/m^3 , the modulus of elasticity increased from 11550 MPa to 11820 MPa, and the coefficient of damping decreased from 0.0103 r.u. to 0.0083 r.u. With a density of the boards

with combined cut changing from 450 kg/m³ to 466 kg/m³, the modulus of elasticity increased from 11210 MPa to 12045 MPa, and the coefficient of damping – from 0.0087 r. u. to 0.0100 r. u.

To evaluate more correctly the influence of the board integrity destruction, the macrostructure of wood was estimated. It was determined that in the boards with radial and combined cut the number of rings varied from 26 to 51, and their width was 2 mm–5 mm. The ratio of early and late wood in these boards was various: in some (6 boards) it was practically equal, and in other (7 boards) early wood exceeded late about 3 times. It is obvious that the density of wood depended on this ratio. Average density of the boards with nearly the same amount of late wood as early one, was 497 kg/m³, and of the boards with prevailing early wood – 440 kg/m³.

Besides it was determined that the difference of viscous elastic properties of boards and their scantlings depended on dominating type of wood in the rip. All rips were classified into three groups: A – early wood prevailing in the rip, B – nearly the same amount of early and late wood in the rip, C – late wood prevailing in the rip. Thus values of differences of modulus of elasticity and coefficient of damping of boards and scantlings forming boards were evaluated. Data of the research are shown on Fig. 6.

As we may see (Fig. 6) cutting through the early wood the modulus of elasticity of the boards is about 1.2 % higher than the average modulus of elasticity of scantlings forming them. When nearly the same amount of early and late wood was in the rip, this difference increased up to 2.5 %. If in the rip late wood dominate, modulus of elasticity of boards was about 5 % higher than average modulus of elasticity of scantlings forming them. It was determined that the coefficient of damping in this case is distributed according to other regularities. It was established that the coefficient of damping changes at most when nearly the same amount of early and late wood come into the rip (in this case coefficient of damping of the boards is about 31 % lower than modulus of elasticity of

scantlings forming them). When cutting through early or late wood the coefficient of damping of the boards decreases respectively 17 % and 21 %.

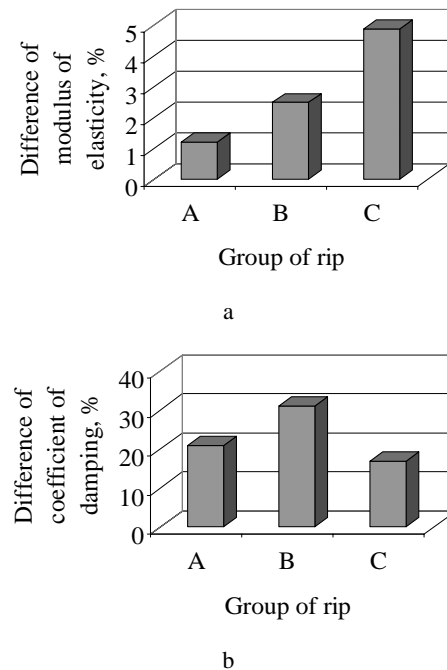

Fig. 6. Values of average differences of modulus of elasticity (a) and coefficient of damping (b) of the boards with radial and combined cuts and their scantlings

As it is known (Fig. 1), the diameter of tracheides of early wood is much bigger, and the walls are thinner than of late wood tracheides. Also the late wood is much stiffer, and its modulus of elasticity is much higher than of early wood. On the other hand, it is known that elastic and viscous properties of viscous elastic body (including wood) in the assortment are distributed in inverse ratio [7].

The values of modulus of elasticity of first group boards and scantlings forming them are shown in Table 1.

Table 1. Modulus of elasticity of the first group boards and scantlings forming them

Number of board	Modulus of elasticity of boards, MPa	Modulus of elasticity of scantlings, MPa					$\frac{\sum_{i=1}^5 E_i}{5}$	ΔE , MPa	ΔE , %
		E_1	E_2	E_3	E_4	E_5			
1	10180	10900	10070	9210	9470	8620	9654	526	5.2
2	11180	11050	12700	12620	8520	10580	11094	86	0.8
3	12550	13750	12970	13940	11870	7960	12098	452	3.6
4	8920	8620	9510	8130	8740	7870	8574	346	3.9
5	10010	9550	9220	9040	11010	10370	9838	172	1.7
6	8610	7990	8540	7830	8060	7770	8038	572	6.6
7	8920	8620	9960	8170	8480	7540	8554	366	4.1
8	10470	10450	9460	10500	10530	10660	10320	150	1.4
9	9600	10040	8470	7750	9850	10200	9262	338	3.5
10	10120	11200	9650	9270	9150	9790	9812	308	3.0
Average	10060						9724	332	3.3

* here E_i – modulus of elasticity every of scantlings, ΔE – difference between modulus of elasticity of boards and average modulus of elasticity of scantlings forming them.

Table 2. Coefficient of damping of the first group boards and scantlings forming them

Number of board	Coefficient of damping of boards, r.u.	Coefficient of damping of scantlings, r. u.					$\frac{\sum_{i=1}^V \text{tg}^i \delta}{5}$	$\Delta \text{tg} \delta$, r.u.	$\Delta \text{tg} \delta$, %
		$\text{tg}^I \delta$	$\text{tg}^{II} \delta$	$\text{tg}^{III} \delta$	$\text{tg}^{IV} \delta$	$\text{tg}^V \delta$			
1	0.0109	0.0089	0.0106	0.0110	0.0128	0.0176	0.0122	0.0013	11.9
2	0.0102	0.0144	0.0117	0.0099	0.0130	0.0127	0.0124	0.0021	20.8
3	0.0089	0.0094	0.0099	0.0104	0.0093	0.0145	0.0107	0.0017	19.4
4	0.0097	0.0119	0.0158	0.0123	0.0150	0.0127	0.0135	0.0039	39.8
5	0.0085	0.0089	0.0095	0.0126	0.0088	0.0114	0.0102	0.0018	20.8
6	0.0112	0.0129	0.0122	0.0089	0.0116	0.0116	0.0114	0.0002	1.9
7	0.0094	0.0109	0.0122	0.0127	0.0121	0.0155	0.0127	0.0033	34.5
8	0.0080	0.0095	0.0104	0.0106	0.0095	0.0100	0.0100	0.0020	25.7
9	0.0090	0.0108	0.0129	0.0118	0.0100	0.0086	0.0108	0.0018	20.5
10	0.0108	0.0116	0.0100	0.0114	0.0114	0.0106	0.0110	0.0002	1.5
Average	0.0097						0.0115	0.0018	18.9

* here $\text{tg}^i \delta$ – coefficient of damping every of scantlings, $\Delta \text{tg} \delta$ – difference between coefficient of damping of boards and average coefficient of damping of scantlings forming them.

As we can see in Table 1, in all cases modulus of elasticity of boards is higher than average modulus of elasticity of scantlings forming them. Difference varies in range 80 MPa–570 MPa (0.8 %–6.6 % in total value). The modulus of elasticity of assortments was measured with precision by 0.5 %.

The values of coefficient of damping of first group boards and scantlings forming them are shown in Table 2.

Obtained (Table 2), that in all cases coefficient of damping of boards is lower than average coefficient of damping of scantlings forming them. Difference was 1.5 %–40 % (coefficient of damping of assortments was measured with precision by 0.3 %).

Obtained values of difference of modulus of elasticity and coefficient of damping of boards and scantlings were processed statistically. Statistical data are shown in Table 3.

Table 3. Statistical rates of differences of modulus of elasticity and coefficient of damping of the first group boards and scantlings forming them

Statistical rate	Difference of modulus of elasticity	Difference of coefficient of damping
Average value	332	0.0018
Average square deflection	160	0.0012
Variation coefficient, %	48	63

As we can see in Table 3 the scatter of difference of viscous elastic properties of boards and forming them scantlings is enough big (variation coefficient of values of difference of modulus of elasticity is 48 % and coefficient of damping – 63 %).

Analogical results were obtained also in the case of boards of others group.

It is obvious that changes in modulus of elasticity and coefficient of damping were due to destruction of integral structure of the board, and also in the sample with altered ratio of early and late wood.

Thus the research results allow evaluating the degree of wood structure destruction as well as of changes in the properties. It is clear that, for instance, when cutting the beam into the boards, the value of modulus of elasticity is „lost“, and the value of coefficient of damping is „gained“. Research results may be used in manufacture of acoustic and glued wood articles, in selection of appropriate parameters of separate parts, i.e., number, number of joints, etc.

4. CONCLUSIONS

1. It was determined that in the case of radial and combined cut, the modulus of elasticity of the boards is up to 2.5 % higher than average modulus of elasticity of scantlings cut out of them, and in the case of tangential cut, the modulus of elasticity are close (difference is about 0.2 %).
2. It was established that with an increase of late wood in the rip, the modulus of elasticity of the scantlings decreases by 5 % compared to the modulus of elasticity of the boards.
3. It was found that irrespective of the cut chosen, the coefficient of damping of the boards is up to 10 % lower than average coefficient of damping of the scantlings cut out of them.
4. It was set that, when boards were cut into scantlings, an average coefficient of damping of the scantlings may increase to 31 %.
5. It was determined that the modulus of elasticity of fir boards varies in direct ratio, and the coefficient of damping - in reverse ratio to density variation.

REFERENCES

1. **Kasal, B., Heudusche, A.** Radial Reinforcement of Curved Glue Laminated Wood Beams with Composite Materials *Forest Products Journal* 54 (1) 2004: pp. 74–79.
2. **Kasal, B.** Semi-Destructive Method for In-Situ Evaluation of Compressive Strength of Wood Structural Members *Forest Products Journal* 53 (11–12) 2003: pp. 55–58.
3. **Molin, N. E., Lindgren, L. E., Jansson, E. V.** Parameters of Violin Boards and their Influence on the Board Modes *Journal Acoustical Society America* 83 (1) 1988: pp.281–291.
4. **Cai, Z., Ross, R. J., Hunt, M. O., Soltis, L. A.** Plot Study to Examine Use of Transverse Vibration Nondestructive Evaluation for Assessing Floor Systems *Forest Products Journal* 52 (1) 2002: pp 89–93.
5. **Brüchert, F., Becker, G., Speck, T.** The Mechanics of Norway Spruce [*Picea abies* (L.) Karst]: Mechanical Properties of Standing Trees from Different Thinning Regimes *Forest Ecology and Management* 135 (1–3) 2000: pp. 45–62.
6. **Niklas, K. J.** Mechanical Properties of Black Locust (*Robinia pseudoacacia* L.) Wood. Size- and Age-dependent Variations in Sap- and Heartwood *Annals of Botany* 79 (3) 1997: pp. 265–272.
7. **Vobolis, J., Albrektas, D.** Comparison of Viscous Elastic Properties in Wood of Leaf and Coniferous Tree *Materials Science (Medžiagotyra)* 13 (2) 2007: pp 147–151.
8. **Bucur, V.** Acoustics of Wood. Springer Series in Wood Science. Printed in Germany, 2006: 393 p.
9. **Vobolis, J., Albrektas, D.** Analysis of Wood Peculiarities by Resonant Vibration Method *Baltic Forestry* 13 (1) 2007: pp.109–115.
10. **Bata, M.** Effects on Buildings of Vibrations Caused by Traffic *Building Science* 6 (4) 2003: pp. 221–246.
11. **Soda, S.** Role of Viscous Damping in Nonlinear Vibration of Buildings Exposed to Intense Ground Motion *Journal of Wind Engineering and Industrial Aerodynamics* 59 (2–3) 1996: pp. 247–264.
12. **Niedzielska, B.** Investigations on the Interaction of Anatomical Elements of Spruce and Its Acoustical Properties *Acta Agrarie Silvestris* 12: pp. 85–100.
13. **Rybincek, M., Gryc, V., Vavrcik, A.** Annual Ring Analysis of the Root System of Scots Pine *Wood Research ISSN 1336-4561* 52 (3) 2007: pp. 1–14.
14. **Wagenführ, R.** Holzatlas. Leipzig. Fachbuchverlag, 2000: 708 p.
15. **Albrektas, D., Vobolis, J.** Evaluation of Mechanical Parameters and Quality of Solid Wood Panel by Vibration *Proceedings of the 5th International Conference Vibroengineering-2004*: pp. 49–54.
16. **Timoshenko, S., Young, D. H., Weaver, W. jr.** Vibration Problems in Engineering. Moscow. Mashinostroenie, 1985: 472 p.
17. **Tse, F. S.** Mechanical Vibrations. Boston. Allyn and Baon, Inc., 1963: 507 p.
18. **Barnett, J. R., Jaronimidis, G.** Wood Quality and Its Biological Basis. Victoria, Australia. Blackwell Publishing Ltd., 2003: 226 p.
19. **Desch, H. E., Dinwoodie, J. M.** Timber Structure, Properties, Conversion and Use. Great Britain, Chippenham and Fastbourne. Antony Rowe Ltd., Seventh Edition, 2002: 187 p.

Presented at the 17th International Conference "Materials Engineering'2008" (Kaunas, Lithuania, November 06–07, 2008)

DOI: 10.5755/j02.ms.26121