

Formation of Tungsten Carbide Coatings with Different Thermal Spray Guns

Artūras BABILIUS*, Kazys BABILIUS

Department of Manufacturing Technologies, Kaunas University of Technology, Kęstučio 27, LT-44025 Kaunas, Lithuania

Received 08 April 2008; accepted 30 April 2009

WC-12%Co powder of 53 μm –63 μm particle size were thermally sprayed by using high velocity oxygen fuel gun (HVOF) MicroJet and modified gas flame gun TopJet/2. Gas ratio during the spraying time was systematically varied to define influence of spraying parameters on the quality of coatings. Adhesive strength test were carried out by pull-off the pin method using an original device. Surface morphology investigation of the WC-12%Co coatings, sprayed by the MicroJet gun and modified gas flame gun TopJet/2, showed that the increase of the fuel gas flow rate resulted in reduction of the surface roughness and porosity as well as improved sintering of the particles. Adhesive strength of the coatings sprayed by the MicroJet gun varies from 46.5 MPa to 59.7 MPa. Fuel gas flow rate increase resulted to sudden increase of the adhesive strength. The adhesive strength of coating sprayed by modified TopJet/2 gun was smaller.

Keywords: powder, thermally sprayed, coating, adhesive strength, surface morphology.

1. INTRODUCTION

Various surface treatment technologies are used aiming to strengthen machine parts or to obtain other necessary properties. Surface properties can be changed by thermo-chemical treatment, surface hardening, laser alloying, overlaying welding, as well as coating by physical or chemical evaporation or thermal spraying. Coatings mostly are sprayed aiming to improve wear, corrosion or oxidation resistance of a part. Spraying of the protective coatings enable to change materials surface microstructure, chemical composition, morphology, hardness, etc.

One of the most important and widely spread surface strengthening methods is thermal spraying. It was developed and applied for the first time by Shoop in 1910 in Switzerland [1]. Shoop designed the gun, which was used for metals (Aluminum, Zinc) spraying in the hot air stream. Thermal spraying enables to produce coatings of various composition and purposes. Very often it is used for materials wear resistance improvement because it is simple and feasible surface strengthening method [1].

Application of thermal spraying for parts and tools surface strengthening or recovery enables to improve their endurance and lifetime, and to decrease operation costs.

Hard, wear resistant WC-Co coatings have wide application. They are highly resistant to erosion, adhesion and abrasive wear. Due to their features they are used in metallurgy, oil, power, transport, aviation and other industries [2–5].

Depending on the purpose of a coating and its operation conditions, different requirements to mechanical characteristics, composition, thickness, density and adhesion of a coating are established. Therefore, it is important to investigate effect of technological spraying parameters on the coating properties, predetermining reliability and durability of the targeted equipment.

Adhesion is one of the most important factors determining coating application, durability and also

exploitation properties. The adhesion of coating depends on spraying system, spraying parameters, material, residual stresses in coating, roughness of substrate. If adhesion of a coating is not sufficient, during the exploitation time coating may pull out, therefore occurs failure in mechanism. It is important that sprayed coating should be hard, resistant to wear or corrosive environment [6–8].

Measurements of the adhesive strength are normally conducted using the direct pull test as defined in the ASTM D4541 and ASTM C633-79 [9]. In these tests coating is applied to the end of a cylindrical rod (substrate) and another rod of the same material as the substrate is bonded to the top surface of the coating using a polymeric adhesive. When the adhesive strength of the coating/substrate interface is stronger than the strength of the polymeric adhesive, failure often occurs at the location of the adhesive and as a result the adhesion of the coating cannot be quantified [10, 11].

In addition to the direct pull test, many other tests for measuring the adhesive strength under engineering environments have been devised. Some examples of these tests are laser spallation tests, ultracentrifugal tests, peel tests, hammering tests and scratch tests [1, 12].

The objective of the research is to study properties of WC-12%Co coating, obtained in different thermal spraying methods. To achieve this objective, the following tasks have been solved:

- To investigate influence of technological spraying parameters on coating adhesive strength and surface morphology;
- To compare properties of WC-12%Co coatings sprayed by standard MicroJet and modified TopJet/2 guns.

2. EXPERIMENTAL TECHNIQUE

WC-12%Co powder (Fig. 1) of 53 μm –63 μm particle size were thermally sprayed by using a high velocity oxygen fuel gun (HVOF) MicroJet and modified gas flame gun TopJet/2 on the prepared by blasting specimens made of grade 45 structural steel. Blasting was carried out using Al_2O_3 grit of size 0.5 mm \div 1.0 mm.

*Corresponding author. Tel.: +370-687-48719, fax.: +370-37-323769.
E-mail address: arturasbabilius@gmail.com (A. Babilius)

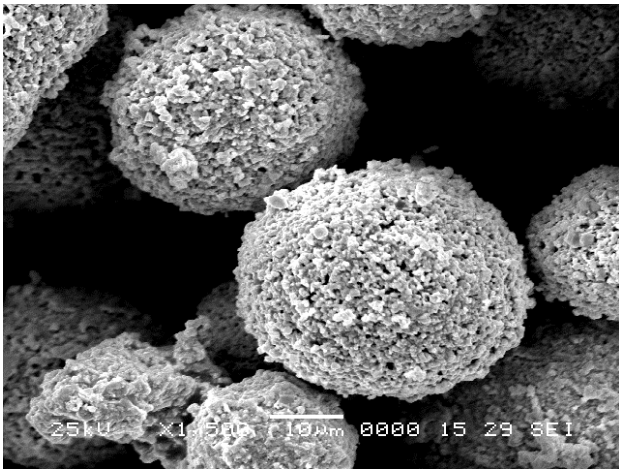

Fig. 1. Microstructure of WC-12%Co powder

During the spraying gas pressure was constant. Fuel gas (propane) pressure was 0.45 MPa, oxygen – 0.65 MPa, air – 6.5 MPa and transportation gas (nitrogen) 0.25 MPa. Gas ratio during the spraying was varied to study influence of spraying parameters on the properties of coatings (Tables 1, 2).

Table 1. Technological parameters of WC-12%Co coating sprayed by MicroJet gun

C ₃ H ₈ , l/min.	O ₂ , l/min.	N ₂ , l/min.	Powder, g/min.	Distance, mm	T, °C
22.5	51	10	35	160	93
22.5	142.6	10	35	160	115
25.6	142.6	10	35	160	131
29.5	142.6	10	35	160	138
33.3	142.6	10	35	160	142
36.4	142.6	10	35	160	146

Table 2. Technological parameters of WC-12%Co coating sprayed by TopJet/2 gun

C ₃ H ₈ , l/min.	O ₂ , l/min.	N ₂ , l/min.	Powder, g/min.	Distance, mm	T, °C
14.45	131	10	35	160	95
21.00	131	10	35	160	107
21.70	131	10	35	160	121
27.40	131	10	35	160	136
31.60	131	10	35	160	147

Adhesive strength test were carried out by pull off the pin method using device developed by the author. The principal scheme of device is shown in Figure 2.

To prepare specimens to the coating deposition, the conical pin 4 was put into the disc 5 and fixed by the screw 10. To make sure that the back of a pin and disc are in one plane, the assembled specimens surface were grinded. Then surfaces of the disc and pin were degreased, dried and subsequently grid blasted by using alumina grit to increase roughness of the surface. After fixing of the specimen into rotational device (Fig. 3, a) the WC-12%Co coating was sprayed (Fig. 3, b). For each experiment five specimens were coated at the same parameters to ensure statistical analysis. During the spraying, specimens were cooled by air. Temperature of the specimen didn't exceed

150 °C. The thickness of coating was 0.25 mm and it was measured with a portable coating thickness measurement instrument Fischer Dualscope MP20E-S equipped with magnetic induction test method according to DIN EN ISO 2178, ASTM B499 or BS 5411/11.

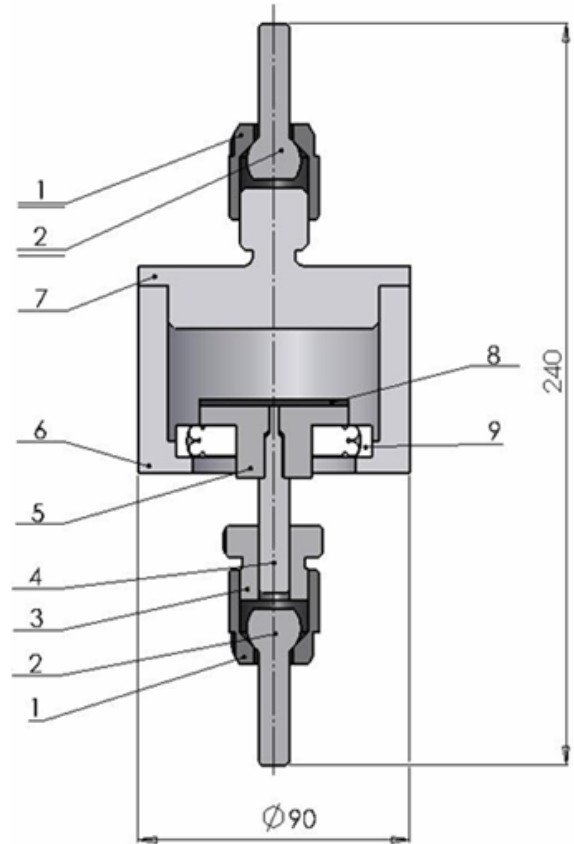

Fig. 2. The principal scheme of the adhesive strength device: 1 – nut; 2 – self-aligning screws; 3 – nut; 4 – conical pin; 5 – specimen's disc; 6 – hub; 7 – cap; 8 – coating; 9 – self-aligning bearing; 10 – fixing screw

Unscrewing the fixed screw 10, the specimen was mounted in a hub 6 on self-aligning bearing 9 (applied for eliminating of tangential force). After the screwing cap 7, the nuts 1 and 3, device together with the specimen was embedded into a tension testing machine where the tensile load was applied. By a pulling the specimens pin, system had some flexibility and force F_n was increased. After flexibility was removed, power eventually increased until the coating was separated from the substrate. It was measured the maximum normal tension force, by which coating was separated from the substrate. Bond strength of the coating was calculated using the ultimate force F , (when coating is separated) divided by the cross-section area of the specimen with a diameter d (Ø 3 mm):

$$\sigma = \frac{4F}{\pi \cdot d^2}, [\text{Pa}], \quad (1)$$

where F is the the ultimate force, N.

It is well known, that porosity and defects in the coating such as microcracks, insufficient or overheat of particles make strong influence to coating mechanical properties (such as bond strength, wear resistant in corrosive environment and etc.), therefore it is very

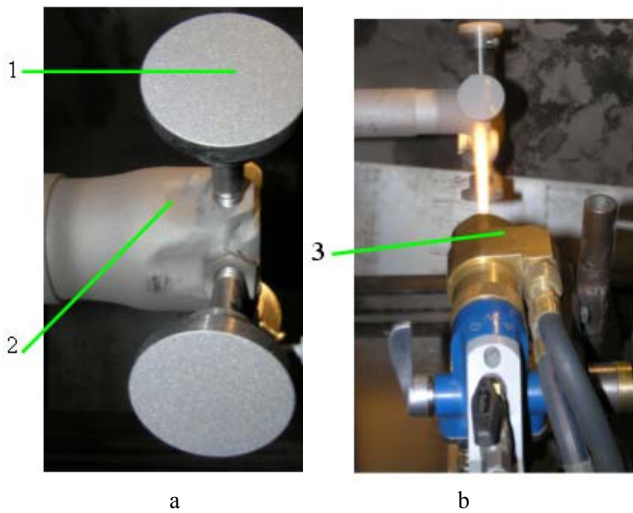

Fig. 3. Deposition of WC-12%Co coating on the specimens for determining adhesive strength: 1 – specimen; 2 – rotation device; 3 – spraying gun

important to perform morphology research of WC-12%Co coating trying to optimize the spraying parameters, determine the quality of coating surface.

Surface morphology of the coatings was investigated by a scanning electron microscope JSM 5600.

3. RESULTS AND DISCUSSIONS

Surface morphology investigation of the WC-12%Co coatings, sprayed by MicroJet gun, shows that in the coating there are not completely melted particles, when fuel gas was supplied at 22.5 l/min flow rate, and oxygen – at 51 l/min flow rate. The coating obtained had higher surface roughness, higher porosity (Fig. 5, a) and smaller cohesion between the particles. When oxygen flow rate was increased to 142.6 l/min, the particles in the coating surface had better sintered each to other but some not completely melted particles were formed as well (Fig. 5, b, b' and c, c').

Increase of the fuel gas flow rate resulted in reduction of the surface roughness and porosity and improved sintering of the particles. All particles were completely melted in the coating, sprayed at fuel gas flow rate 33.3 l/min (Fig. 5, d, d'); microstructure of the coating was fine, without defects. Increase of fuel gas flow rate to 36.4 l/min allowed to obtain even better melted coating (Fig. 5, e, e'), but the microstructure examination revealed the micro cracks, spread from the surface to the substrate in the cross – section of the coating (Fig. 4). It may be explained by the increased speed of particles at the impact with the substrate resulting large residual stress in the coating.

Tillmann has shown [13] that increase of oxygen flow during spraying lead to higher energy of HVOF jet and higher powder particle speed at the same time. That resulted to shorter dwell time of the particles in the jet, less porosity and also less oxidation. Our results confirmed that correct stoichiometry composition of gas during spraying was one of the most important factors to ensure good quality with minimum defects coating.

Coating surface morphology produced by TopJet/2 gun is presented in Figure 6. Supplying fuel gas at

14.45 l/min flow rate, great number of not melted and partially melted particles was found in the coating (Fig. 6, a, a'). Poorly sintered particles can be seen in the microstructure. In some cases, due to not sufficient plasticity particles, which embedded the substrate, have fractured, and poor particles sintering can be seen. Increase of fuel gas flow rate to 21 l/min facilitated better sintering of the particles, but some crushed and not completely melted particle centres survived (Fig. 6, b, b'). There are obvious coating damages in such places. In operation these surface areas would flake and produce wear products.

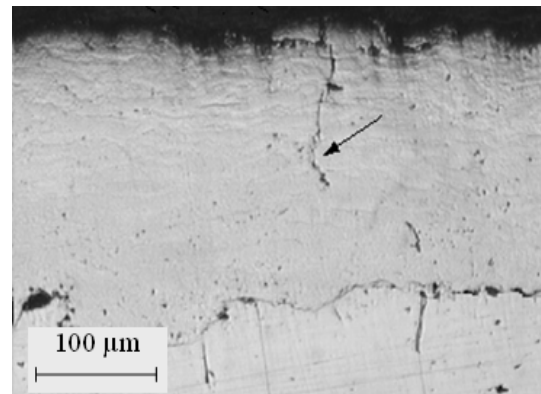

Fig. 4. Microstructure of the WC-12%Co coating sprayed by MicroJet gun at 36.4 l/min fuel gas supply rate

Partially not melted and broken particles, forming cracks in the coating are found as well (Fig. 6, c, c'). At increased to 27.4 l/min and 31.6 l/min fuel gas flow rate, not melted particles were not found in the coating, because gas stream makes them completely small, and they sinter well each to other (Fig. 6, d, d' and e, e').

Dependences of coatings adhesive strength (testing at normal tension stress) on gun type and gas flow rate are shown in Figs. 7 and 8. Adhesive strength of the coating sprayed by MicroJet gun varies from 46.5 MPa to 59.7 MPa (Fig. 7). At fuel gas supply rate 22.5 l/min and that of oxygen – 51 l/min, 46.5 MPa adhesive strength was obtained; oxygen flow rate increase to 131 l/min and that of fuel gas to 25.6 l/min, resulted negligible adhesive strength increase (to 49 MPa). Fuel gas flow rate increase to 33.3 l/min resulted sudden adhesive strength increase to 59.7 MPa.

The adhesive strength of coating sprayed by modified TopJet/2 gun is smaller (Fig. 8). Especially it is noticeable at small fuel gas flow rates. When fuel gas was supplied at 14.45 l/min and 21.0 l/min flow rates, the adhesive strength of the coating was 19.7 MPa only, i. e. two and a half times smaller than that of the coating sprayed by MicroJet gun. Increase of fuel gas flow rate to 21.7 l/min, 27.4 l/min and 31.6 l/min improved adhesive strength to 33.4 MPa, 39.3 MPa and 39.9 MPa correspondingly.

From the results described above and other's authors [14, 15] performed investigations about not melted particles, powder feed rate influence to coating adhesive strength it is possible to confirm that the gas jet speed, right powder feed rate, correct gas stoichiometric composition are the factors whose correct adjustment ensures maximal adhesive strength.

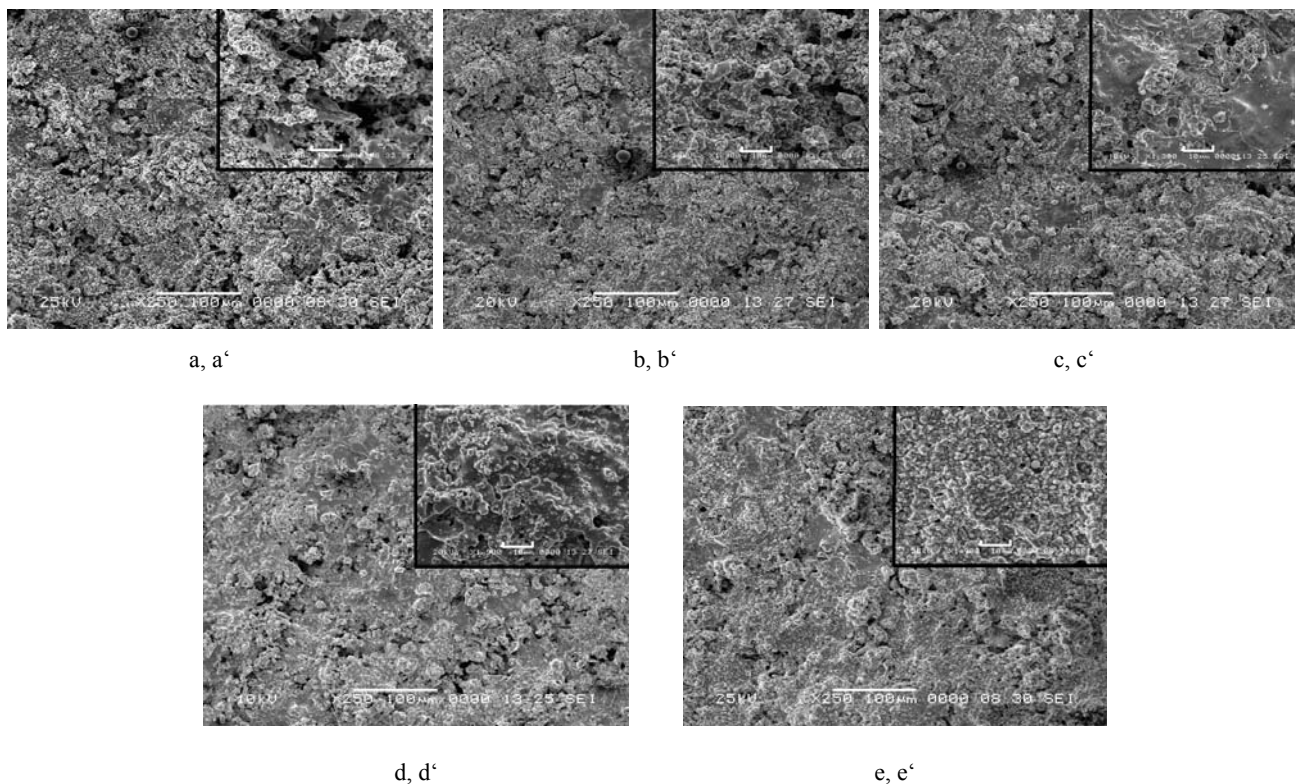

Fig. 5. Morphology of WC-12%Co coating sprayed by MicroJet gun at various gas (C_3H_8/O_2) flow rates, l/min: a, b – 22.5/51; c, d – 22.5/142.6; e, f – 29.5/142.6; g, h – 33.3/142.6; k, l – 36.4/142.6 (marks size on selected parts a'–e' – 10 μ m)

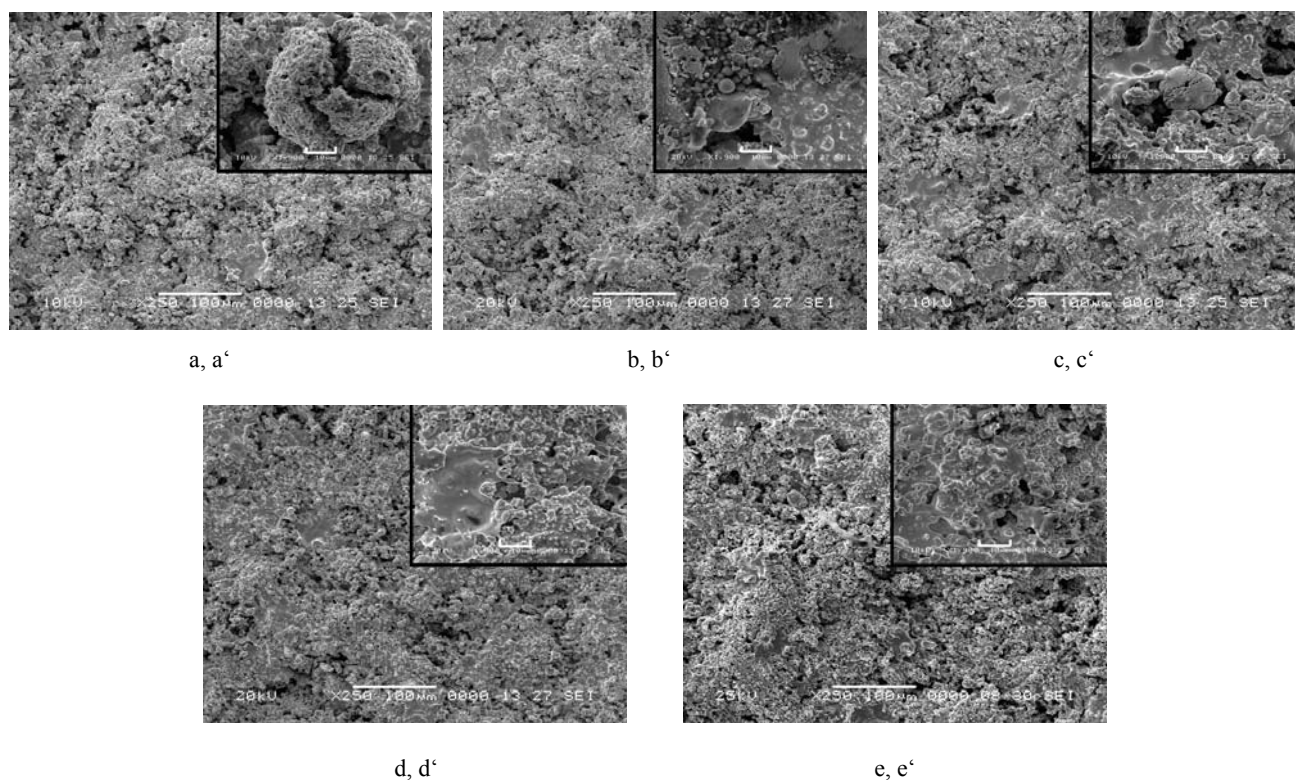

Fig. 6. Morphology of WC-12%Co coating sprayed by modified TopJet/2 gun at various gas (C_3H_8/O_2) flow rates, l/min: a, b – 14.45/131; c, d – 21/131; e, f – 21.7/131; g, h – 27.4/131; k, l – 31.6/131 (marks size on selected parts a'–e' – 10 μ m)

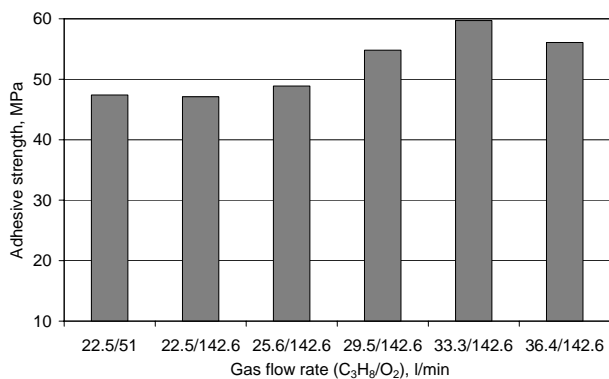

Fig. 7. Dependence of WC-12%Co coating, sprayed by MicroJet gun, adhesive strength on gas flow rate

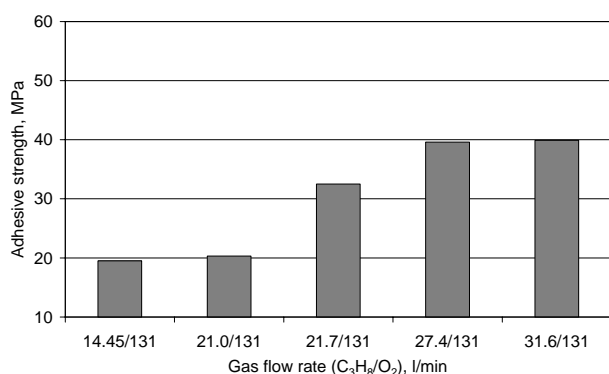

Fig. 8. Dependence of WC-12%Co coating, sprayed by modified TopJet/2 gun, adhesive strength on gas flow rate

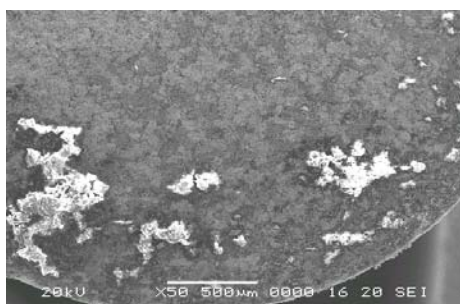

Fig. 9. The specimen's surface after coating was separated from substrate

In Figure 9 it is well visible surface of conical pin after performing adhesive strength test. Fact that coating is fully separated from the specimen's surface verify that there were measured adhesive but not cohesive strength, and the results are quite precise.

4. CONCLUSIONS

1. It was found that fuel gas output, changed by MicroJet, as well as by modified gas-flame gun TopJet/2, allows to obtain a coating with forecast properties. While spraying and increasing fuel gas output, coating porosity decreases as well as surface roughness, size of tungsten carbide crystallites, and adhesive strength of the coating increases, as well as microhardness and relative tungsten concentration in the coating.
2. After investigation of mechanical and physical properties of WC-12%Co coating sprayed by MicroJet and modified gas-flame TopJet/2 guns, thermal spraying

technology was offered and proved for obtaining of WC-12%Co coating with the best properties: the biggest adhesive strength and microhardness of the coating, minimal porosity, and not defective surface structure. Spraying with MicroJet gun, it is necessary to supply fuel gas in 33.3 l/min, and oxygen – in 142.7 l/min outputs, spraying with modified TopJet/2 gun – in 31.6 l/min and 131 l/min outputs, correspondingly. It is necessary to supply powder in constant, i. e. 35 g/min, output.

REFERENCES

1. **Davis, J. R.** Handbook of Thermal Spray Technology, USA, 2005: 338 p.
2. **Sudprasert, T., Shipway, P. H., McCartney, D. G.** Sliding Wear Behaviour of HVOF Sprayed WC-Co Coatings Deposited With Both Gas-Fuelled and Liquid-Fuelled Systems *Wear* 255 2003: pp. 943–949.
3. **Scrivani, A., Ianelli, S., Rossi, A., Groppetti, R., Casadei, F., Rizzi, G. A.** Contribution to the Surface Analysis and Characterisation of HVOF Coatings for Petrochemical Application *Wear* 250 2001: pp. 107–113.
4. **Schroeder, M., Unger, R.** Thermal Spray Coatings Replace Hard Chrome *Advanced Materials and Processes* 152 1997: pp. 19–21.
5. **Toma, D., Brandl, W., Marginean, G.** Wear and Corrosion Behaviour of Thermally Sprayed Cermet Coatings *Surface and Coatings Technology* 138 2001: pp. 149–158.
6. **Staia, M. H., Ramos, E., Roman, A., Lesage, J., Chicot, D., Mesmacque, G.** Effect of Substrate Roughness Induced by Grit Blasting Upon Adhesion of WC-17%Co Thermal Coatings *Thin Solid Films* 377–378 2000: pp. 657–664.
7. **Vitiaz, P. A., Ivasko, V. S., Iliuscenko, A. F.** The Theory and Practice of Protective Coatings. Minsk: Byelorussian Science, 1998: 583 p. (in Russian).
8. **Zimon, A. D.** Adhesion of Tapes and Coatings. Moscow: Chemistry, 1977: 353 p. (in Russian).
9. **Li, C. J., Wang, Y. Y., Wu, T., Ji, G. C., Ohmori, A.** Effect of Types of Ceramic Materials in Aggregated Powder on the Adhesive Strength of High Velocity Oxy-fuel Sprayed Cermet Coatings *Surface and Coatings Technology* 145 2001: pp. 113–120.
10. **Chasui, A., Marigaki, O.** Welding and Spraying. Moscow: Mechanical Engineering, 1985: 231 p. (in Russian).
11. **Tusinski, L., Plochov, A. V.** Research of Structure and Physico-mechanical Properties of Coatings. Novosibirsk: Science, 1986: 199 p. (in Russian).
12. **Shaw, L., Ren, R., Goberman, D.** Measurements of the Fracture Energy of the Coating/Substrate Interfacial Region Through Radial-Notched Cylindrical Specimens *Surface and Coatings Technology* 130 2000: pp. 74–79.
13. **Tillmann, W., Vogli, E., Baumann, I.** Influence of the HVOF Gas Composition on the Thermal Spraying of WC-Co Submicron Powders to Produce Superfine Structured Hard Material Coatings *International Thermal Spray Conference*, Maastricht, Netherlands, 2008: pp. 956–963.
14. **Zeng, Z., Sakoda, T., Okayama, J., Kuroda, S.** Structure and Corrosion Behaviour of 316L Stainless Steel Coatings Formed by HVOF Spraying *International Thermal Spray Conference*, Maastricht, Netherlands, 2008: pp. 387–392.
15. **Mizuno, H., Aoki, I., Tawada, H., Ibe, H., Sato, K., Kitamura, J.** Cavitation Erosion for WC Cermet Coating Prepared by HVOF *International Thermal Spray Conference*, Maastricht, Netherlands, 2008: pp. 54–57.

