

## Laser Treatment of PVD Coated Carbon Steels and Powder Steels

Andrei SURZHENKOV<sup>1\*</sup>, Priit KULU<sup>1</sup>, Andre GREGOR<sup>2</sup>, Petri VUORISTO<sup>2</sup>,  
Jyrki LATOKARTANO<sup>2</sup>, Mikko RUPPONEN<sup>2</sup>

<sup>1</sup>Department of Materials Engineering, Tallinn University of Technology, Ehitajate tee 5, 19086 Tallinn, Estonia

<sup>2</sup>Laser Application Laboratory, Tampere University of Technology, Korkeakoulunkatu 6, 33101 Tampere, Finland

Received 01 June 2008; accepted 29 June 2008

In the present study, the opportunities of laser beam treatment by the means of the 4 kW Nd:YAG laser are investigated. The studied materials are carbon steels C 45 and C22E (carburized), coated with the PVD coatings Ti(C,N), TiN and (Al,Ti)N, and powder steel Vanadis 6. The macrophotos of the laser beam treated surfaces were taken, the microstructures of the cross-sections of laser beam treated specimens were studied, and the microhardness profiles of the cross-sections of laser beam treated specimens were made. As these studies have shown, no signs of the influence of laser beam appear at the surface of the PVD coatings, until an energy input threshold is reached, after that the coating oxidizes and degrades. No hardened zones were found under the PVD coatings, except for (Al,Ti)N coating. In the case of steel Vanadis 6, three distinct zones can be seen. In the first zone, the carbide particles have dissolved, and a dendritic structure has appeared. In the second zone, the carbide particles remained, however, they were of smaller size in comparison with the initial structure. In the third zone, the initial structure remained. The growth of microhardness values was observed in the first and in the second zone, whereas bigger values were obtained in the second zone.

*Keywords:* laser beam treatment, PVD coatings, powder steels.

### 1. INTRODUCTION

The usage of hard physically vapour deposited (PVD) coatings has gained much acknowledgement as a way to remarkable improvement of tribological and corrosion resistance properties of a material. However, their application is restricted by the possibility of plastic deformation of the substrate [1 – 5], as the coatings themselves are very thin, and the load is to be carried by the substrate. To resist this, different pre- and after-treatments of the substrate are applied.

Among other techniques, laser beam treatment is attracting strong attention [6]. In comparison to other methods, it allows to obtain bigger substrate hardness values, than other heat treatment methods, lower distortion of the surface. In addition to that, laser beam treatment is highly localized [7].

The aim of this study was to investigate the opportunities of laser beam treatment of carbon steels with Ti(C,N), TiN and (Ti,Al)N PVD coatings, as well as powder steels.

### 2. EXPERIMENTAL

#### 2.1. Preparation of the specimens

The chemical composition of steels, used in this work, is presented in Table 1. Specimens of four different sizes were used. Specimens, made of steel C 45, were machined to sizes of (30 × 30 × 5) mm and (15 × 25 × 5) mm. Specimens, made of steel C22E, had dimensions Ø 30 mm × 5 mm. Specimens, made of steel Vanadis 6, were of (25 × 30 × 5) mm size.

Specimens, made of steel C22E, were subjected to pack carburizing during 6 hours at the temperature of 900 °C. The depth of the carburized layer was approximately 1 mm.

Specimens, made of steels C 45 and C22E, were grinded and polished using silicon carbide based grinding papers with grit sizes, gradually decreasing from 80 to 4000. Specimens, made of steel Vanadis 6, were polished with grinding papers with grit sizes gradually decreasing from 80 to 400.

The physical vapor deposition process was applied on specimens, made of steels C 45 and C22E. For the physical vapor deposition process, the PLATIT  $\pi^{80}$  hard-coating system was applied. The standard Ti(C,N) and (Al,Ti)N coatings were applied to specimens, made of steel C22E, and the standard Ti(C,N), (Al,Ti)N and TiN coatings were applied to the specimens, made of steel C 45. The thickness of the coatings equalled to 2,5  $\mu$ m in all the cases.

#### 2.2. Laser treatment stage

Laser beam treatment was performed using the Haas HL4006D 4 kW Nd:YAG laser with the wavelength of 1064 nm. The laser was operated in the CW mode, the dimensions of a laser spot were set as 4 mm × 9 mm. Treatment zone was shielded with argon at the flow rate of 20 l/min. Three passes without overlapping were applied to each specimen, treated at final sets of parameters. The principle scheme of a laser beam treatment is presented by Fig. 1. The final treatment parameters are brought at Table 2.

The choice of final parameters of treatment was partially dictated by [11], partially by the preliminary experiments' data. TiN and (Al,Ti)N coatings were treated, using lower laser beam power, to avoid their destruction.

\*Corresponding author. Tel.: + 372-5102198; fax.: + 372-6202020.  
E-mail address: andrei.surzenkov@ttu.ee (A. Surzenkov)

**Table 1.** Chemical composition of the used steels

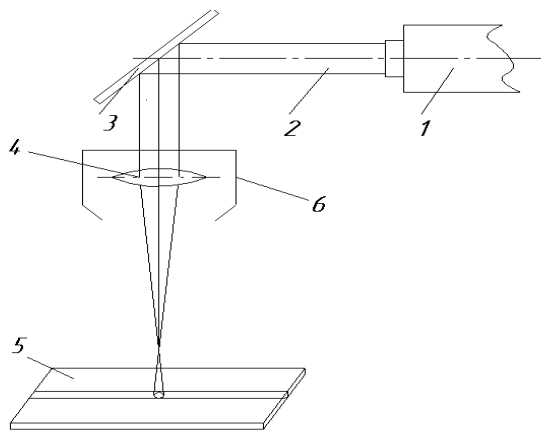
Steel grade	C, %	Si, %	Mn, %	Cr, %	Mo, %	V, %	P, %	S, %
C 45	0.42 – 0.50	0.17 – 0.37	0.50 – 0.80	–	–	–	< 0.035	< 0.035
C22E	0.17 – 0.24	0.17 – 0.37	0.40 – 0.70	–	–	–	< 0.035	0.020 – 0.040
Vanadis 6	2.6	1.0	0.4	6.8	1.5	5.4	–	–

**Table 2.** Final parameters of the laser treatment

Coating or steel grade	Steel grade of the substrate	Laser beam power, W	Scan speed, mm/min
Ti(C,N)	C22E	600	300
	C 45	600	300
(Al,Ti)N	C22E	500	300
	C 45	500	300
TiN	C 45	500	300
Vanadis 6	–	1000	300

### 2.3. Obtained data evaluation

Macrophotos of the laser beam treated surface were made using Canon EOS 350D camera. To reveal the microstructures of laser treated specimens' cross-sections, the latter were polished, etched with nital and studied under the Axiovert 25 (Carl Zeiss, Germany) optical microscope. In addition to that, the Vickers microhardness profiles were obtained applying the Buehler Micromet 2001 microhardness tester. The load was 0.3 kg.



**Fig. 1.** The principle scheme of laser beam treatment: 1 – laser, which is operated in a pulsed or continuous wave mode, 2 – laser beam, 3 – turning mirror, 4 – optical system, 5 – specimen, 6 – nozzle for the gas feed

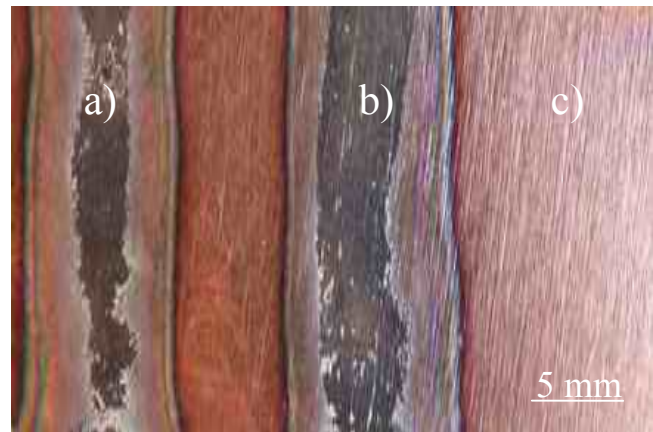
## 3. RESULTS AND DISCUSSION

### 3.1. Surface macrostructure

In the case of PVD coatings, no visible changes of the surfaces' conditions were noticed. However, when a certain threshold of energy input is exceeded, the coating is oxidized and removed from the substrate. Fig. 2 illustrates this case for the TiCN coating on carburized steel C22E.

In this case, three single passes at laser beam power values of 710 W, 650 W and 600 W (at Fig. 2, a, b and c respectively) at the constant speed of 300 mm/min were applied to the specimen. As it can be seen, degradation of the coating takes place in the middle of the laser beam treated zone. This can be explained by the different expansion coefficients of Ti(C,N) coating and the

substrate. At the expense of that tensile stresses appear in the coating that leads to its degradation. Apart from that, the austenite-to-martensite transformation can be also partially responsible for the destruction of the coating, as the martensitic structure was found in the coating-free treated zone of the specimen, and the austenite-to-martensite transformation is followed by the size alterations.



**Fig. 2.** The surface of laser beam treated Ti(C,N) coating, carried onto the carburized steel C22E. Scan speed 300 mm/min, laser beam power values: a) 710 W; b) 650 W; c) 600 W

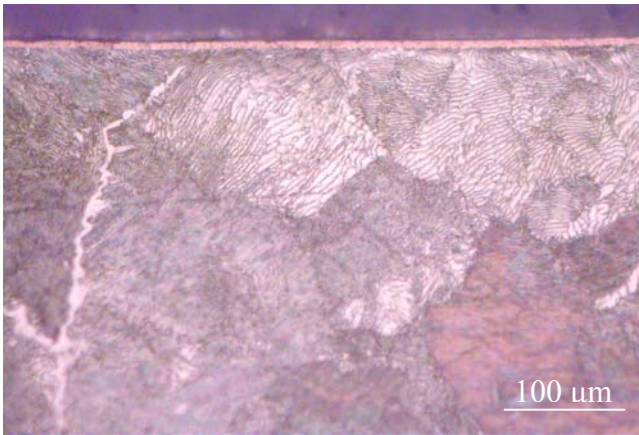


**Fig. 3.** The surface of laser beam treated steel Vanadis 6. Scan speed 300 mm/min, laser beam power 1000 W

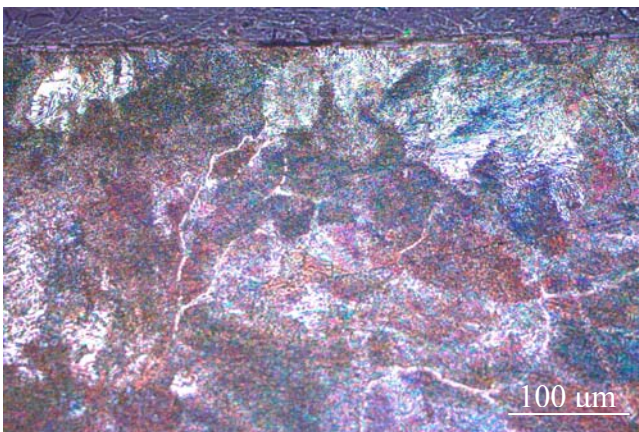
Fig. 3 represents the laser beam treated surface of steel Vanadis 6, where all three passes were completed, applying the final set of parameters. In this case, the surface melted significantly, whereas, as it can be seen, there is a clearly distinct border between the laser beam treatment zone and the surface, left untreated. In addition to that, it can be seen that at one edge the specimen has melted in a more dramatic way. The possible explanation for it is that the more melted zone appeared during the last pass, made by laser. In such case, the specimen is heated to a bigger extent, than at the beginning of treatment, thus the temperature in the zone of the third pass is higher.

### 3.2. Microstructure

Figs. 4 and 5 show the laser beam treated zones of carburized steel C22E specimens, which were coated with Ti(C,N) and (Al,Ti)N coatings, respectively. As it can be seen, no visible effect of treatment is present. The possible reason for it is that the temperature under the coating didn't exceed the phase transformation temperature.

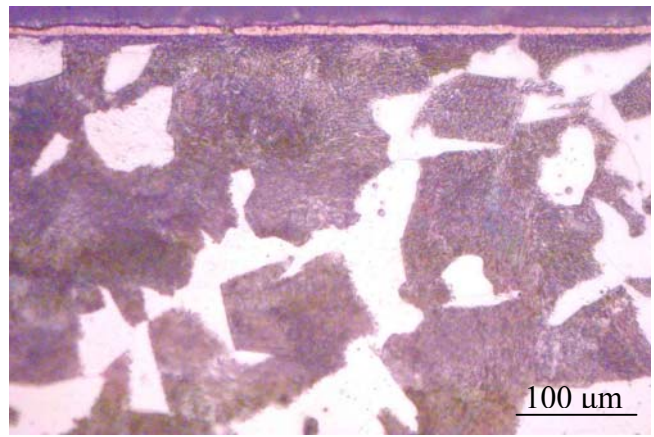


**Fig. 4.** Microstructure of laser beam treated carburized steel C22E, coated with the Ti(C,N) coating. Scan speed 300 mm/min, laser beam power 600 W

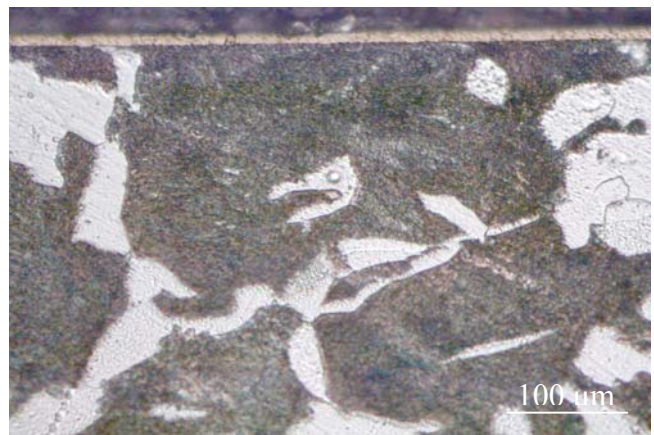


**Fig. 5.** Microstructure of laser beam treated carburized steel C22E, coated with the (Al,Ti)N coating. Scan speed 300 mm/min, laser beam power 500 W

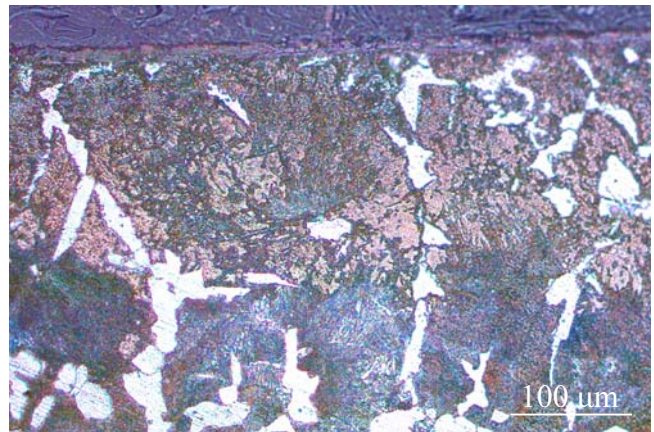
Figs. 6 and 7 illustrate the laser beam treated zones of steel C 45, coated with Ti(C,N) and TiN PVD coatings, respectively. Neither in the first case nor in the second one any signs of phase transformation could be seen. The possible reason for it is that the phase transformation temperature has not been reached.



**Fig. 6.** Microstructure of laser beam treated steel C 45, coated with the Ti(C,N) coating. Scan speed 300 mm/min, laser beam power 600 W



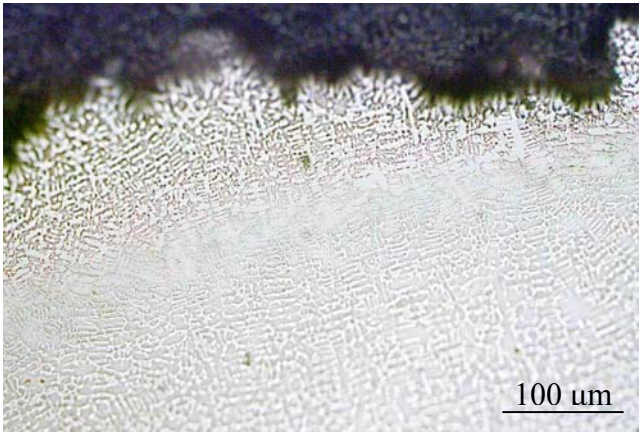
**Fig. 7.** Microstructure of laser beam treated steel C 45, coated with the TiN coating. Scan speed 300 mm/min, laser beam power 500 W



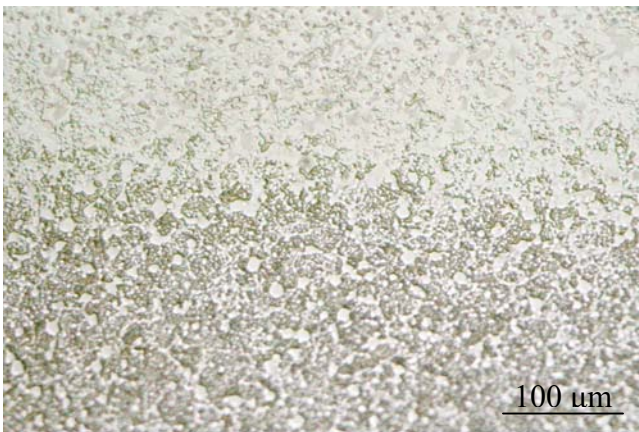
**Fig. 8.** Microstructure of the laser beam treated steel C 45, coated with the (Al,Ti)N coating. Scan speed 300 mm/min, laser beam power 500 W

Fig. 8 illustrates the structure of the laser beam treated steel C 45, coated with the (Al,Ti)N coating. The presence of small amounts of martensite can be seen. Such small amounts of martensite can be explained by an insufficient heating during the treatment. The reason, why such effect has not found place in the case of carburized steel C22E, can be the relatively large grains, which were not heated enough for the martensitic structures to appear.

Figs. 9 and 10 represent the microstructure of laser beam treated steel Vanadis 6. As it can be seen, two zones can be distinguished in the laser beam affected area. The first one, which is situated near the surface of the specimen, has a dendritic eutectic two-phase structure, whereas dendrites are mostly situated perpendicular to the direction of heating. This shows that in this case heat spreads rather by heat conductivity than by convection.



**Fig. 9.** Microstructure of the laser beam treated steel Vanadis 6. The first zone of the laser beam affected area. Scan speed 300 mm/min, laser beam power 1000 W



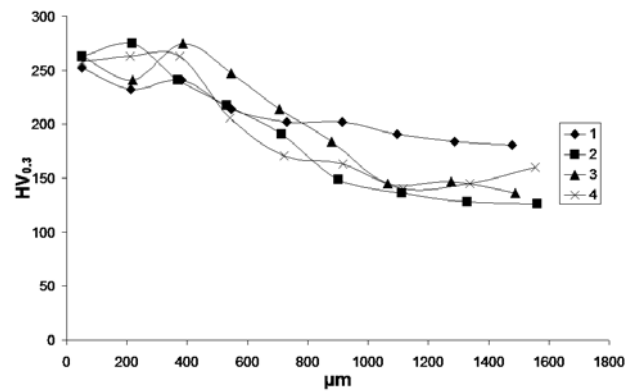
**Fig. 10.** Microstructure of the laser beam treated steel Vanadis 6. The second zone of the laser beam affected area. Scan speed 300 mm/min, laser beam power 1000 W

The second zone, situated near the untreated material, has a structure of the eutectic two-phase matrix with the dispersed carbide particles, whereas the latter are smaller than in the untreated material.

### 3.3. Microhardness

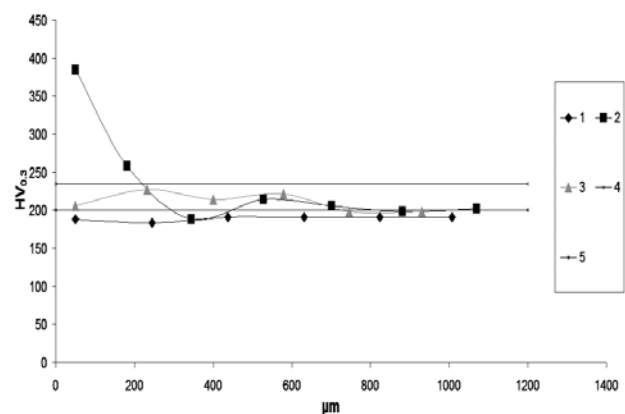
Fig. 11 represents the microhardness profiles of the cross-section of steel C22E laser beam treated specimens, coated with the Ti(C,N) and (Al,Ti)N coatings. In comparison, the microhardness profiles of the cross-sections of the untreated steel C22E specimens with the same coatings are brought.

As it can be seen, no hardening effect has found place. This can be explained by the insufficient heating by the laser beam.



**Fig. 11.** The microhardness profiles of laser beam treated steel C22E specimens with PVD coatings: 1 – Ti(C,N), 2 – (Al,Ti)N, 3 – Ti(C,N), untreated, 4 – (Al,Ti)N, untreated

Fig. 12 shows the microhardness profiles of the cross-section of the laser beam treated steel C 45 specimens, coated with the coatings Ti(C,N), (Al,Ti)N and TiN coatings. In addition to them, the two horizontal lines illustrate the maximal and minimal microhardness values, obtained in the steel C 45 untreated specimens.

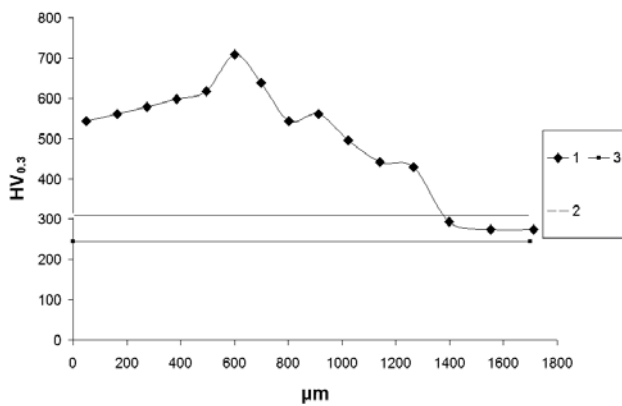


**Fig. 12.** The microhardness profiles of the laser beam treated steel C 45 specimens with the PVD coatings: 1 – Ti(C,N), 2 – (Al,Ti)N, 3 – TiN, 4 – C 45, untreated, maximal microhardness, 5 – C 45, untreated, minimal microhardness

As it can be seen, except for the specimen, coated with the (Al,Ti)N coating, where a hardened zone of about 200 μm appeared, no hardening effect can be seen. The possible reason for it is that the phase transformation temperature has not been reached in the majority of cases.

Fig. 13 represents the microhardness profile of the cross-section of the laser beam treated steel Vanadis 6.

As it can be seen, the depth of the hardened zone reaches 1400 μm, whereas the maximal microhardness value is approximately at the depth of 600 μm. Such distribution of the microhardness values can be explained by the fact that the microhardness of the eutectic, what formed at the top of the laser beam affected zone, has lower microhardness values than the structure in the middle of the laser beam affected zone. In its turn, it can be explained by the dissolution of carbides at the top of the laser beam affected zone, and the appearance of more



**Fig. 13.** The microhardness profile of the laser beam treated steel Vanadis 6 specimen: 1 – microhardness profile of the laser beam treated zone, 2 – steel Vanadis 6, untreated, maximal microhardness, 3 – steel Vanadis 6, untreated, minimal microhardness

dispersed carbides at the lower part of the laser beam affected zone.

#### 4. CONCLUSIONS

1. No hardening effect is present in the steel C22E specimens with the given PVD coatings, treated at the current sets of parameters.
2. It is not recommended to carry out the laser beam treatment for the PVD Ti(C,N) coatings, being carried onto a carburized substrate, as the coating degrades before any hardening effect is achieved.
3. No signs of the hardening effect were found in the steel C 45 specimens with the Ti(C,N) and TiN coatings.
4. The depth of the hardened zone in the steel C 45 specimen with the (Al,Ti)N coating equaled to 200 μm, the maximal microhardness value was approximately 385 HV<sub>0.3</sub>.
5. The depth of the hardened zone in the steel Vanadis 6 specimen was approximately 1400 μm, the biggest microhardness value in that zone equaled to approximately 710 HV<sub>0.3</sub>.
6. It is recommended to avoid dissolution of carbides in the powder steel Vanadis 6 during the laser beam hardening, as it doesn't allow to obtain the maximal microhardness values.
7. The maximal microhardness values in the case of the steel Vanadis 6 appear, when the dispersed carbides are present in the structure.

#### Acknowledgments

The authors thank Endel Mens and Priidu Peetsalu from Tallinn University of Technology, as well as Eron Adolberg for the help during the preparation of the specimens and their investigation.

#### REFERENCES

1. **Batista, J. C. A., Godoy, C., Matthews, A.** Micro-scale Abrasive Wear Testing of Duplex and Non-duplex PVD (Ti,Al)N, TiN and Cr-N Coatings *Tribology International* 35 2002: p. 383.
2. **Batista, J. C. A., Godoy, C., Buono, V. T. L., Matthews, A.** Characterization of Duplex and Non-duplex (Ti,Al)N and Cr-N PVD Coatings *Materials Science and Engineering A* 336 2002: p. 40.
3. **Alsaran, A., Çelik, A., Çelik, C., Efeoğlu, İ.** Optimization of Coating Parameters for Duplex Treated AISI 5140 Steel *Materials Science and Engineering A* 371 2004: p. 141.
4. **Lee, S. Y.** Mechanical Properties of TiN<sub>x</sub>/Cr<sub>1-x</sub>N Thin Films on Plasma Nitriding-assisted AISI H13 Steel *Surface & Coatings Technology* 193 2005: p. 55.
5. **De Las Heras, E., Egidi, D. A., Gorengia, P., González-Santamaria, D., Garsía-Luis, A., Brizuela, M., López, G. A., Flores Martinez, M.** Duplex Surface Treatment of an AISI 316L Stainless Steel; Microstructure and Tribological Behavior *Surface & Coatings Technology* 202: p. 2496.
6. **Sacher, G., Zenker, R.** Subsequent Heat Treatment of Hard Coated Steels by Electron or Laser Beam *German-Russian Workshop Tribology and Surface Engineering: Theory, Experiment, Technologies* Berlin University of Technology, March 28–30, 2007.
7. **Rykalin, N. N., Uglov, A. A., Zuev, I. V., Kockorah, A. N.** Laser and Electron Beam Treatment of Materials. Mashinostroyeniye, Moscow, 1985: p. 206 (in Russian).
8. **Steels and Cast Irons. Standards (Grading, Composition, Properties). Matching.** Ed. Kulu, P. Eesti Välismajanduse Teataja, Tallinn, 2001: pp. 17, 50 (in Estonian).
9. **Eurometals. Steels, Cast Irons, Aluminum Alloys, Copper Alloys.** Ed. Kulu, P. Tallinn, 2001: p. 1.154 (in Estonian).
10. **Mechanical Production Engineer's Handbook. Vol. 1.** Ed. Kosilova, A., Mestseryakov, R., Mashinostroenie, Moscow, 1986: p. 128 (in Russian).
11. **Adamiak, M., Dobrzański, L.** Microstructure and Selected Properties of Hot-work Tool Steel with PVD Coatings After Laser Surface Treatment *Applied Surface Science* 254 2008: pp. 4552 – 4556.
12. **Grigorjants, A., Saphronov, A.** The Methods of Laser Beam Surface Treatment. Vysshaja shkola, Moscow, 1987 (in Russian).

Presented at the 17th International Conference "Materials Engineering'2008" (Kaunas, Lithuania, November 06–07, 2008)

