

Shear Strength and Modulus of Elasticity of Expanded Polystyrene (EPS)

Sigitas VĖJELIS*, Ivan GNIP, Saulius VAITKUS, Vladislovas KERŠULIS

Institute of Thermal Insulation, Vilnius Gediminas Technical University Linkmenu st. 28, LT-08217 Vilnius, Lithuania

Received 15 November 2007; accepted 13 August 2008

Expanded polystyrene (EPS) is used in layered elements, in which the EPS midlayer takes up a part of shear stresses. In such construction EPS provides the stability and rigidity of the whole structure. In the present paper shear strength and shear modulus elasticity are determined according to requirements of European norm EN 12090. Single and double specimen test methods were used in the experiments. The shear strength and shear modulus of elasticity were determined using EPS slabs manufactured in different Lithuanian enterprises. Expanded polystyrene slabs with density from 11 kg/m³ to 30 kg/m³ were used in the tests. On the basis of experimental data dependences between expanded polystyrene type and shear strength as well shear modulus are given. It is shown, that the thickness of the sample significantly influences shear strength and shear modulus of elasticity.

Keywords: expanded polystyrene (EPS), shear strength, shear modulus of elasticity, single and double specimen test methods.

1. INTRODUCTION

Thirty years after the introduction of compulsory thermal insulation in most European countries, insulation materials form still the major tools for the improvement of buildings energy behaviour. The use of insulation materials has increased, both in terms of buildings being insulated and in the minimum values of insulation required by the national regulations [1].

Data about applied insulation thickness in new build residential buildings in EU-countries are presented in Fig. 1. In order to have comparable figures for the different thermal performances per centimetre of thickness per insulation type, the results of the average insulation thickness were normalized to a thermal performance based on a default thermal conductivity coefficient $\lambda = 0.040$ W/m·K [2].

Requirements for thermal insulation resistance in Lithuania were changed in 2005 year [3]. Thermal resistance for walls in present time vary from 3.3 m²·K/W to 5.0 m²·K/W and thickness of thermal insulation from 13 cm to 20 cm dependent on the building type.

The European market of insulation materials is characterised by the domination of two groups of products, namely inorganic fibrous materials, glass wool and stone wool, which account for 60 % of the market, and organic foamy materials, expanded and extruded polystyrene and extent polyurethane, which account for some 27 % of the market [1].

Low production costs and simple technologies enable wide application of expanded polystyrene [4–6]. An efficient area of application of expanded polystyrene is layered elements (structural sandwich panels and the external thermal insulation of walls of buildings), in which the EPS midlayer takes up a significant part of shear stresses and provides the stability of covering sheets and the rigidity of the whole structure [7].

Compression under short loading of polystyrene foam is main object of studies [8–12]. Compressible strength of expanded polystyrene is often characterized by its density. When density increases twice, compressible strength increases about 4 times [9]. In [10] it is well studied short-term compression process of EPS in macro and micro level. When the specimen is under compression, the beads move to different directions. It is possible that not only compression stresses but also the tensile as well as shear stresses appear between the beads.

In [13] it is studied deformability and tensile strength of expanded polystyrene under short-term loading. In tests specimens of thickness from 50 mm to 150 mm were used. By analyzing test data it was found that the effect of the specimen thickness on their ultimate tensile strength as well tensile modulus of elasticity was appreciable. When thickness of the specimen increases the tensile strength increases too, while influence of specimen thickness on tensile modulus of elasticity was insignificant and values of modulus were equal at specimen thickness of 100 mm and 150 mm. According to authors, inhomogeneity of expanded polystyrene causes additional scattering of tensile test results.

The shear strength of EPS depends on the quality of fusion and on the density. Temperature and flame retardants also impact shear strength [14]. When temperature increases from 20 °C to 70 °C shear strength may decrease about 2.5 times.

In present study single and double specimen test methods were compared, to determine shear strength and shear modulus of elasticity. Shear strength and shear modulus were determined for different thickness of specimen.

2. EXPERIMENTAL

The shear strength of expanded polystyrene was tested using slabs manufactured at Lithuanian enterprises. The specimens for single test method of (250×50×50) mm and for double test method of (200×100×50/100/200) [15]

*Corresponding author. Tel.: +370-5-2752485; fax.: +370-5-2752485.
E-mail address: Sigitas.Vejelis@termo.vgtu.lt (S. Vėjelis)

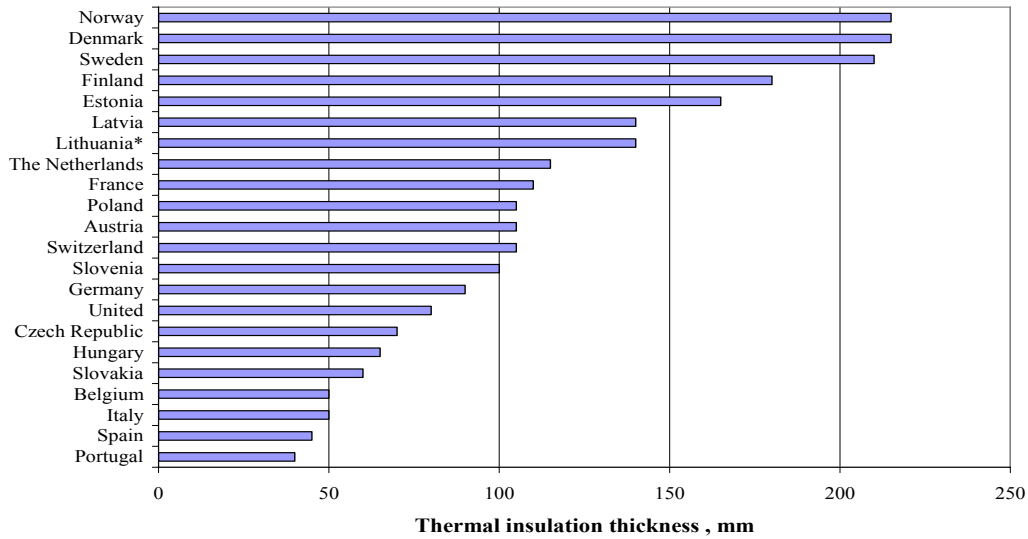

a

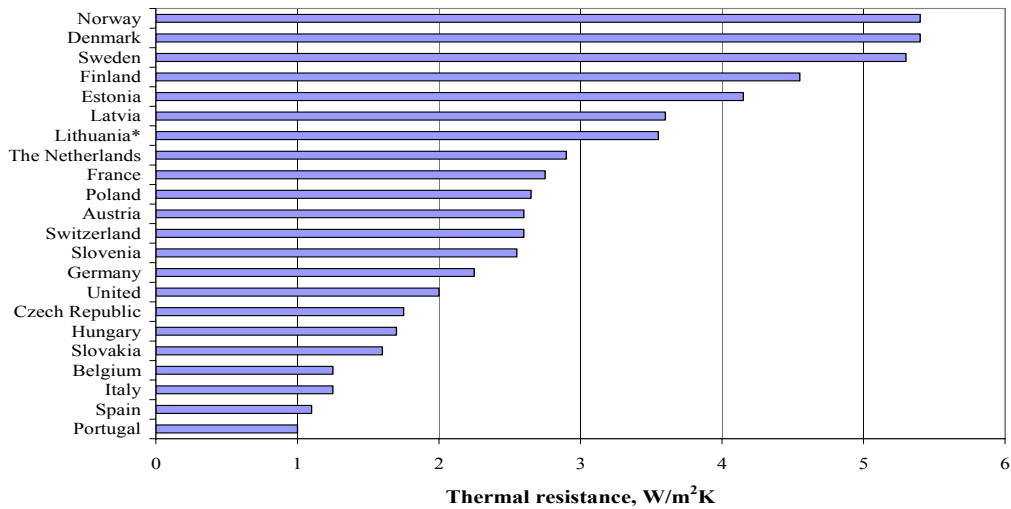

b

Fig. 1. Thermal insulation thickness (a) and thermal resistance (b) of walls in different European countries (* [3] data are changed)

were cut out from boards with density ranging from 11 kg/m^3 to 30 kg/m^3 . Samples from the slabs were cut by a hot wire. By compression strength type expanded polystyrene varied from EPS50 to EPS200 [16]. The specimens were fixed up to the metal plates (Fig. 2) with epoxy. Prior to testing, the specimens were stored for 24 h at a temperature of $(23 \pm 5)^\circ\text{C}$ and $(50 \pm 5)\%$ relative humidity for epoxy setting.

In the experiment H10KS press made by Housfield (England) was used. The machine used in the experiment was connected to a PC. All parameters (measurement of the specimens, speed of the load, etc.) were controlled and monitored by the PC. Shear strength τ , kPa, was calculated by computer program according to formula:

$$\tau = \frac{F_m}{A}, \quad (1)$$

where A is the specimens area, m^2 ; F_m is the maximum force applied to the test specimen, kN. For single test specimen A is calculated as $l \times b$, where l is the length of specimen, m; b is the width of specimen, m; and for double test specimen $2 \times l \times b$.

Shear modulus G , kPa, is calculated using the equation:

$$G = \frac{d \cdot \tan \alpha}{A}, \quad (2)$$

where d is the thickness of test specimen, m; $\tan \alpha$, kN/m, is the slope of the linear portion of the force-displacement curve; $\tan \alpha$ is calculated by formula:

$$\tan \alpha = \frac{F_e}{\gamma_e}, \quad (3)$$

where F_e is the maximum force in the elastic zone, kN; γ_e is the displacement in the elastic zone, m.

3. RESULTS AND ANALYSIS

In present time expanded polystyrene slabs are classified on their type, which is determined by compression test up to 10 % of deformation. EPS type is marked on the each slab at the factory. Results of research of shear strength as well shear modulus of elasticity of expanded polystyrene with thickness of 50 mm are presented in Fig. 3. It is

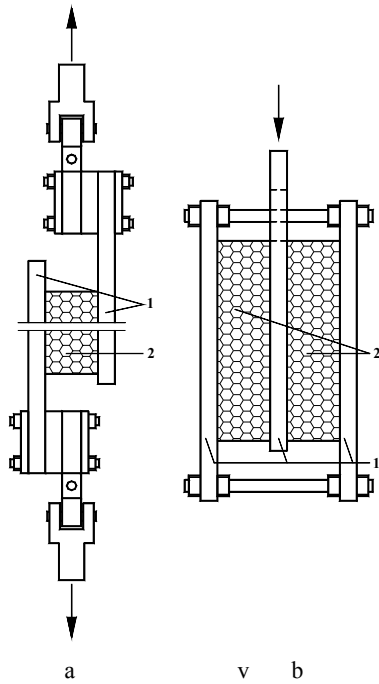

Fig. 2. Schematic of the device for shear testing: a – single specimen test method; b – double specimen test method. 1 – metal plates; 2 – expanded polystyrene

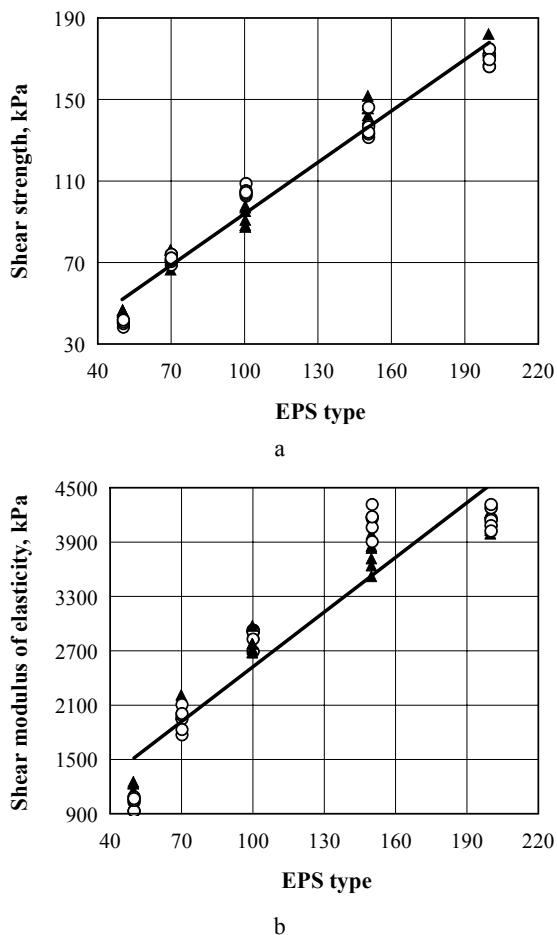

Fig. 3. Dependence of expanded polystyrene shear strength (a) and shear modulus of elasticity (b) on the EPS type. Tested by: ○ – single test method; ▲ – double test method

shown, that by increase of EPS type as well as compressible strength (the type of expanded polystyrene shows compressible strength) increase of shear strength and shear modulus is observed. The figure shows that dependence of expanded polystyrene shear strength and shear modulus on EPS type is linear. There are no differences at application of both test methods or these differences are negligible. The dependence of shear strength on the EPS type may be described by the regression equation:

$$\tau = 0.841T + 9.9, \quad (4)$$

where T is EPS type, with the mean square deviation $S_r = 7.7$, kPa, and the determination factor $R^2 = 0.974$, which shows that variations in shear strength of EPS depend primarily on the EPS type of expanded polystyrene by 97.4 % and only slightly 2.6 % on the action of other factors, disregarded in the system of random variables considered.

The dependence of shear modulus on the EPS type may be described by the regression equation:

$$G = 20.143T + 508.3 \quad (5)$$

with $S_r = 379.3$, kPa, and $R^2 = 0.897$.

Fig. 4 shows the dependence between the shear modulus and shear strength. By increase of one parameter the second parameter increases too. The dependence is linear and may be described by the regression equation:

$$\tau = 0.0389G - 3.3 \quad (6)$$

with $S_r = 11.39$, kPa, and $R^2 = 0.897$, where G is shear modulus of elasticity, kPa.

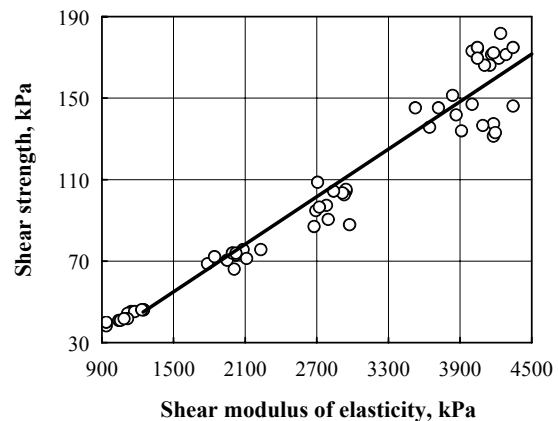
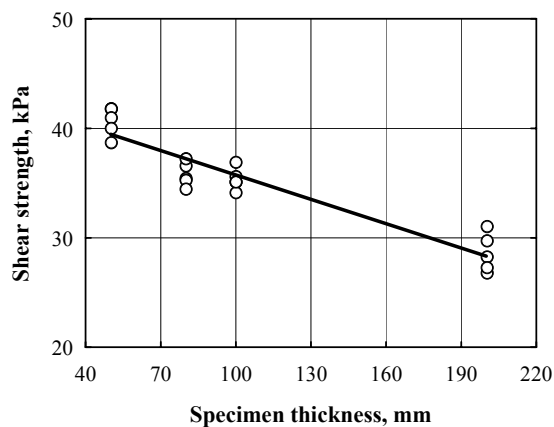

Fig. 4. The dependence between shear modulus of elasticity and shear strength

In practice expanded polystyrene with thickness of 50 mm are commonly used. After the effect of [3] requirements the use of expanded polystyrene of major thickness is increased.

In Fig. 5 the results of dependence of expanded polystyrene thickness on shear strength as well shear modulus are presented. Fig. 5, a, shows that with increase of EPS thickness shear strength decreases. It means that with increase of specimen thickness the influence of bending and tensile stresses in specimen increase significantly. Fig. 5, b, shows the increase of shear modulus by increase of specimen thickness. It associates with an initial section of curve of shear stresses. With increase of specimen



a

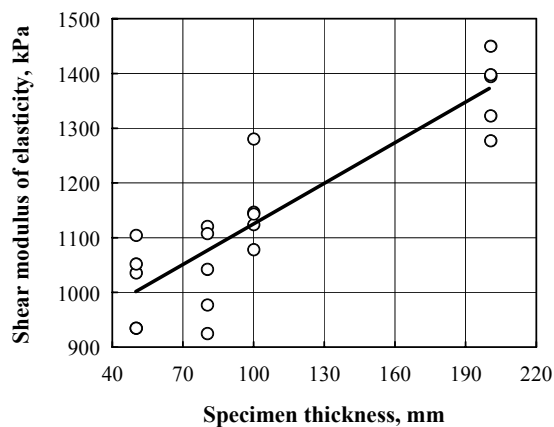

b

Fig. 5. The dependence of EPS50 type between expanded polystyrene thickness and shear strength (a) as well shear modulus (b)

thickness in this section modulus increase too because the rigidity of the specimen is higher while the critical stress is reached.

4. CONCLUSIONS

1. The statistical analysis of the data shows possibilities of determination of shear strength and shear modulus of elasticity of slabs according to their type. There are no differences at application single and double test methods or these differences are negligible.
2. It was shown that with increase of specimen thickness influence of bending and tensile stresses increase. This shows decrease of shear strength. When specimen thickness increases 4 times, shear strength decreases about 1.4 times while the shear modulus increases about 1.4 times. Designing layered elements, in which the EPS midlayer takes up a part of shear stresses, the influence of thickness of thermal insulation material on the stability and rigidity of whole structure must be evaluated.
3. Rigidity of EPS specimens of major thickness at initial section of curve of shear stresses is more. When

critical stress is reached the rigidity of specimens is lost. This influence increase of elastic modulus of expanded polystyrene of major thickness.

REFERENCES

1. **Papadopoulos, A. M.** State of the Art in Thermal Insulation Materials and Aims for Future Developments *Energy and Buildings* 37 2005: pp. 77 – 86.
2. <http://www.eurima.org/>(visited on 30 07 2007).
3. STR 2.05.01:2005. REGULATIONS. Thermal Technique of Envelopes of the Buildings
4. **Mills, N. J., Zhu, H. X.** The High Strain Compression of Closed-Cell Polymer Foams *Journal of the Mechanics and Physics of Solids* 47 1999: pp. 669 – 695.
5. **Lando, L. D., Sala, G., Olivieri, D.** Deformation Mechanisms and Energy Absorption of Polystyrene Foams for Protective Helmets *Polymer Testing* 21 2002: pp. 217 – 228.
6. **Song, B., Chen, W. W., Bou, S., Winfree, N. A., Kang, J. H.** Strain Rate Effect on Elastic and Ealy Cell-Collapse Responses of Polystyrene Foam *International Journal of Impact Engineering* 31 2005: pp. 509 – 521.
7. **Gnip, I. J., Veyelis, S. A., Kersulis, V. I., Vaitkus, S. I.** Deformability and Strength of Expanded Polystyrene (EPS) under Short-Term Shear Loading *Mechanics of Composite Materials* 43 2007: pp. 85 – 94.
8. **Gnip, I. J., Keršulis, V. I., Vaitkus, S. I.** Predicting the Deformability of Expanded Polystyrene in Short-Term Compression *Mechanics of Composite Materials* 41 2005: pp. 105 – 109.
9. **Gnip, I., Keršulis, V., Vaitkus, S., Vėjelis, S.** Assesment of Strength under Compression of Expanded Polystyrene (EPS) Slabs *Materials Science (Medžiagotyra)* 10 (4) 2004: pp. 326 – 329.
10. **Vaitkus, S., Laukaitis, A., Gnipas, I., Keršulis, V., Vėjelis, S.** Experimental Analysis of Structure and Deformation Mechanisms of Expanded Polystyrene (EPS) Slabs *Materials Science (Medžiagotyra)* 12 (4) 2006: pp. 323 – 327.
11. **Horwath, J. S.** The Compressible Inclusion Function of EPS Geofoam *Geotextiles and Geomembranes* 15 1997: pp. 44 – 120.
12. **Duškov, M.** Materials Research on EPS20 and EPS15 under Representative Conditions in Pavement Structures *Geotextiles and Geomembranes* 15 1997: pp. 147 – 181.
13. **Gnip, I. Y., Vėjelis, S., Kersulis, V., Vaitkus, S.** Deformability and Tensile Strength of Expanded Polystyrene under Short-Term Loading *Polymer Testing* 26 2007: pp. 886 – 895.
14. <http://www.eumeps.org/EPS> White Book. EUMEPS Background Information on Standardisation of EPS, Edition 2003.
15. EN 12090:2000. Thermal Insulation Products for Building Application. Determination of Shear Behaviour. 13 p.
16. EN 13163:2001. Thermal Insulation Products for Buildings – Factory Made Products of Expanded Polystyrene (EPS). Specification. 40 p.

DOI: 10.5755/j02.ms.26217