

Microsilica and Plasticizing Admixtures Influence on Cement Slurry Dilatancy

Mindaugas DAUKŠYS^{1*}, Gintautas SKRIPKIŪNAS¹, Ernestas IVANAUSKAS²

¹*Building Materials and Structures Research Centre, Studentų 48, LT-51367 Kaunas, Lithuania*

²*Dept. of Building Materials, Kaunas University of Technology, Studentų 48, LT-51367 Kaunas, Lithuania*

Received 14 January 2008; accepted 25 February 2008

Cement slurries and concrete mixtures have dilatant behaviour in their flow. This has negative influence on the mixtures transportation by concrete pumps. Therefore, it is important to know the factors that have effect on the mixtures dilatancy. The influence of microsilica and plasticizing admixtures on mixtures dilatancy is investigated in this work. Rheological properties of the mixtures were tested with a rotating viscometer with coaxial cylinders. Two indexes of mixtures dilatancy were evaluated as well investigation results of show that microsilica additives increase yield stress of cement slurry and reduce its viscosity and greatly reduce dilatancy of cement slurry due to its particles fineness and its spherical shape. Microsilica suspension with complex used with plasticizing admixtures has different effect on the dilatancy depending on chemical composition of admixture.

Keywords: cement, microsilica, slurry, yield stress, viscosity, viscometer, dilatancy.

INTRODUCTION

The research of cement slurry rheological properties using rotational viscometer with coaxial cylinders revealed that cement slurries behaviour as Bingham plastic fluid and may be characterized by shear stresses (Pa) and plastic viscosity (Pa·s). Previous experiments revealed that cement slurries are dilatant materials [1–4] possessing thixotropic properties [5, 6], i.e. rheological characteristics of the cement slurries depend on mechanical impact. Thixotropy usually becomes apparent during vibration when shear stress and viscosity go down. The system becomes dilatant when viscosity increases with increased shear stress.

The most common explanation of dilatancy is the example of walking on the beach when wet sand around and under your footsteps becomes ‘dry’, however it gets wet again as you walk away. The authors [7, 8] explain this phenomenon by the change of volumetric distribution and increased porosity of sand particles. Part of the water penetrates into the opened pores and the sand becomes ‘dry’. When the pressure from the foot stops, the sand particles return to their previous position, the porosity reduces and free water comes up.

The first investigation into dilatancy phenomenon was carried out by O. Reynolds [9]. According to the author, the increase of system viscosity can be explained by the increase of disperse system volume after the change of solid particles volume displacement caused by the movement of particles to each other. The disperse system volume increase causes the relative decrease of disperse medium volume and the increase of system viscosity. Solid pyramidal particle distribution takes up a minimum volume. After affect of shear force the volumetric distribution of solid particles can be changed to cubic distribution that will increase the volume occupied by solid particles by 1.41 times.

H. Freundlich and H. Roder [10] described the mechanism of dilatancy using the experiment with quartz

and starch water suspensions, where volumetric concentration of solid particles was 0.42–0.45. When suspension flow rates are low, solid particles can slide against each other without any significant distortion of the system that causes the system to thicken. When suspension flow rates are high, the system structure is distorted and interacting particles form a more open structure. The dosage of liquid phase in the system decreases as a result of bigger hollow spaces between the particles and the system stiffens. The dosage of liquid phase is insufficient to reduce friction between solid particles. Dilatancy of disperse systems has not been researched completely as in many cases the nature of dilatancy remains unclear.

According to the authors [11], yield stress of cement slurry go down by increasing the dosage of dispersive additives, however viscosity of the slurry changes depending on the additive type and content. According to the effect on yield stress of the slurry diffusing admixtures may be classified as follows: blast furnace slag > limestone > > microsilica > fly ash (replacing 10 % of cement content by these admixtures). When 35 % of the blast furnace slag is added yield stress and viscosity of the slurry are significantly reduced. Ch. F. Ferarri, K. H. Obla and R. Hill having researched the effect of different mineral admixtures and determined that fine fly ash particles had the biggest effect on reducing yield stress and viscosity of the slurry [12].

F. Cursio, B. A. De Angeli analyzed cement slurries with rotational viscometer, compared rheological properties of the slurry with metakaolin and microsilica and determined that slurries with metakaolin possess less thixotropy, while microsilica increases the thixotropy of the slurry [13]. Dilatancy is explained as friction in suspension between contacting hard angular and flat metakaolin particles. Dilatancy depends on the rate of water and binding material, metakaolin content and fineness. M. Cyr, C. Legrand, M. Mouret researched the effect of mineral admixtures on dilatancy of the slurry and determined that metakaolin increases dilatancy of the slurry, quartz and fly ash have no effect, while microsilica reduces dilatancy of the slurry [14].

*Corresponding author. Tel.: +370-37-455120; fax.: +370-37-300497.
E-mail address: mindaugas.dauksys@ktu.lt (M. Dauksys)

According to the authors [15], active dispersive additives due to their big specific surface area increase water content required to prepare cement slurry of required consistency. Active dispersive additives used together with plasticizing admixtures change diffusive properties of the adsorption layer of the cement particles and accelerate hydration of cement, however reduce the plasticizing effect on the cement slurry.

J. Gallias and co-authors [16] analyzed the effect of granulometric characteristics of mineral additives (suspensions of finely ground quartz, dolomite, diatomite, kaolin, limestone and microsilica) on cement slurry water demand to obtain the required workability of the slurry without using chemical admixtures which decrease water demand. Cement slurry water demand depends on the specific surface area (m^2/kg) of fine ground mineral additives used. Irregular particle morphology of certain mineral additives significantly increases water demand. In the opinion of the authors, mineral additives with broad particle size distribution may reduce cement slurry water demand.

A. Sicker and co-authors [17], having analyzed the effect of different tuffs (microsilica suspension and metakaolin particles) and superplasticizers of different chemical composition to rheological properties of the mortar, determined that viscosity rate of the mortar with microsilica suspension and different plasticizers was lower compared to the viscosity rate of mortar with metakaolin and the same chemical admixtures.

The purpose of this research was to analyze the effect of microsilica suspension and plasticizers of different chemical composition on rheological properties of cement slurries by using a rotational viscometer with coaxial cylinders and offer dilatancy assessment ratios.

EXPERIMENTAL PROCEDURE

For the test JSC "Akmenės cementas" Portland cement CEM I 42.5 R was used. Water demand for normal consistency Portland cement slurry – 27.5 %, specific surface area – $353 \text{ m}^2/\text{kg}$, particle density – $3110 \text{ kg}/\text{m}^3$, dry bulk density – $1220 \text{ kg}/\text{m}^3$. The active dispersive additive used was microsilica (SiO_2) suspension Centrilit Fume S (SF) with particle size 50–100 times smaller than cement particle size, suspension density – $1380 \text{ kg}/\text{m}^3$, solid substance content – $50 \pm 1 \%$. The cement slurry was mixed manually about 5 min. Cement and microsilica shape and surface area microscopic tests were performed using a scanning electron microscope JSM-5600 (firm JEOL). The surface tension of microsilica and cement and microsilica suspensions was determined by Rebinder apparatus while measuring the maximum pressure of gas bubbles.

The plasticizing admixtures used are as follows: plasticizer SMR (L) based on lignosulphonates, solution density – $1.14 \text{ kg}/\text{l}$; superplasticizer Rebamix F2 (FM) (SNF) based on naphtalenformaldehyde resin, the solution density – $1.09 \text{ kg}/\text{l}$, superplasticizer Glenium 127 (PP) based on polycarboxyl polymers, the solution density $1.10 \text{ kg}/\text{l}$. The plasticizing admixtures were mixed with water, used for slurry preparation. Total dosage of admixtures was in the range from 0.2 % to 1.0 % of cement mass.

The cement slurries rheological properties were tested using a rotational viscometer with coaxial cylinders BCH-3. The simplified scheme of the rotational viscometer is displayed on Figure 1.

The cement slurry is poured into a container (3) (external cylinder), which is fixed non-movably into the equipment stand. Inside the external the internal cylinder (2) can rotate. Because of the intrinsic friction of the layers of the cement slurry (4) appearing between the rotating internal cylinder and the cylinder (1) positioned in the internal cylinder and connected to a measuring scale; the internal cylinder (1) makes a turn and the data displayed on the measuring scale changes. The gap between the rotating internal cylinder (1) and the cylinder inside it is 2 mm.

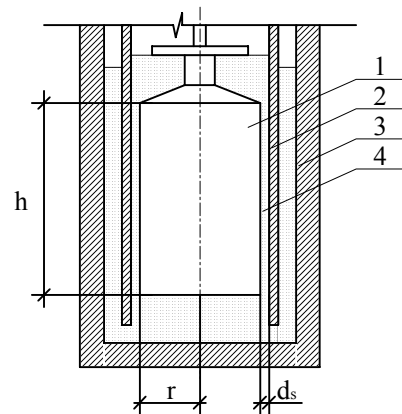

Fig. 1. Scheme of the rotational viscometer with coaxial cylinders: 1 – cylinder connected with measuring scale ($r = 20 \text{ mm}$, $h = 60 \text{ mm}$); 2 – internal (rotating) cylinder; 3 – external (fixed) cylinder; 4 – cement slurry

The cement slurry viscosity is tested at various speeds of the rotating cylinder – 200, 300, 400, 600 r.p.m. According to the scale display, the shear force F (mN) is calculated out on the calibration curve. The calibration curve depends on viscometer springs stiffness.

Shear rate $\bar{\gamma}$, for the different rotating speed of the cylinder (2), is calculated using the equation:

$$\bar{\gamma}_i = \frac{2\pi \cdot r \cdot n_i}{d_s}, \text{ s}^{-1} \quad (1)$$

where: r is the radius of cylinder, connected to the scale, m; n_i is the cylinder rotation speed ($i = 1, 4$), r.p.m.; d_s is the distance between the (1) and (2) cylinders, m.

Shear stresses τ in cement slurry, are calculated using the equation:

$$\tau_i = \frac{F_i}{2\pi \cdot r \cdot h}, \text{ Pa}, \quad (2)$$

where: F_i is the shear force, calculated from the calibration curve according to the scale turning angle, mN; r and h are the radius and height (m) of the cylinder, connected to the measuring scale.

The viscosity of cement slurry η_i , is calculated using the equation:

$$\eta_i = \frac{\tau_i - \tau_0}{\bar{\gamma}_i}, \text{ Pa}\cdot\text{s} \quad (3)$$

where: τ_0 is the yield stress, found out of $\bar{\gamma}-\tau$ curve – the point, in which the curve crosses τ axis.

Cement slurry dilatancy is suggested to evaluate using the index D , which is calculated by increment of viscosity caused by shear stress increase using the equation [1–3]:

$$D = \frac{\Delta\eta}{\Delta\tau} \cdot \frac{\text{Pa} \cdot \text{s}}{\text{Pa}}, \quad (4)$$

where: $\Delta\eta$ and $\Delta\tau$ are the cement slurries viscosity (Pa·s) and shear stresses (Pa) differences, when the shear rate are is 630 s^{-1} and 205 s^{-1} .

It is advisable to calculate the dilatancy ratio D at the lowest and the highest shear stress obtained by measuring rheological properties of the cement slurry, depending on the viscometer. The cement slurry dilatancy index D shows the increase of viscosity caused by shear stress increment from 205 s^{-1} to 630 s^{-1} .

The cement slurry dilatancy can be evaluated by another index D_1 , which can be calculated from the viscosity curve inclination angle versus the shear rate. The dilatancy index D_1 can be calculated from equation:

$$D_1 = \text{tg}\alpha = \frac{\Delta\eta}{\Delta\gamma}, \text{ Pa} \cdot \text{s}^2 \quad (5)$$

where: α is the angle of viscosity curve to shear rate axis. The tangent line is obtained from the viscosity curve by approximating viscosity values using linear function.

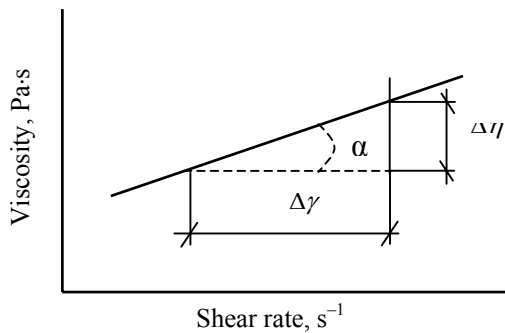

Fig. 2. Viscosity of slurry or mixture dependence on shear rate

Dilatancy index D_1 describes the increment of viscosity of slurry or mixture increasing the shear rate from 205 s^{-1} to 630 s^{-1} .

The dilatancy indexes D or D_1 can be calculated subject to the factors analyzed the flow – shear stress or share rate.

RESULTS AND DISCUSSIONS

The flow curves of cement slurry ($W/C = 0.55$) with different dosage of microsilica suspension (Centrilit Fume S (SF)) (replacing 3%–12% of cement content) are presented in Fig. 3. The inclination angle of flow curves show that microsilica suspension reduces the dilatancy of cement slurry. When 3% and 6% of cement mass is replaced by active mineral additives, the flow curves come closer to a line compared with the slurry without additive. When 9% of cement mass are replaced by active mineral additive, the flow curve corresponds to the linear Bingham model. With the biggest dosage of microsilica additive, the flow curve corresponds to the pseudo plastic fluid flow curve.

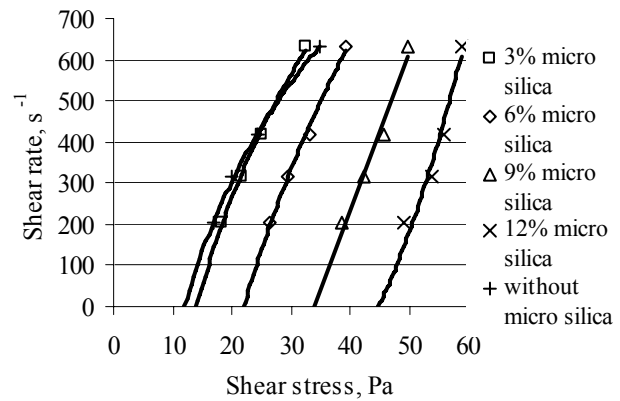
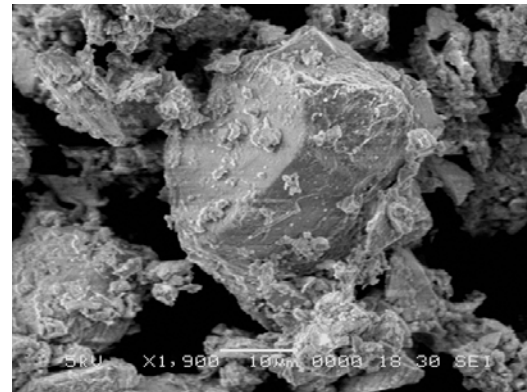
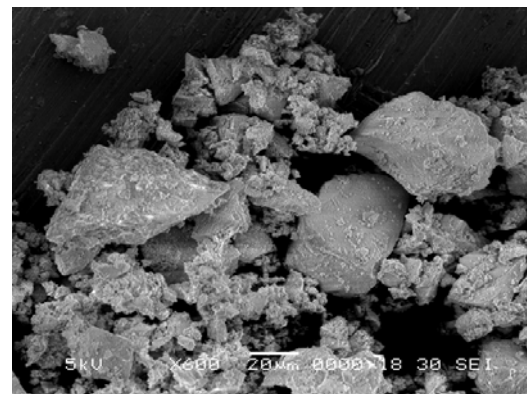

Fig. 3. Dependence of the Portland cement slurry shear rate on shear stress when 3%–12% of cement mass is replaced by microsilica additive

Analysis of cement particles by electronical scanning microscope showed that the edges of most Portland cement particles are polished during grinding, therefore most of these particles have a shape similar to a cube or even a sphere (Fig. 4, a and b).



a



b

Fig. 4. Microphotographs: Portland cement particle (a) and Portland cement particle accumulations (b)

This finding was made after random microscopic analysis of forty Portland cement particles, which diameter was about $3 \mu\text{m}$ – $60 \mu\text{m}$.

Microscopic analysis results (Fig. 5, a and b) show that microsilica, although very tiny, less than $1 \mu\text{m}$ (Fig. 5, a), bind firmly together into agglomerates of the size of cement particles (Fig. 5, b). Therefore it is very important

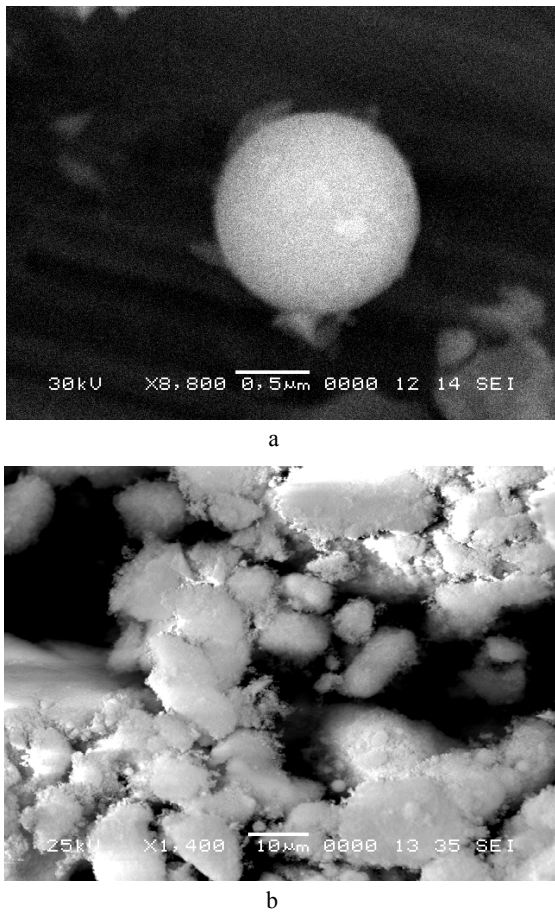

Fig. 5. Microphotographs: microsilica particle (a) and dried microsilica suspension (b)

to use a proper method of mixing microsilica to avoid formation of such agglomerates in the cement slurry. For this reason, during the research, microsilica was mixed in the form of suspension. The microphotographs also show that microsilica is of ideal spherical form (Fig. 5, a), which has a great influence on rheological properties of the slurry.

Fig. 6, a, illustrates the dependence of cement slurry (W/C = 0.55) with different dosage of microsilica suspension (replacing 3%–12% of the cement mass) yield stress on the additive content. The curve shows that due to the particle fineness microsilica suspension additive significantly increases yield stress of cement slurry when 3% to 12% of the cement mass is replaced by active dispersive additive.

Dependence of cement slurry (W/C = 0.55) with different dosage of microsilica suspension viscosity on the dosage of additive at the shear rate gradient 205 s^{-1} and 630 s^{-1} is presented in Fig. 6, b). The curves in this figure show that when 12% of the cement mass is replaced by microsilica suspension, the viscosity of cement slurry reduces both at low shear rate gradient (205 s^{-1}) and high rate gradient (630 s^{-1}).

Dependence of cement slurry (W/C = 0.55) with different dosage of microsilica suspension dilatancy ratios D and D_1 on the dosage of additive is presented in Fig. 7.

The curves in this figure show that the microsilica additive replacing up to 5% of the cement mass significantly reduces dilatancy of the cement slurry, while

bigger dosage of this additive has almost no effect on the dilatancy of the slurry. The significant drop of dilatancy of the cement slurry with microsilica additive may be explained by the fineness of additive particles compared to cement particles and spherical form of these particles (Fig. 5, a). The aforementioned factors reduce frictional force between cement particles in the slurry. The dosage of dispersive additive affecting the dilatancy of the slurry is up to 9% of the cement mass.

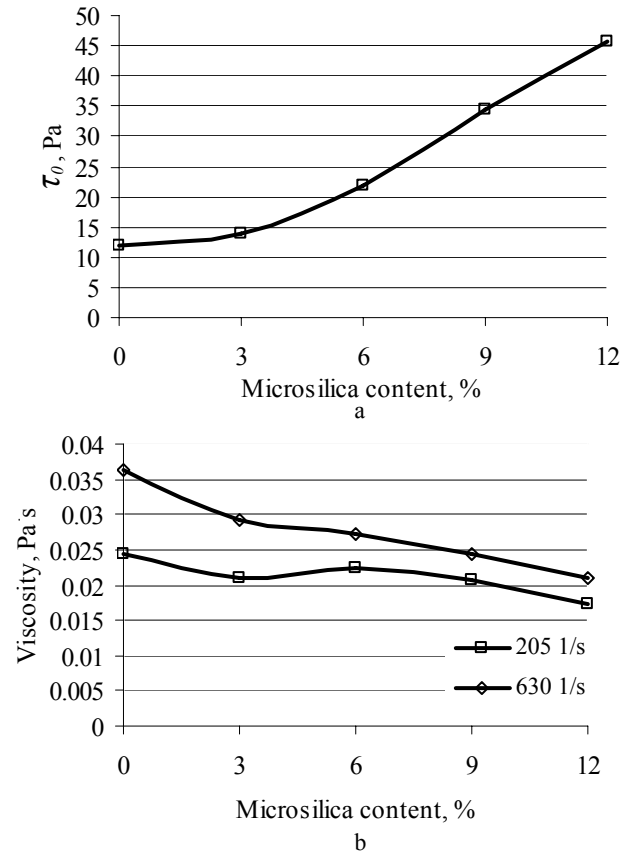

Fig. 6. Microsilica content effect on the yield stress (a) and viscosity (b) of Portland cement slurry at the shear rate gradient 205 s^{-1} and 630 s^{-1}

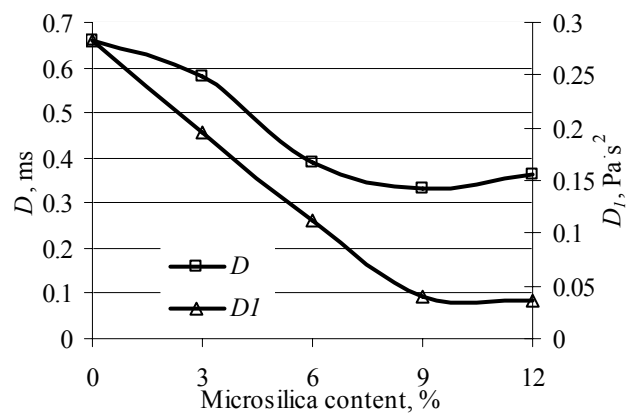

Fig. 7. Microsilica content effect on the dilatancy D and D_1 of the cement slurry

The flow curves of cement slurry (W/C = 0.55) with microsilica suspension (replacing 3%–12% of the ce-

ment mass) and the slurry with fixed dosage of plasticizers (0.6 % of cement mass) are different: cement slurry with microsilica suspension and PP superplasticizer have a more sloping curve compared to the cement slurry with microsilica suspension, plasticizer L and superplasticizer SNF; when 12 % of cement mass is replaced by active dispersive additive the flow curves of the slurry with plasticizer L and superplasticizer SNF almost correspond to the linear Bingham model. The flow curve of cement slurry without chemical admixture and with the biggest dosage of microsilica suspension corresponds to pseudo plastic fluid flow curve (Figure 3).

The dependence of cement slurry (W/C = 0.55) with fixed dosage of plasticizing admixtures (0.6 % of cement mass) yield stress on the dosage of microsilica suspension is presented in Fig. 8. This figure illustrates that with the increase of active dispersive additive in the slurry from 3 % to 12 % of the cement mass and with fixed dosage of plasticizing admixtures (0.6 % of cement mass) the yield stress of the slurry increases with plasticizer L and superplasticizer SNF, and almost does not change with superplasticizer PP. Microsilica suspension without chemical admixtures increases yield stress of cement slurry, when up to 12 % of cement mass is replaced by active diffusing admixture (Fig. 6, a).

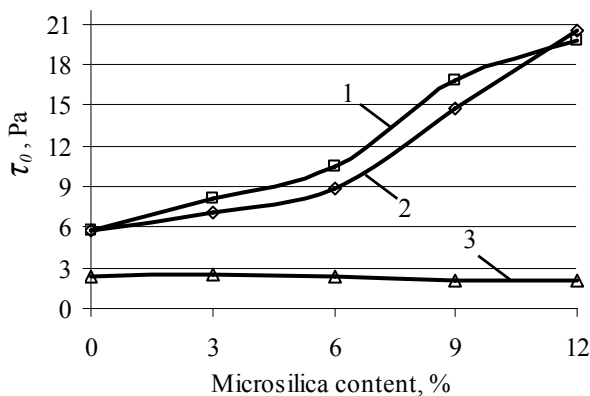

Fig. 8. Microsilica content effect on the yield stress of the cement slurry with the different plasticizing admixtures: 1 – with plasticizer L; 2 – with superplasticizer SNF; 3 – with superplasticizer PP

The dependence of cement slurry (W/C = 0.55) with fixed dosage of plasticizing admixtures (0.6 % of cement mass) viscosity on the dosage of microsilica suspension at the rate gradient 205 s^{-1} (a) and 630 s^{-1} (b) is illustrated in Fig. 9. The curves in this figure show that, with the increase of active dispersive additive dosage from 3 % to 12 % of cement mass and unchanging dosage of plasticizing admixtures (0.6 % of cement mass), viscosity of the slurry at lower rate gradient goes up with plasticizer L and goes down with superplasticizer SNF and superplasticizer PP. At higher rate gradient viscosity of the cement slurry with all plasticizing admixtures goes down (Fig. 9, b) if the dosage of microsilica suspension is increased. This proves that microsilica used together with plasticizing admixtures reduces dilatancy of cement slurries.

The increase of cement slurry with plasticizing admixtures viscosity with the increase of active dispersive

additive dosage may be explained by the adsorption of plasticizing admixture on the surface of cement or SiO_2 particles, i.e. lower content of the admixture in liquid phase and increased surface tension of the fluid. The effect of microsilica on the surface tension of plasticizing admixture solutions is illustrated in Fig. 10, a). Suspension composition is as follows: 3 grams of microsilica, 1 ml of plasticizing admixture and 10 ml of distilled water.

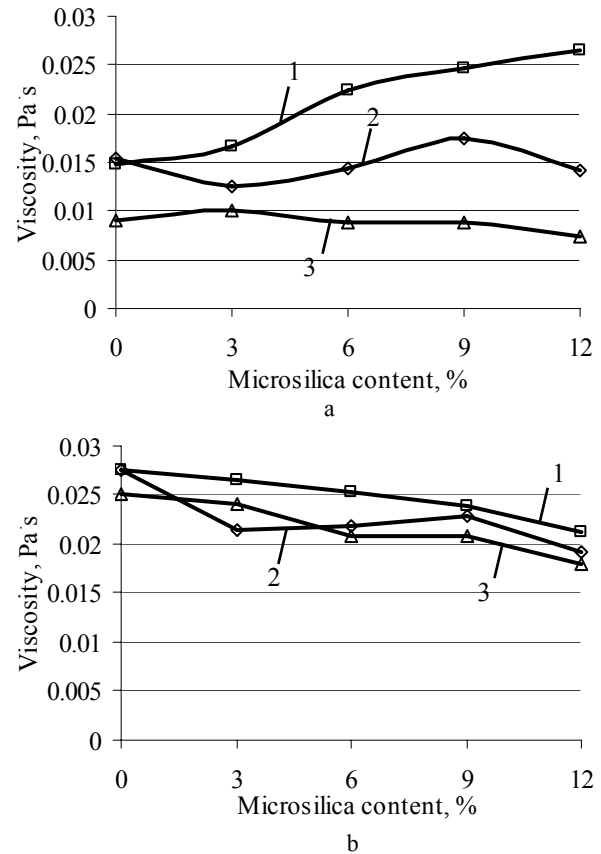

Fig. 9. Microsilica content effect on the viscosity of the cement slurry at different shear rates 205 s^{-1} (a) and 630 s^{-1} (b) and with different plasticizing admixtures: 1 – with plasticizer L; 2 – with superplasticizer SNF; 3 – with superplasticizer PP

The total effect of microsilica and cement on the surface tension plasticizing admixture solutions is illustrated in Fig. 10, b). Suspension composition is the following: 3 grams of cement, 1 gram of microsilica, 1 ml of plasticizing admixture and 10 ml of distilled water. The total effect of microsilica and cement on the surface tension plasticizing admixture solutions is slightly bigger than the effect of microsilica alone (Fig. 9, a). Surface tension of cement and active dispersive additive (SiO_2) suspensions increase as a result of plasticizing admixture adsorption on the surface of cement or SiO_2 particles, i.e. the reduced content of plasticizing admixture in liquid phase. Surface tension of cement and microsilica suspensions increases with time. When high strength hardened cement paste with active dispersive additives is produced effective plasticizing admixtures must be used because plasticizing effect reduces when molecules of the plasticizing agent adsorb on the surface of microsilica.

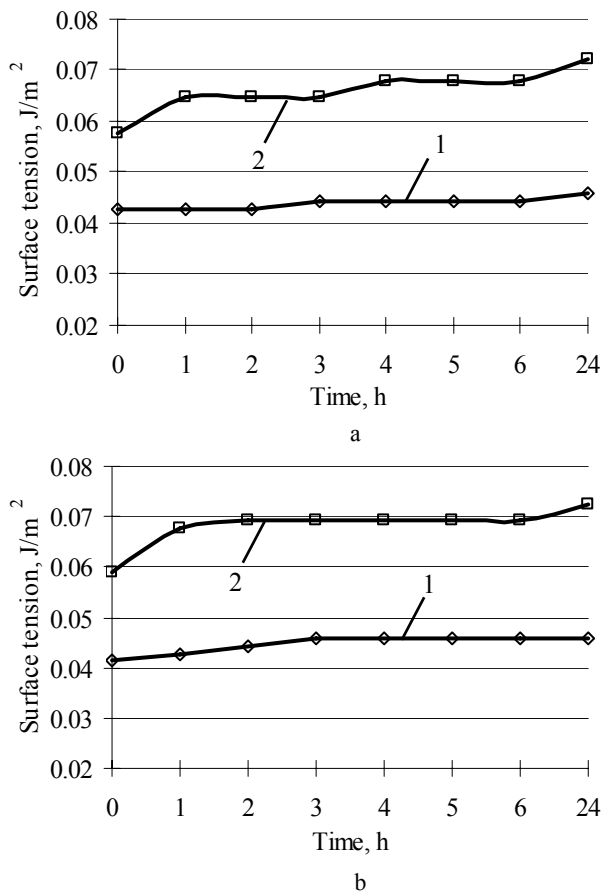

Fig. 10. Time effect on the surface tension of the microsilica additive (a) and cement and microsilica additive (b) with different plasticizing admixtures: 1 – with superplasticizer PP; 2 – with superplasticizer SNF

The dependence of cement slurry (W/C = 0.55) with fixed dosage of plasticizing admixtures (0.6 % of cement mass) dilatancy ratios D and D_1 on the dosage of microsilica suspension is illustrated in Fig. 11. This figure illustrates that, with the increase of active dispersive additive dosage replacing from 3 % to 12 % of cement mass and with a fixed dosage of plasticizing admixtures (0.6 % of cement mass), slurry dilatancy ratios D and D_1 drop down with plasticizer L and superplasticizer SNF, and remain almost unchanged with superplasticizer PP. Superplasticizer PP has a greater effect on cement slurry dilatancy than the dosage of active dispersive additive. Microsilica suspension without chemical agents significantly reduces cement slurry dilatancy when up to 12 % of cement mass is replaced with active dispersive additive (Fig. 7).

The type of cement slurry (W/C = 0.55) with fixed dosage of microsilica suspension (replacing 9 % of cement mass) and different dosage of plasticizing admixtures (0.2 %–1.0 % of cement mass), irrespective of their chemical composition, flow curves are close to the flow curve of dilatant fluids: the flow curve of cement slurry (9 % of cement mass replaced with microsilica suspension) without chemical agent corresponds to the linear Bingham model; flow curves of cement slurry with fixed dosage of microsilica suspension and different dosage of superplasticizer PP are more sloped compared to the flow curves of

cement slurry (9 % of cement mass replaced) with different dosage of plasticizer L and superplasticizer SNF. Superplasticizer PP has a greater effect on cement slurry dilatancy than the dosage of active dispersive additive.

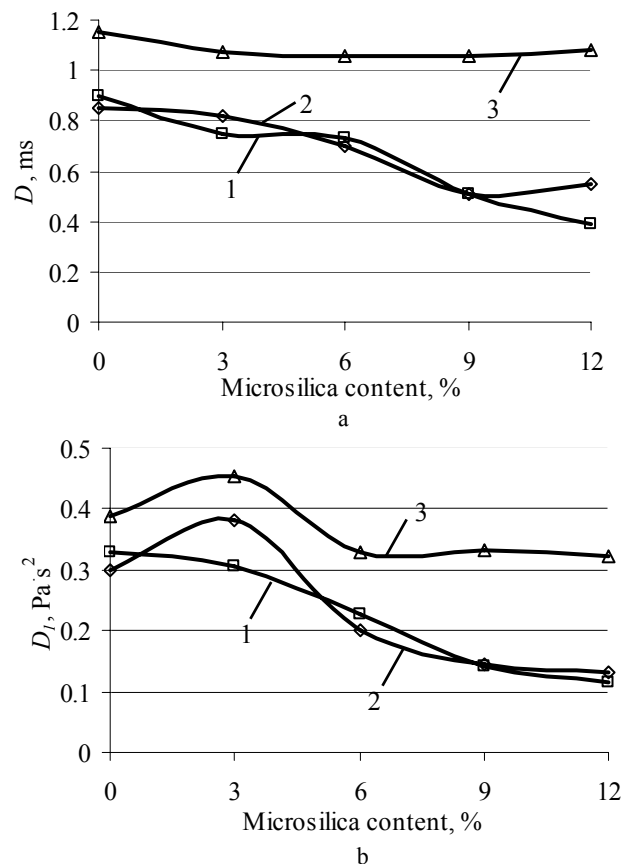

Fig. 11. Microsilica content effect on the dilatancy D (a) and D_1 (b) of cement slurry with different plasticizing admixtures: 1 – with plasticizer L; 2 – with superplasticizer SNF; 3 – with superplasticizer PP

The dependence of cement slurry (W/C = 0.55) with fixed dosage of microsilica suspension (9 % of cement mass replaced) yield stress on different plasticizing admixtures is illustrated in Fig. 12.

This figure illustrates that, with the increase of the dosage of plasticizing admixtures from 0.2 % to 1.0 % of cement mass and having the same dosage of microsilica suspension (9 % of cement mass), yield stress of the slurry goes down irrespective of the chemical composition of plasticizing admixture. The greatest drop in cement slurry yield stress was noticed with superplasticizer PP, less significant drop occurred with plasticizer L and superplasticizer SNF. Microsilica suspension without chemical agents increases cement slurry yield stress when 9 % of cement mass is replaced with active dispersive additive (Fig. 6, a).

The dependence of cement slurry (W/C = 0.55) with fixed dosage of microsilica suspension (replacing 9 % of cement mass) viscosity on different dosage of plasticizing admixtures at rate gradients 205 s⁻¹ (a) and 630 s⁻¹ (b) is illustrated in Fig. 13.

Curves in this figure illustrate that with the increase of the dosage of plasticizing admixtures (irrespective of their chemical composition) in the slurry from 0.2 % to 1.0 % of cement mass and having a fixed dosage of microsilica

suspension (replacing 9 % of cement mass) viscosity of the slurry goes down both at high and low rate gradient.

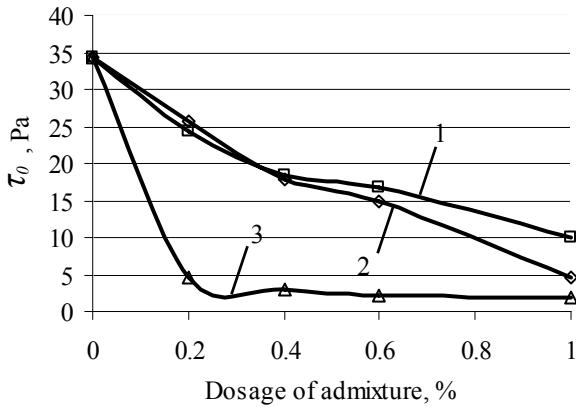

Fig. 12. Plasticizing admixtures dosage effect on the yield stress of the cement slurry with fixed dosage of microsilica and different admixtures: 1 – with plasticizer L; 2 – with superplasticizer SNF; 3 – with superplasticizer PP

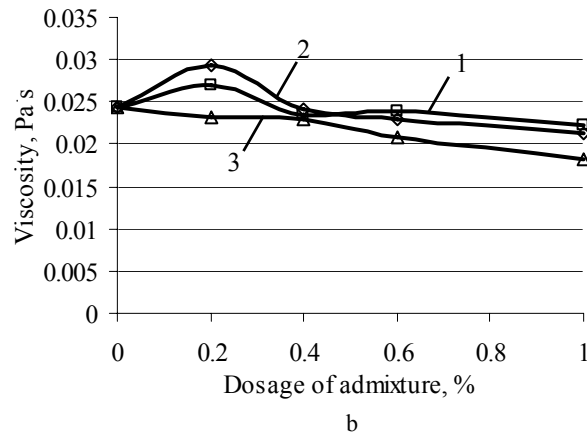
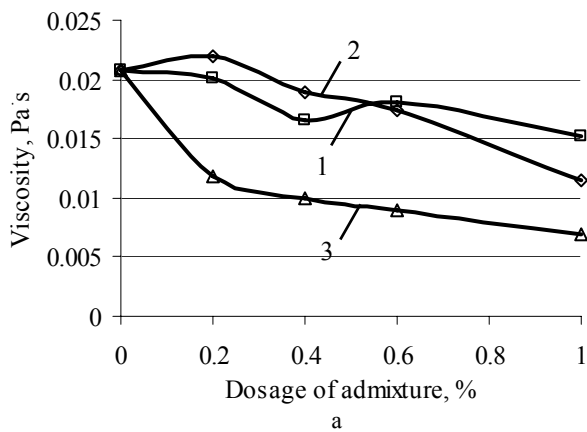

Fig. 13. Plasticizing admixtures dosage effect on the viscosity of the cement slurry with fixed dosage of microsilica at different shear rates 205 s^{-1} (a) and 630 s^{-1} (b) and different admixtures: 1 – with plasticizer L; 2 – with superplasticizer SNF; 3 – with superplasticizer PP

Dependence of cement slurry ($W/C = 0.55$) with fixed dosage of microsilica suspension (replacing 9 % of cement mass) dilatancy ratios D and D_1 on different dosage of plasticizing admixtures is illustrated in Fig. 14.

Plasticizing admixtures increase dilatancy of the slurry. Curves in Fig. 14 illustrate that with the increase of

plasticizing admixture dosage in cement slurry from 0.2 % to 1.0 % of cement mass and with fixed dosage of microsilica suspension (9 % of cement mass), dilatancy ratios D and D_1 are the highest in the slurry with superplasticizer PP, and lower in slurries with superplasticizer SNF and with plasticizer L.

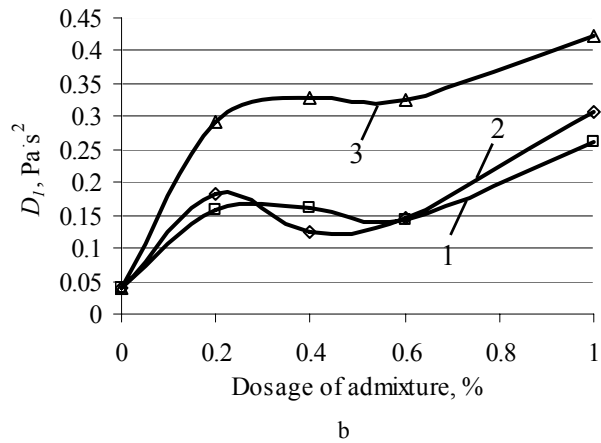
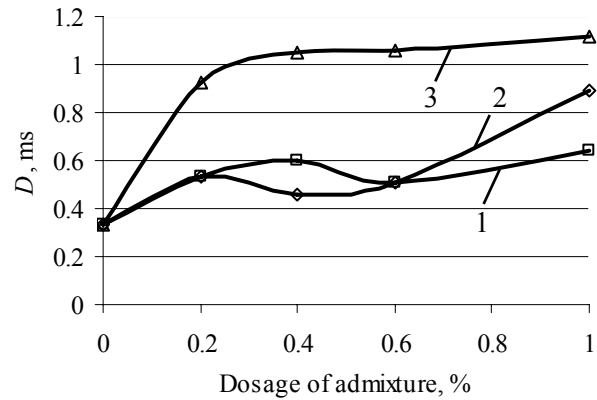

Fig. 14. Plasticizing admixtures dosage effect on the dilatancy D (a) and D_1 (b) of the cement slurry with different admixtures: 1 – with plasticizer L; 2 – with superplasticizer SNF; 3 – with superplasticizer PP

CONCLUSIONS

1. Microsilica additive increases yield stresses of cement slurry and reduces its viscosity with the increases microsilica content in the slurry.
2. Dispersive additives content up to 5 % of cement mass has the greatest effect on the cement slurry dilatancy.
3. Microsilica additive greatly reduces dilatancy of cement slurry due to its particles fineness and its spherical shape.
4. In the cement suspensions with active dispersive additive (microsilica) due to adsorption of plasticizing admixture on the cement or microsilica particles, i. e. its content reduction in the liquid phase, the yield stress of suspension increases and the cement slurry dilatancy decreases.
5. In the cement suspensions with dispersive additive and plasticizing admixtures surface tension in a period of time increases and the plasticizing effect decreases.

6. Microsilica suspension (replacing 3 %–12 % of cement mass) with the complexisnely used with plasticizing admixture has different effect on the dilatancy of cement paste: with superplasticizer based on polycarboxyl polymers increases, with superplasticizer based on naphthalenformaldehyde resin or plasticizer based on lignosulphonates – reduces.

REFERENCES

1. **Skripkiūnas, G., Daukšys, M.** Investigation of Rheological Properties and Dilatancy of Cement Slurries, Concrete and Reinforced Concrete *Conference Proceedings Technologija, Kaunas, 2003*: pp. 28 – 35 (in Lithuanian).
2. **Daukšys, M.** Influence of Cement Type on Rheological Properties of Cement Slurries *Advanced Materials and Technologies, Book of Abstracts of the 5-th International Summer School-Conference Technologija, Kaunas, 2003*: p. 31.
3. **Skripkiūnas, G., Daukšys, M.** Dilatancy of Cement Slurries With Chemical Admixtures *Journal of Civil Engineering and Management* 10 (3) 2004: pp. 227 – 233.
4. **Hu, C., De Larrard, F.** The Rheology of High-Performance Concrete *Cement and Concrete Research* 26 (2) 1996: pp. 283 – 294.
5. **Khayat, K. H., Saric-Coric, M., Liotta, F.** Influence of Thixotropy on Stability Characteristics of Cement Grout and Concrete *ACI Materials Journal* 99 (3) 2002: pp. 234 – 241.
6. **De Larrard, F., Hu, C., Sedran, T., Szitkar, J. C., Joly, M., Claux, F., Derkx, F.** A New Rheometer for Soft-to-Fluid Fresh Concrete *ACI Materials Journal* 94 (3) 1997: pp. 234 – 243.
7. **Kluge, S.** Dilatant Sand. <http://epod.usra.edu/archive/epodviewer.php3?oid=162656>.
8. **Rosenberg, B. L.** Osborne Reynolds' Submechanics of the Universe: a Structured Context for: Matter, Energy, Space, Time and PSI Phenomena. Presented at the Atlantic University, Atlantic City, 1989: p. 11.
9. **Reiner, M.** Deformation Strain and Flow. An Elementary Introduction to Rheology. London. 1960: p. 381.
10. **Pivinskij, J. E.** Theoretical Aspects of Ceramic and Refractors. Sankt-Peterburg, Strojizdat, 2003: pp. 43 – 106 (in Russian).
11. **Zhang, X., Han, J.** The Effect of Ultra-Fine Admixtures on the Rheological Property of Cement Paste *Cement and Concrete Research* 30 (5) 2000: pp. 827 – 830.
12. **Ferraris, Ch. F., Obla, K. H., Hill, R.** The Influence of Mineral Admixtures on the Rheology of Cement Paste and Concrete *Cement and Concrete Research* 31 (2) 2001: pp. 245 – 255.
13. **Curcio, F., DeAngelis, B. A.** Dilatant Behavior of Superplasticized Cement Pastes Containing Metakaolin *Cement and Concrete Research* 28 (5) 1998: pp. 629 – 634.
14. **Cyr, M., Legrand, C., Mouret, M.** Study of the Shear Thickening Effect of Superplasticizers on the Rheological Behaviour of Cement Pastes Containing or not Mineral Additives *Cement and Concrete Research* 30 (5) 2000: pp. 1477 – 1483.
15. **Sasnauskas, K., Skripkiūnas, G.** Interaction of Water and Solid Disperse Phase in Buildings Materials *Chemical Technology* 21 (4) 2001: pp. 25 – 30 (in Lithuanian).
16. **Gallias, J. L., Kara-Ali, R., Bigas, J. P.** The Effect of Fine Mineral Admixtures on Water Requirement of Cement Pastes *Cement and Concrete Research* 30 (10) 2000: pp. 1543 – 1549.
17. **Sicker, A., Huhn, H-J.** Dependence of Rheological Properties of Mortars on the Ambient Temperature *LACER* 3 1998: pp. 101 – 108.

