

Cu-Al-O system: Catalytic Coatings Obtained by the Activated Thermo-Chemical Condensate Deposition Method

Kazys BABILIUS, Artūras BABILIUS*

Department of Manufacturing Technologies, Kaunas University of Technology, Kęstučio 27, LT-44025 Kaunas, Lithuania

Received 16 May 2007; accepted 06 January 2008

Cu-Al-O type catalytic coatings of controlled thickness were obtained by the activated thermo-chemical condensate deposition method (AT-CCD), without formation of metal underlayer, straight on the strip steel OC-404 of 40 μm thickness, which temperature did not exceed 250 $^{\circ}\text{C}$ during coating formation.

After thermal treatment, following investigations of the system “coating-substrate” were made: adhesion, resistance to chemical effect in acids, phase composition, size of crystallites, morphology and elemental composition of the surface.

Given catalyst assessment temperature up to 275 $^{\circ}\text{C}$, relatively small gas flows $Q_{\text{gas}} = 0.5$ l/min and large oxygen amount $\text{O}_2 = 20\%$, the catalyst (CO oxidation) begins to operate at $T_5 = 75$ $^{\circ}\text{C}$, reaches 50 % conversion at $T_{50} = 140$ $^{\circ}\text{C}$, and maximum conversion is obtained at 250 $^{\circ}\text{C}$.

Given catalyst assessment temperature up to 600 $^{\circ}\text{C}$, relatively big gas flows $Q_{\text{gas}} = 2.75$ l/min and small oxygen amount $\text{O}_2 = 0.2\%$, the catalyst begins to operate at $T_5 = 220$ $^{\circ}\text{C}$, reaches 50 % conversion at $T_{50} = 300$ $^{\circ}\text{C}$. Maximum conversion – CO = 92 % and $\text{NO}_x = 100\%$ – is obtained at 400 $^{\circ}\text{C}$.

Keywords: coatings, nanocrystalline, Cu-Al-O, $\gamma\text{-Al}_2\text{O}_3$, adhesion, resistance to acids, morphology, X-ray diffraction, crystallite size, CO and NO catalysts.

1. INTRODUCTION

Carbon monoxide (CO) plays the major role in tropospheric hydroxyl radical reactions and hence has a big influence on the oxidizing capacity of the atmosphere as well as on the concentrations of other trace gases. Further, atmospheric CO reflects the effects of human activity on atmosphere since fossil fuel combustion is one of its representative sources [1].

The role of the catalytic converters is to oxidize hydrocarbons and carbon monoxide, and to reduce oxides of nitrogen present in the engine exhaust gas. The converter is usually a monolith honey-comb with either a ceramic or metal substrate, containing several thousands of parallel channels. The channel walls are coated with a thin wash-coat of alumina, which serves as a support for the noble metal catalyst (platinum, palladium, rhodium), the later being added as an oxygen storage agent [2].

Ceramic substrates are based on cordierite ($2\text{MgO}\cdot 2\text{Al}_2\text{O}_3\cdot 5\text{SiO}_2$). Substrates derived from ultra thin foils of corrosion-resistant steels came onto the market in the late 1970s. In the beginning the foils were made from material 0.05 mm thick, allowing high cell densities to be achieved and complex internal structures could be developed. Today, substrates with wall thickness down to 0.025 mm and cell densities of 1000 cpsi and 1200 cpsi (cells per square inch) are available.

Progress in ceramic and metal substrate technology has brought big advantages. A large catalysts surface area can be incorporated into a given converter volume and this allows better conversion efficiency and durability. The thin walls reduce thermal capacity and avoid the penalty of increased pressure losses.

The empirical knowledge of catalysis and catalysts is enormous. It is known, for instance, that Pd and Pt-Rh are the best exhaust catalysts for NO removal, while Co, Fe and Ru are best Fischer-Tropsch catalysts, Pt, Pd and Ag are best oxidation catalysts, and Ru and Fe are the best ammonia synthesis catalysts [3].

In automotive exhaust emission control, to meet strict environmental regulations, the complete oxidation of carbon monoxide is of prime importance. Precious metals have long been used as the most efficient CO oxidation catalysts with high activity and stability. Due to the cost and limited availability of precious metals, considerable attention has been paid to transition metals and their oxides as substitute catalysts, e.g. copper [4].

The photocatalytic ability of CuM_2O_4 (Al, Cr, Mn, Fe and Co) crystallizing with spinel-type structure has been evaluated according to the H_2 – evolution. The oxides are black and display a semi-conductive behaviour where the electronic balance comes from a small over stoichiometry ($\text{CuCo}_2\text{O}_{4.016}$) [5].

CuO is used as a catalysts or catalysts precursor in many chemical reactions that involve hydrogen as a reactant or a product: methanol synthesis from CO ($\text{CO} + 2\text{H}_2 \rightarrow \text{CH}_3\text{OH}$) or CO_2 ($\text{CO}_2 + 3\text{H}_2 \rightarrow \text{CH}_3\text{OH} + \text{H}_2\text{O}$), the water-gas shift reaction ($\text{CO} + \text{H}_2\text{O} \rightarrow \text{CO}_2 + \text{H}_2$), methanol steam reforming ($\text{CH}_3\text{OH} + \text{H}_2\text{O} \rightarrow \text{CO}_2 + 3\text{H}_2$), oxidative methanol reforming ($\text{CH}_3\text{OH} + \frac{1}{4}\text{O}_2 + \frac{1}{2}\text{H}_2\text{O} \rightarrow \text{CO}_2 + \frac{5}{2}\text{H}_2$), NO reduction ($\text{NO} + \text{H}_2 \rightarrow \frac{1}{2}\text{N}_2 + \text{H}_2\text{O}$), etc. It has been proposed that in several catalytic processes CuO undergoes a complete reduction and metallic copper or Cu^0 is the real active phase [6].

Oxide coatings on metal surfaces are a cheap and perspective way to save material resources. There are many ways for coating formation, including diffusive,

*Corresponding author. Tel.: +370-687-48719; fax.: +370-37-455575.
E-mail address: arturasbabilius@gmail.com (A. Babilius)

PVD, CVD, thermal spray, electrochemical etc. [7]. The main part in the system “material-operating environment” is a surface layer of material that must have stable characteristics during time [8].

Without above mentioned ways, catalytic oxide coatings can be obtained by the activated thermo-chemical condensate deposition method, too [9].

The aim of the work is to make following investigations of the coatings obtained by the activated thermo-chemical condensate deposition method (system Cu-Al-O): adhesion, resistance to long-term chemical effect in acids, phase composition, size of crystallites, morphology and chemical composition; to make catalytic investigations of the coatings obtained from system Cu-Al-O, in order to find conversion of coal monoxide and, in particular case, of nitrogen oxides.

2. EXPERIMENTAL

Catalytic coating (system Cu-Al-O) of 25 micrometers thickness was obtained individually from both side on the substrate (strip steel OC-404) of 40 micrometers thickness.

A substrate is made of such metal or metal alloy which, being heated not less than 25 % above the operating catalyst temperature, does not make steam condensate phase of catalytic centres depositing on the catalyst surface, from the chemical elements, combinations of which block or deactivate catalytic carrier and catalytically active phases. A metal substrate and an oxide coating are connected to each other by adequate adhesive – cohesive connections at the interfaces during formation of an oxide coating, without use of special treatment of the substrate surface and without formation of a metal underlayer.

A catalytic coating, participating in catalytic reactions, is resistant at the same time thermally, mechanically, and chemically to operating environment, and it operates reliably under the conditions of a thermal shock. The coating has a stationary, statistically with little change in inwards volume, elemental chemical composition.

The necessary features of interconnections of the coating characteristics: density of defects in a catalytic coating, non-homogeneous surface layer, combination of separation lines between different oxide phases, some defined surface activation energies. A catalytic coating, in a wide temperature range, has a big own surface area, mesopores of defined size, and existing phases have crystallites of defined size. A catalytic system operates well in the oxidation-reduction reactions, has a good selectivity, relatively low burning temperature, a big degree of conversion.

Following investigations were made for the coated test pieces, with use of such methods and equipment:

1. For the thermal treatment of the system “coating – substrate” thermal furnace SNOL 1.6.1-11 was used. Test pieces were thermally treated at 12 different temperatures: 100 °C, 200 °C, 220 °C, 300 °C, 400 °C, 500 °C, 600 °C, 700 °C, 800 °C, 900 °C, 1000 °C, and 1100 °C. Test pieces were heated at a given temperature at the rate of 10 °C/min, held for 4 hours and cooled with a furnace.

2. Adhesion of the coatings was evaluated by the “scratch” method, – using a designed adhesion tester [9];

3. Tests of resistance to long-term chemical effect in 20 % solutions of acid HCl and HNO₃ mixture (ratio 3:1)

were made using standard chemical equipment and technically clean reagents.

4. Surface morphology and elemental composition of the coatings were investigated by SEM-EVO 50. Detector INCA_x was used for the EDS.

5. Phase composition of the coating (XRD) was made with an X-ray device DRON-6, using PDF-2 database [10]. Crystallite size was evaluated with X-fit program [11].

6. Analysis of gases was made by gas analysers Ecoline 6000 and Testo 300.

7. A testing-bench of catalysts was used for catalytic tests (Fig. 1).

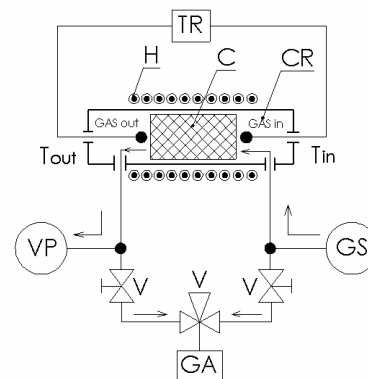

Fig. 1. A testing-bench of catalysts: TR – temperature regulator; H – heater; C – catalyst; CR – catalysts reactor; T – thermocouple; GS – gas source; V – valve; GA – gas analyser; VP – vacuum pump

A metal plate covered from both sides was corrugated, in order to make channels (air passages) during its further fixing into cylinder-shaped roll (catalytic block) (Fig. 2).

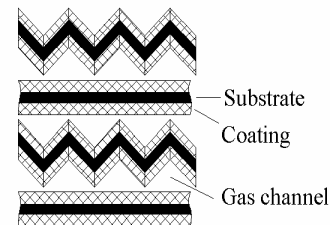

Fig. 2. Structure of catalytic block

Catalytic blocks length in both cases were $L = 100$ mm, whereas diameters differs: a – $D = 15$ mm and b – $D = 40$ mm. Total geometric area of a catalytic wall (S), as well as volume (V) and test conditions of a block are following:

a) Block-D15: $S_{15} = 0.12 \text{ m}^2$; $V_{15} = 18 \text{ cm}^3$. Gas parameters before blocks: $\text{O}_2 = 20 \%$, $\text{CO} = 50 \text{ ppm} - 4000 \text{ ppm}$, $\text{NO}_x = 1 \text{ ppm} - 7 \text{ ppm}$, $\text{CO}_2 = 0.1 \% - 0.9 \%$, rate – $Q_g = 0.5 \text{ litres/min}$;

b) Block-D40: $S_{40} = 0.40 \text{ m}^2$; $V_{40} = 125 \text{ cm}^3$. Gas parameters before blocks: $\text{O}_2 = 0.15 \%$, $\text{CO} = 4000 \text{ ppm}$, $\text{NO}_x = 40 \text{ ppm}$, $\text{CO}_2 \sim 13 \%$, rate – $Q_g = 2.7 \text{ litres/min}$.

3. RESULTS AND DISCUSSIONS

3.1. Composition, morphology and mechanical properties of Cu-Al-O coatings

Measurements of adhesion (critical load in scratch testing) have shown that bonding of a coating of test

pieces, thermally treated up to 500 °C temperature, to a substrate is increasing gradually and practically remains stable up to 700 °C, when critical load in scratch testing is equal to 27 N–28 N (Fig. 3). Critical load of the test pieces, thermally treated at higher temperatures, is increasing remarkably and becomes equal to 47 N at 1100 °C.

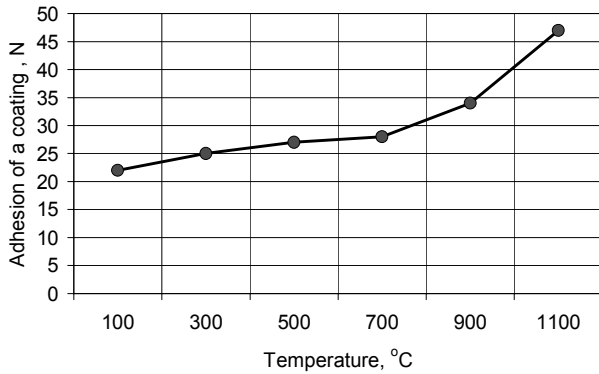

Fig. 3. Critical load of Cu-Al-O coating in scratch testing depending on thermal treatment temperature

Evaluation of chemical stability of the samples in 20 % solution of acids HCl and HNO₃ (ratio 3:1) had an effect first of all (after 17–20 hours) on the test pieces thermally treated up to 500 °C temperature (Fig. 4). Disintegration time for the test pieces thermally treated at higher temperatures, changed exponentially and reached 123 hours at 1100 °C.

For a comparison, the solution completely destroys a substrate without a coating after 4–6 hours. That occurs due to deposited ceramic layer on the substrate and diffusion processes in the system „coating – substrate“ by increasing thermal treatment temperature.

According to the XRD analysis the formation of “coating – substrate” (Cu-Al-O system – steel OC-404) has six dominating phases in the temperature range of 100 °C–1100 °C: substrate’s metal phase Fe-Cr and oxide phases:

γ -Al₂O₃, CuO, CuAl₂O₄, α -Al₂O₃, CuAlO₂ (Fig. 5). Crystallites of metal phase Fe-Cr of the substrate are increasing gradually from 23 nm to 181 nm at temperatures (200 °C–800 °C). At higher temperatures this intensity of the peak corresponding to this phase decreases to the level of noise.

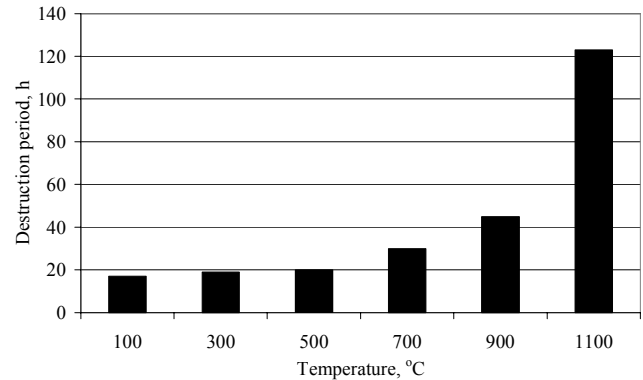

Fig. 4. Resistance of the system “coating-substrate” to 20 % acids HCl and HNO₃ (ratio 3:1)

γ -Al₂O₃ phase of a catalytic carrier remains up to 1100 °C, and crystallite size reaches up to 44 nm (Fig. 6). At temperature range of 100 °C–800 °C, there is a stable nanocrystal γ -Al₂O₃ phase with a big surface area and crystallite size 5.8 nm–13.1 nm. Crystallite size of the catalytically active phase CuO varies from 15.6 nm to 22.5 nm at the temperature range of 100 °C–700 °C. When temperature is increased up to 900 °C, crystallites of CuO phase are increasing, reach the size of 65 nm and finally their phase disappears in the XRD pattern. Dark coloured, light absorbing spinel phase CuAl₂O₄ exists at temperature range of 800 °C–1100 °C, when crystallites are increasing from 14 nm to 48 nm. Corundum, α -Al₂O₃ phase, appears at 900 °C temperature, crystallite size increases from 38 nm to 97 nm, having reached 1100 °C temperature.

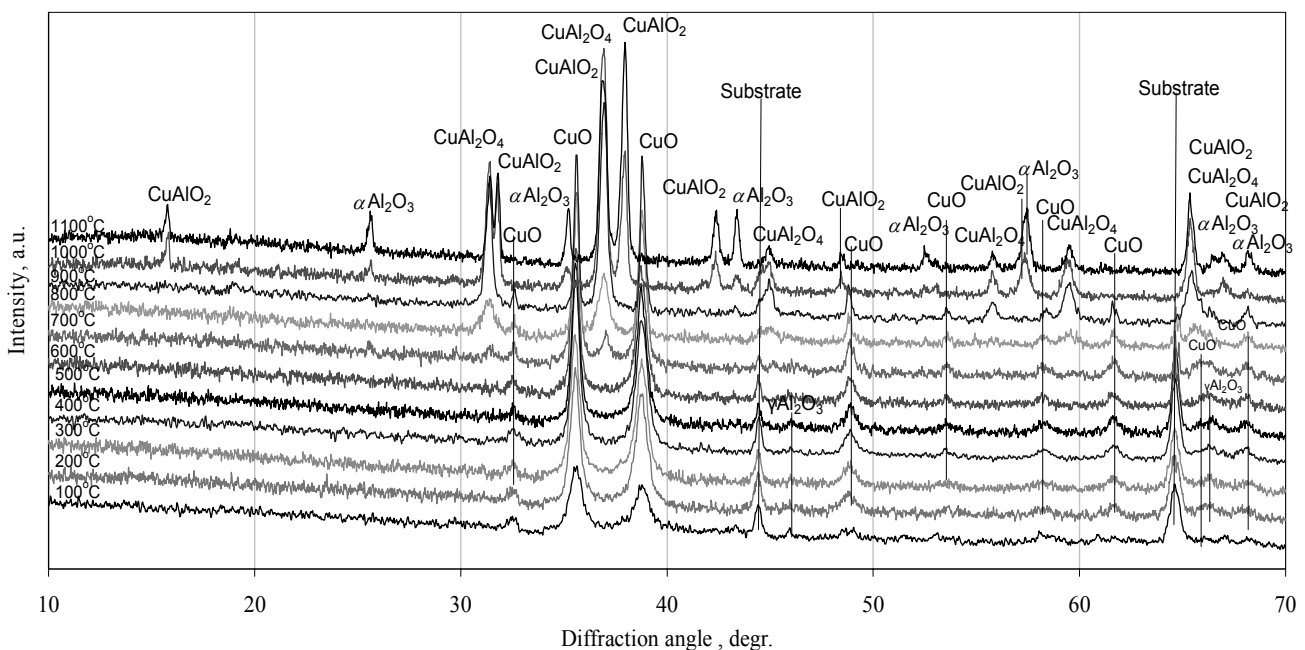

Fig. 5. X-ray diffraction patterns of a system “coating – substrate”

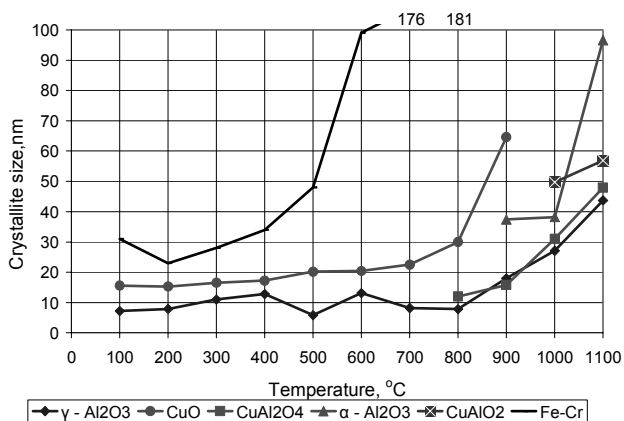

Fig. 6. Crystallite size distribution of system “coating – substrate”

SEM picture (Fig. 7) illustrates morphology of the coating that is typical only system Cu-Al-O. One can clearly identify, according to the shape, phases dominating at 700 °C: γ -Al₂O₃ and CuO.

This coating has many structural defects, as well as surface relief of variable shape, where height difference between separate elements of the coating can reach up to 1/3 of the coating width.

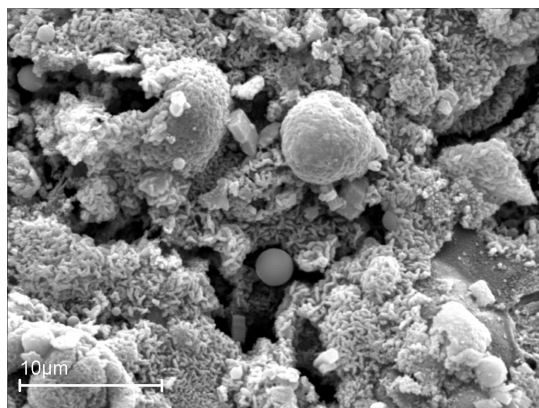

Fig. 7. Morphology of a Cu-Al-O coating on a steel OC-404 plate after heat treatment 700 °C

It means that the most catalytically active phase, being formed of Cu and partly of O atoms, makes the major part of coating surface. Chemical composition of the coating surface in the area of 10 μm²–50 μm² measured at the same

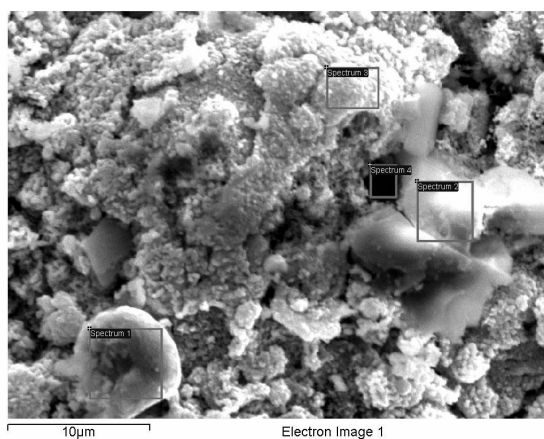

Fig. 8. EDS spectra of coating surface at different location (1, 2, 3, 4)

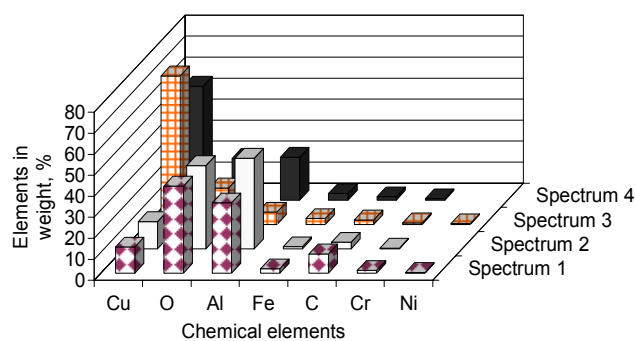

Fig. 9. The distribution of elemental chemical composition at different locations of coating

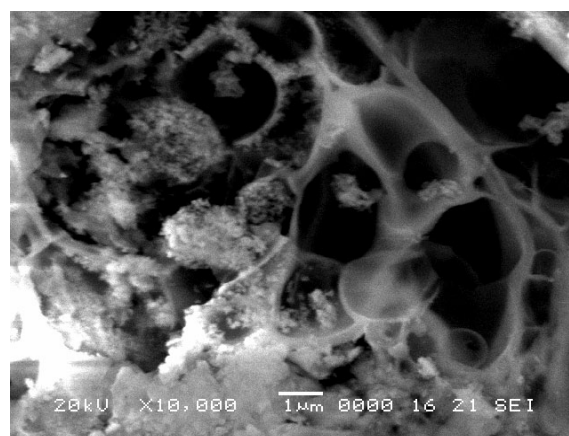

Fig. 10. CuO phase, built into a catalytic carrier frame

time (Fig. 8) showed the variation of chemical composition of the separate spectra (Fig. 9). Coating surface consists of many different, appropriately situated phases. Increasing magnification, enables to detect fragments of catalytically active CuO phase, built into a catalytic carrier frame, as it can be seen in Fig. 10.

3.2 Catalytic tests

3.2.1. CO conversion at relatively small gas flows and large amount of oxygen (block D-15)

In this experiment, catalytic blocks were thermally treated at the discrete temperatures: 220 °C, 300 °C, 400 °C, 500 °C, 600 °C, 700 °C, 800 °C, 900 °C, and 1000 °C. Afterwards, when catalysts were assessed at 275 °C, maximum of CO conversion was found (Fig. 11). As shown, the best result is achieved during thermal treatment at 300 °C temperature when 100 % conversion is achieved. Good operation is noticed as well for the catalysts treated up to 800 °C.

Catalysts were both treated for different time (4 h, 24 h, 48 h) at the same temperature – 600 °C = const. and investigated in a testing-bench of catalysts, increasing temperature up to 275 °C (Fig. 12). The best (lowest) ignition temperature – $T_5 = 65$ °C was shown by the catalyst thermally treated for 48 h but it had the smallest maximum conversion – 87 %. The worst (highest) ignition temperature – $T_5 = 100$ °C was shown by the catalyst thermally treated for 24 h but it had the highest maximum conversion – 96 %.

When assessment of the catalyst thermally treated at 500 °C was made for 6 hours in a testing-bench of catalysts, with constant parameters: $T_{\text{test}} = 250\text{ °C}$, $\text{CO}_{\text{input}} = 150\text{ ppm} = \text{const}$, it appears that the catalyst enters stationary conditions after about 1.5 hours ($T_{\text{test}} = 250\text{ °C}$, $\text{CO}_{\text{input}} = 150\text{ ppm}$) (Fig. 13). Conversion decreases at this time more than 20 % and reaches 70 % value.

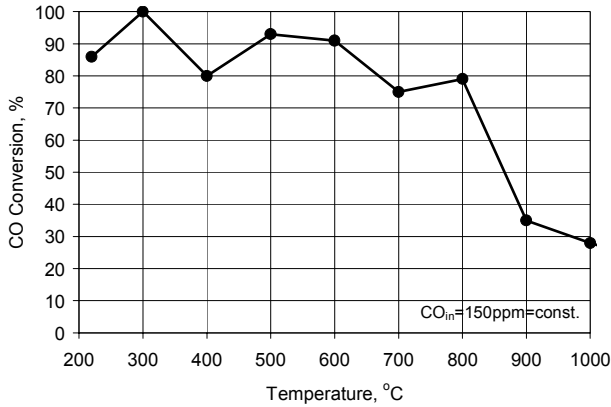

Fig. 11. Dependence of conversion catalyst on thermal treatment temperature

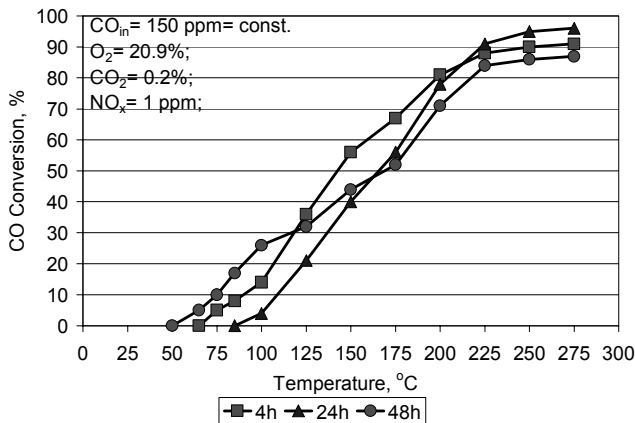

Fig. 12. Dependence of CO conversion on thermal treatment time of catalyst

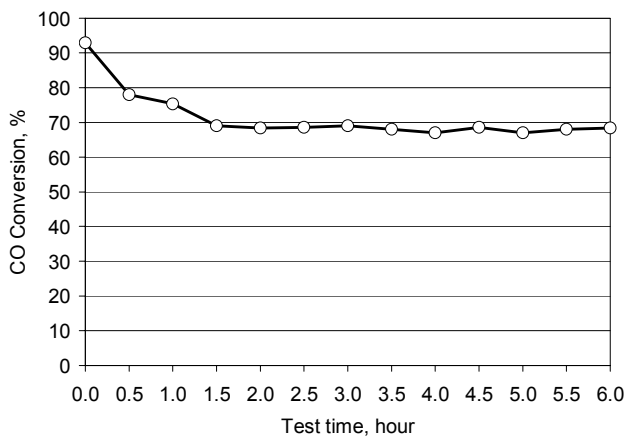

Fig. 13. Time - operation characteristic of catalyst

The catalytic block thermally treated at 300 °C – 4 h, in any of the three cycles, begins to convert CO to CO₂ at 50 °C (Fig. 14). Maximum conversion decreases from 100 % in the first catalytic cycle to 89 % in the second, and to 82 % in the third catalytic cycle.

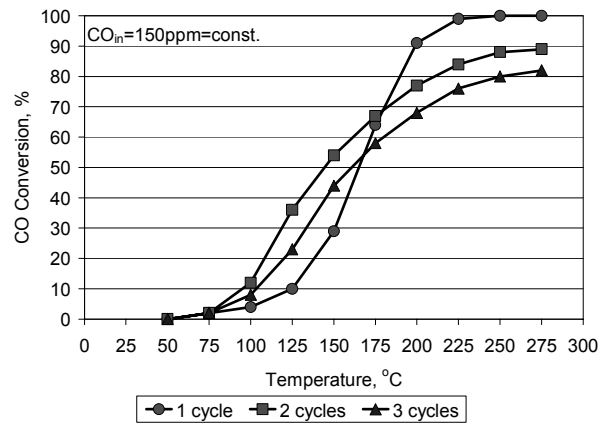

Fig. 14. Comparison of the CO conversion of three cycles

When influence of carbon monoxide amount to conversion is investigated, while temperature of a catalytic converter being increased up to 275 °C, relatively good operation of the catalyst at small CO ppm amounts is perceived (conversion at 50 ppm = 100 % and at 150 ppm = 93 %) (Fig. 15). When CO concentration in input of the catalytic converter is increasing, conversion decreases monotonously and reaches 50 % at 4000 ppm.

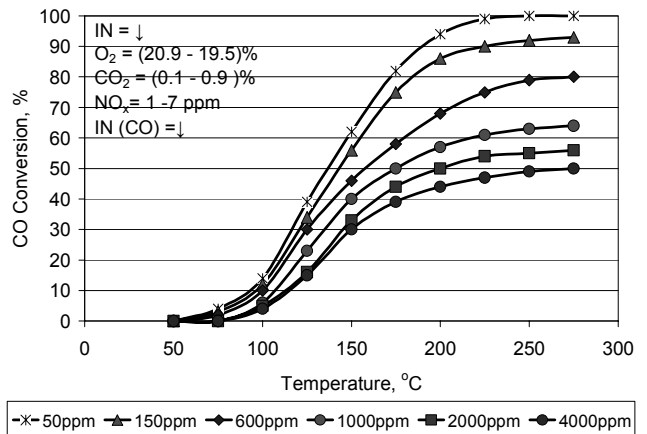

Fig. 15. Influence of CO ppm amount to conversion

When efficiency of CO conversion of the catalytic block at temperatures as low as possible is analysed according to 5, 25, 50, 75, and 100 % reached conversions, under different thermal treatment temperatures of catalytic blocks, variety of results is perceived (Fig. 16). The best

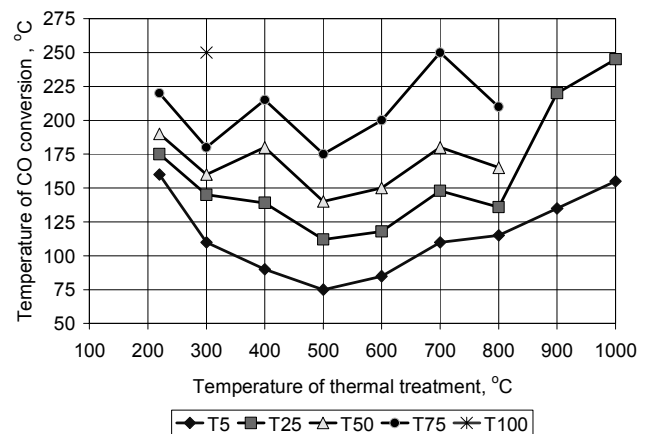

Fig. 16. Technological map of catalytic conversions

absolute result – 100 % conversion - is reached in only one case, for the catalytic block thermally treated at 300 °C temperature and tested at 250 °C. However, this catalytic block has higher conversion temperatures with 5, 25, and 50 % conversions than the catalytic blocks thermally treated at 500 °C temperature that are undoubtedly the best in point of view of practical application. The catalyst must not be heated above 800 °C in order to avoid significant decrease of conversion.

3.2.2. CO and NO_x conversion at relatively high gas flows and small amount of oxygen (block D-40)

In this experiment, catalytic blocks were thermally treated at 700 °C. Increasing assessment temperature of the catalytic block up to 600 °C, CO and NO_x conversion was investigated (Fig. 17).

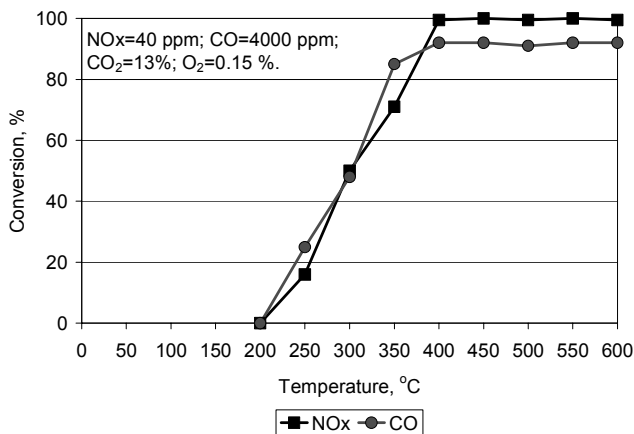

Fig. 17. Catalytic tests: block D-40. CO and NO_x conversion at relatively big gas flows and small amount of oxygen

During CO oxidation, the catalyst begins to operate at about $T_5 = 220$ °C, reaches 50 % conversion at $T_{50} = 300$ °C., maximum conversion – 92 % – is reached at 400 °C. At relatively small oxygen amount ($O_2 = 0.15$ %) catalyst quite enough reduce NO_x. It was found that during reduction of nitrogen oxides, the catalyst begins to operate and reaches maximum – 100 % – conversion at the same temperature.

4. CONCLUSIONS

1. Cu-Al-O type catalytic coating was obtained by the activated thermo-chemical condensate deposition method, without formation of metal underlayer, directly on a metal substrate, at 250 °C temperature.
2. Coating (system Cu-Al-O) – substrate (steel OC-404), at the temperature range of 100 °C–1100 °C, is resistant to 20 % solution of acids: HCl – HNO₃ (ratio 3:1). Critical load in the coating adhesion measurements increase from 22 N to 58 N by increasing thermal treatment temperature.
3. Under operating temperature conditions of the catalyst, up to 700 °C temperature, the coating has nanocrystalline γ -Al₂O₃ phase of a catalytic carrier, with crystallite size 5.8 nm–13.1 nm, and catalytically active – CuO – phase, with crystallite size increasing monotonously from 15.6 nm to 22.5 nm.

4. The coating has structural defects, as well as developed surface relief; approximate average of elemental chemical composition of the surface according: Cu – 60 % weight, Al – 12 % and O – 21 %.
5. Increasing of the catalyst assessment temperature to 275 °C, under relatively small gas flows $Q_{\text{gas}} = 0.5$ l/min and large amount of oxygen $O_2 = 20$ % (block D15), Cu-Al-O system operates well during CO oxidation with thermal treatment up to 800 °C temperature. The best thermal treatment temperature is 500 °C, and exposure 24 hours. The catalyst begins to operate at $T_5 = 75$ °C, it reaches 50 % conversion at $T_{50} = 140$ °C, and maximum conversion is obtained at 250 °C. The catalyst enters stationary operating conditions after 1.5 hours. With increase of CO concentration, conversion decreases.
6. Increase of catalyst assessment temperature up to 600 °C, under relatively big gas flows $Q_{\text{gas}} = 2.75$ l/min and small amount of oxygen $O_2 = 0.15$ % (block D-40) maximum conversion – CO = 92 % and NO_x = 100 % – is obtained at 400 °C.

REFERENCES

1. Tsunogai, U., Hachibu, Y., Komatsu, D., Nakagawa, F., Gamo, T., Akiyama K. An Updated Estimation of the Stable Carbon and Oxygen Isotopic Compositions of Automobile CO Emissions *Atmospheric Environment* 37 2003: pp. 4901 – 4910.
2. Mukadi, L. S., Hayes, R. E. Modeling the Three-way Catalytic Converter with Mechanistic Kinetics Using the Newton-Krylov Method on a Parallel Computer *Computers and Chemical Engineering* 26 2002: pp. 439 – 455.
3. Norskov, J. K., Bligaard, T., Lagodottir, A., Bahn, S., Hansen, L. B., Bollinger, M., Bengaard, H. Universality in Heterogeneous Catalysis *Journal of Catalysis* 209 2002: pp. 275 – 278.
4. Huang, T. N., Tsai, D. H CO Oxidation Behavior of Copper and Copper Oxides *Catalysis Letters* 87 (3 – 4) 2003.
5. Saadi, S., Bouguelia, A., Trari, M. Photoassisted Hydrogen Evolution Over Spinel CuM₂O₄ (Al, Cr, Mn, Fe and Co) *Renewable Energy* 31 2006: pp. 2245 – 2256.
6. Rodrigues, J.A., Kim, J.I., Hanson, J.C., Perez, M., Frenkel, A.I. Reduction of CuO in H₂: *in situ* time-resolved XRD studies *Catalysis Letters* 85 (3 – 4) 2003.
7. Hocking, M. G., Vasantaree, V., Sidky, P. S. Metallic and Ceramic Coatings. New York, 2000: p. 10.
8. Babilius, A. Formation of Tungsten Carbide Coatings in Thermal Spraying Methods. Dr. Sc. Thesis. Kaunas University of Technology, Kaunas, Lithuania, 2005.
9. Babilius, K., Babilius, A. Research of Coatings Obtained in the Activated Thermo-Chemical Condensate Deposition Method, Al-O System *Materials Science (Medžiagotyra)* 2 (8) 2006: pp. 114 – 119.
10. JSPDS Cards – International Center for Diffraction Data. 12 Campus Boulevard Newtown Square, PA 19073 – 3273 USA.
11. Cheary, R. W., Coelho, A. A. (1996). Programs XFIT and FOURYA, deposited in CCP14 Powder Diffraction Library, Engineering and Physical Sciences Research Council, Daresbury Laboratory, Warrington, England. (<http://www.ccp14.ac.uk/tutorial/xfit-95/xfit.htm>).