

New Ornament Notation for Woven Fabrics

Vytautas MILAŠIUS*, Jurgis KATUNSKIS, Dalia TAYLOR

Department of Textile Technology, Kaunas University of Technology, Studentų 56, LT-51424 Kaunas, Lithuania

Received 08 October 2005; accepted 13 March 2006

In spite of the fact that woven ornaments conform to symmetry concepts, in whose classification was proposed by Woods and then improved by Hann, three main distinctions from the general system can be observed – ornaments of the general system have continuous lines, whereas the line of a non-Jacquard woven ornament is a stepped line. Therefore axes or centres can be laid both between threads and on a thread. The backgrounds of a new notation system for non-Jacquard woven ornaments are presented in this article.

Keywords: monotranslational ornament, ditranslational ornament, symmetry groups, symmetry axes and centres.

INTRODUCTION

By analysing the ornamentation it is noted that ornaments conform to symmetry concepts, which were proposed by English physicist H. J. Woods [1] and later improved by M. A. Hann *et al* [2–4]. The backgrounds of this system for ditranslational ornaments are presented in Figure 1.

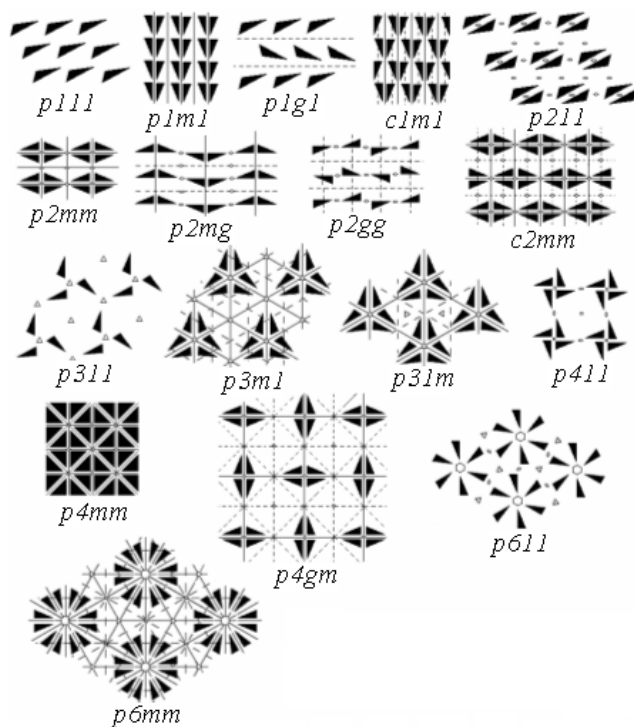

Fig. 1. Woods-Hann's notation system of ditranslational ornaments [2]

The importance of geometry in the construction of ornamental designs is more than evident. H. J. Woods wrote [1]: “The “science” of design, in fact, only a simplified and specialized part of that branch of physics devoted to the study of crystalline forms, “crystallography”, just as the later, to the mathematician, is

nothing but an application of the great branch of mathematics, the “Theory of Groups”.

The principles of symmetry can be an effective tool to study cross-cultural connections, as well as the oneness of culture showing different preferences. Washburn noted that artists and non-artists did not choose the same symmetries. Her results “confirm that there are general special salience for mirror reflection, in addition these results show how one kind of cultural experience (artistic activity) provides an overlay that leads to specific symmetrical arrangements” [5]. Special computer-aided programme was created to investigate the perception of symmetry peculiarities [6].

A number of investigators present interesting studies of symmetry peculiarities of patterns on decorated textiles from specific cultures. The essays of D. K. Washburn [7, 8] explore how cultural information is embedded in the symmetrical structure of a pattern. It was proven that groups of designs from any given cultural context show their own unique symmetry classes preferences. Members of a single cultural group tend to produce designs structured by few types of symmetries. The term cultural setting is a context of interacting individuals who share the same beliefs, values, attitudes, habits and forms of behavior that are transmitted from one generation to the next. Theoretically, all symmetries are available to be used to create repeating patterns and ornaments, but in reality, cultures consistently use only a few groups of symmetries [8]. According to D. K. Washburn, “throughout cultural groups such preferences are adopted and become known as a style”. The continuity of specific preferred symmetries over time establishes tradition.

Fundamental geometrical rules define this system. These rules are based on four symmetry operations. Any ornament can be created according to these operations: translation (Fig. 1), rotation (represented by the symbol \diamond), reflection (presented by straight line), glide-reflection (presented by dotted line).

Woods-Hann's classification and notation system of ornamentation divides all regularly repeating ornaments into three classes: finite ornaments, monotranslational ornaments and ditranslational ornaments. These three classes, depending on the combination of symmetry operations, and the lay of the centres and axes of

*Corresponding author. Tel.: +370-37-300221; fax.: +370-37-353989.
E-mail address: vytautas.milasius@ktu.lt (V. Milašius)

symmetry, are subdivided into two, seven and seventeen groups, respectively.

This system covers the ornaments that can be realized by all possible technology. It is expected that this system be also applied to study many ornaments of textiles created using various technologies – printing, embroidery, weaving (including non-Jacquard) – the latter being the most complicated and thus the most valuable way of decoration. While analysing woven textile ornamentation, it was noted that ornaments conform to these symmetry concepts [9, 10]. This notwithstanding, non-Jacquard woven designs have some distinctions [11] from the ornaments analysed by M. A. Hann. Before the computer-aided programme for the woven ornaments has been proposed [12, 13].

The main aim of this article is to analyse the main geometrical features of these designs and to propose the backgrounds of a new classification and notation system, which would reflect the basic constraints on the fundamental geometrical rules of creation of woven ornaments.

MAIN GEOMETRICAL FEATURES OF WOVEN ORNAMENTS

Woven non-Jacquard designs have some specific features caused by technology and the structure of the woven fabric:

- first, the line of a non-Jacquard woven ornament is a stepped line (Fig. 2), whereas ornaments described in general system have continuous lines (Fig. 3), consequently, symmetry axes or centres can be laid both between threads and on the thread (Fig. 4).

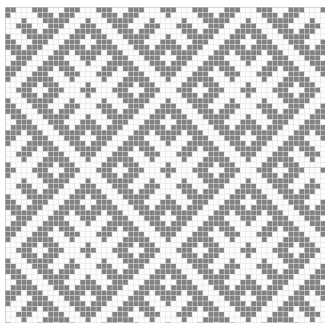

Fig. 2. Woven ornament

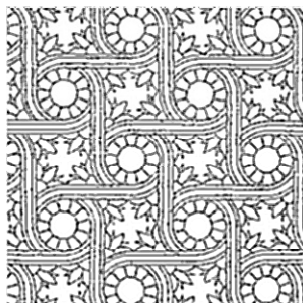

Fig. 3. Painted ornament

- second, as woven ornaments are formed from two perpendicular pattern threads, warp and weft, some symmetry groups of Woods-Hann's system can't be used for non-Jacquard woven designs (Fig. 5). From this distinction we can conclude that only twelve of the

seventeen ditranslational symmetry groups can be used for the description of non-Jacquard woven ornaments.



Fig. 4. Possible layout of symmetry axes and centres

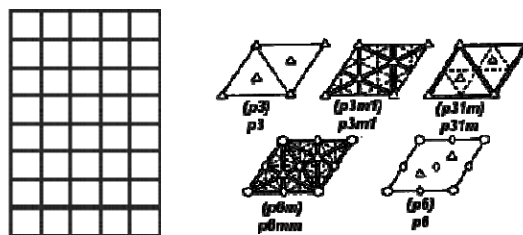

Fig. 5. Symmetry groups unrealizable for non-Jacquard woven ornaments

- the third distinction is derived from the second one, and deals with ditranslational symmetry operations: some of them can be carried out by transformation of the segment in two perpendicular directions (say, horizontally and vertically), which make two different ornaments.

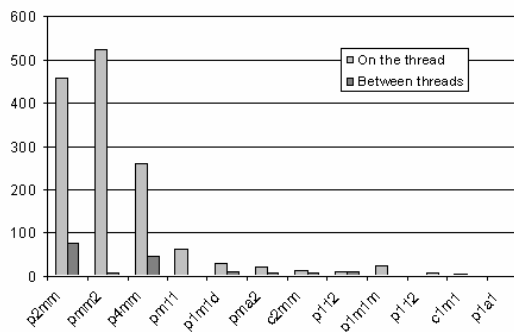

Fig. 6. Distribution of the layout of axes for various symmetry groups

We have analysed 569 woven Lithuanian national ornaments and have found more than 3,000 axes or centres of symmetry operations. The distribution of the layout of axes for various symmetry groups are shown in Figure 6. This diagram proves the limitations that rise from the possibility of axes or centres layout on the thread are very important for non-Jacquard woven ornaments because we have observed that more than 80 % of axes or centres are laid on the thread.

All these distinctions cause the need for the creation of an improved notation system for non-Jacquard woven ornaments.

BACKGROUNDS OF THE NEW NOTATION SYSTEM

The new complete notation system for woven ornaments contains international notation symbols and is supplemented by one, two, three or four groups of numbers. Every group of numbers contains two digits and specifies a particular operation of the segment transformation: the first digit specifies the symmetry operation (Table 1 and Table 2); the second digit can be either 0 (if the symmetry operation axis is on the thread) or 1 (if the symmetry

operation axis is between the threads). Di-translational ornaments, whose can be designed by transforming the segment either horizontally or vertically, must be specified by symbols describing the direction of the orientation, either *v* (vertically) or *h* (horizontally).

All symmetry operations (reflection, glide-reflection, and rotation) are used for the creation of definite symmetry group ornaments that can be divided into two groups (Fig. 7):

- first – symmetry operations, whose elements (axes and centres) can be laid either on the thread or between threads according to the choice of the designer (so called active axes, Fig. 7, a);
- second – those whose elements appear in definite positions by themselves, either depending on the position of the first group (Fig. 7, b) or their position is indispensable for certain symmetry group (Fig. 7, c). Type of element depends on basic geometrical features of given symmetry group.

The results of the geometrical analysis of the symmetry groups are presented in the sequent tables. Some symmetry groups have only active axes and centres, in

which case new notation is presented in Table 1.

Schemes of symmetry groups are presented as it is given by Hann [2]. Other ditranslational ornaments have various versions of axes and centres layouts (Table 2).

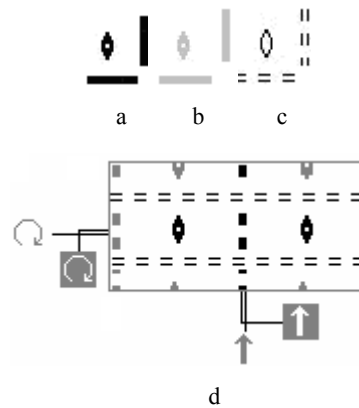

Fig. 7. Main principles of new notation system: a – active axes and centres, b – dependent elements, c – elements having indispensable position, d – example of ornament representation

Table 1. Ornamental symmetry groups, which all axes are active

Code and scheme of the symmetry group	Extra symbols												Orientation	Shift			
	1	2	3	4	5	7	7	7	7	7	7	7					
Monotranslational ornaments																	
<i>pm11</i> 	10	11			30	31											
<i>p1m1</i> 												70	71				
<i>p1a1</i> 												70	71				
<i>p112</i> 			20	21			40	41									
<i>p111</i> 	Translation only													zn			
Ditranslational ornaments																	
<i>p1m1</i> 	10	11			30	31										<i>v</i>	
										50	51	70	71				<i>h</i>
<i>p1g1</i> 	10	11			30	31											<i>v</i>
										50	51	70	71				<i>h</i>
<i>p111</i> 																	<i>v</i>
																	<i>h</i>

Table 2. Other ornaments symmetry groups







Code and scheme of the symmetry group	Extra symbols and layouts of axes and centres		
Monotranslational ornaments symmetry groups			
<p><i>pmm2</i></p> 	 <p>Rotation – two-fold, two centres having indispensable position. Reflection – three active axes lying in two directions.</p>		
<p><i>pma2</i></p> 	 <p>Rotation – one active centre, one centre having dependent position. Reflection – one active axis, one axis having dependent position. Glide-reflection – one axis having indispensable position lying in other direction.</p>		
Ditranslational ornaments symmetry groups			
	v	h	Shift
<p><i>c1m1</i></p> 	 <p>Reflection – one active axis, one axis having dependent position. Glide-reflection – two axes having indispensable position.</p>		
<p><i>p2mm</i></p> 	 <p>Rotation – two-fold, all centres of rotation are on reflection axes and have indispensable position. Reflection – four active axes lying in two directions.</p>		

Table 2. Other ornaments symmetry groups (continued)

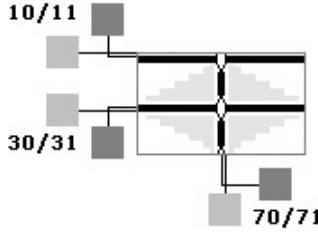

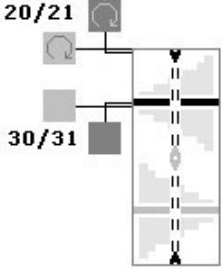

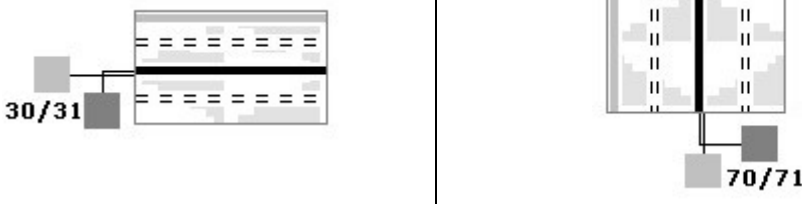

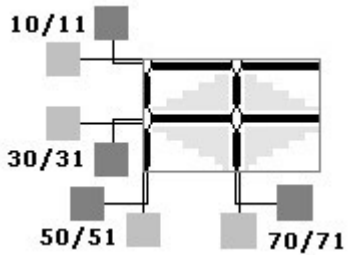

Code and scheme of symmetry group	Extra symbols and layouts of axes and centres	
<p><i>c2mm</i></p> 		
<p>Rotation – two-fold, all centres have indispensable position . Reflection – two active axes lying in two directions. Glide-reflection – one active axis, two having indispensable position, one having dependent position.</p>		
<p><i>p2mg</i></p> 		
<p>Rotation – two active centres lying in two directions, two centres having dependent position. Reflection – two-fold, one active axis, one axis having dependent position. Glide-reflection – two axes having indispensable position.</p>		
<p><i>p2gg</i></p> 		
<p>Rotation – two-fold, one sequence of two active centres, one sequence of two centres having dependent position. Glide-reflection – one active axis, one having dependent position, two having indispensable position lying in other direction.</p>		
<p><i>p211</i></p> 		 <p style="text-align: right;">zn</p>
<p>Translation – exists. Rotation – two-fold, two active centres lying in one direction shifted by n.</p>		

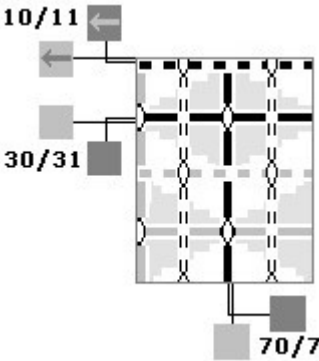
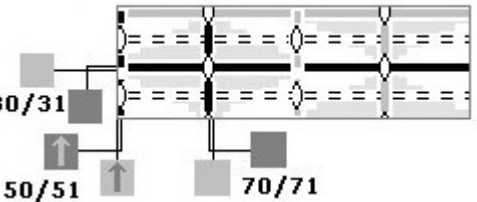
Table 2. Other ornaments symmetry groups (continued)

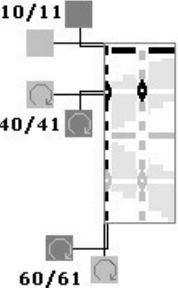
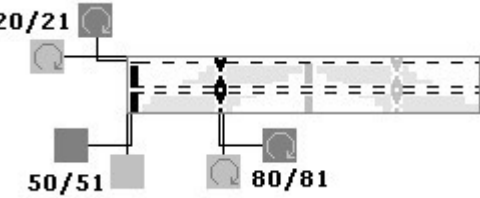
Code and scheme of symmetry group	Extra symbols and layouts of axes and centres	
<p><i>p4mm</i></p> 	 <p>Rotation – four-fold, having indispensable position.</p> <p>Reflection – two active axes, two having dependent position lying in other direction, there are other two axes having dependent position, which intersect at 45 degree.</p>	
<p><i>p4gm</i></p> 	 <p>Rotation – four-fold, one sequence of two active centres, one sequence of two centres having dependent position, two sequences of centres having indispensable position.</p> <p>Reflection – one active axis, one axis having dependent position, two axes having dependent position in other direction.</p> <p>Glide-reflection – two having dependent position, one having dependent and one having indispensable position in other direction, there are also other two axes having indispensable position, which intersect at 45 degree.</p>	
<p><i>p411</i></p> 	 <p>Rotation – four-fold, one centre having indispensable position, two-fold, two active centres lying in two directions.</p>	

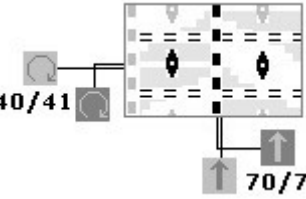
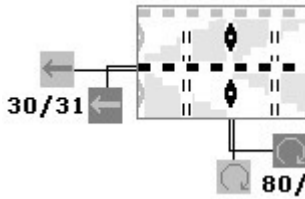
CONCLUSIONS

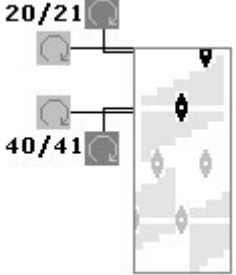
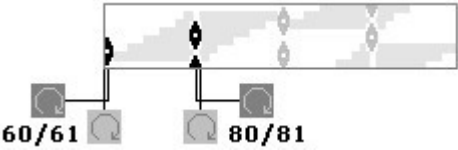
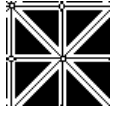
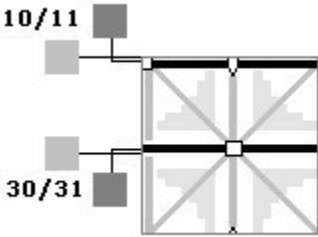
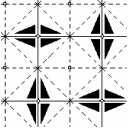
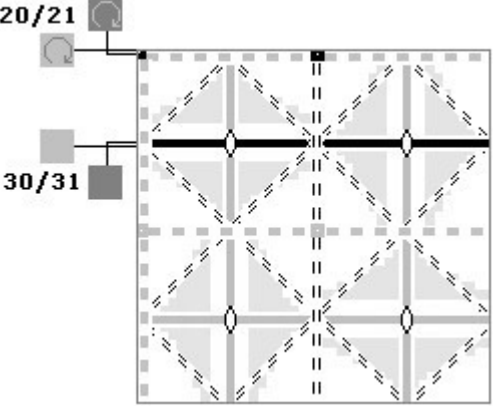
Specific features caused by technology and the structure of woven fabric cause the creation of an improved notation system for non-Jacquard woven ornaments. All elements (axes and centres) of various symmetry operations (reflection, glide-reflection, and rotation) used for the creation of definite symmetry group

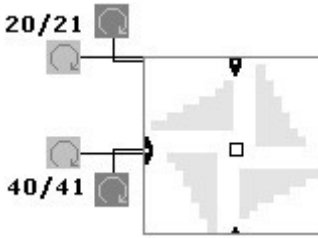
ornament depending on basic geometrical features of given symmetry group are divided into following groups: symmetry operations, in which elements can be laid either on the thread or between threads according to the choice of the designer (so called active axes), those, in which elements appear in definite positions by themselves depending on the position of the first group, and those

whose position is indispensable for certain symmetry groups. The results of the geometrical analysis of the symmetry groups are presented in the tables.

REFERENCES

1. **Woods, H. J.** The Geometrical Basis of Pattern Design. Part III: Geometrical Symmetry in Plane Patterns *J. Text. Inst.* 26 (1) 1935: pp. T341 – T357.
2. **Hann, M. A., Thompson, G. M.** The Geometry of Regular Repeating Patterns *Textile Progress* 22 (1) 1992: pp. 1 – 6.
3. **Hann, M. A.** Symmetry in Two-dimensional Design. A Review of its use in the Analysis and Synthesis of Regular Repeating Pattern *Proceedings of International Conference, The Textiles: Research in Design and Technology* Kaunas, Lithuania, September 21 – 22, 2000: pp. 14 – 18.
4. **Horne, C. E., Hann, M. A.** The Geometrical Basis of Patterns and Tilings: A Review of Conceptual Developments *J. Text. Inst. Part 2* 89 (1) 1998: pp. 27 – 46.
5. **Washburn, D. K., Humphrey, D.** Symmetries in Mind: Production, Perception, and Preference for Seven One-Dimensional Patterns *Visual Arts Research* 27 (2) 2001: pp. 57 – 68.
6. **Washburn, D. K.** Patterns at the Edge: Strategies of Looking at Nonrepresentational Art *Proceedings of the 20th Annual Conf. of the Cognitive Science Society* Univ. Wisconsin, Madison, 1998: pp. 1 – 5.
7. **Washburn, D. K.** The Property of Symmetry and the Concept of Ethnic Style *Archaeological Approaches to Cultural Identity*, London, Unwin Hyman, 1989: pp. 157 – 172.
8. **Washburn, D. K.** An Anthropological Perspective on the “Emperor’s Edict” *The Mathematical Intelligencer* 8 (4) 1986: pp. 66 – 72.
9. **Neverauskienė, D., Kazlauskienė, I., Milašius, V.** The Mathematical Basis of Ornamentation of Lithuanian Patterned Woven Fabrics *Ars Textrina: A Journal of Textiles and Costume* 34 2000: pp. 1 – 13.
10. **Neverauskienė, D., Kazlauskienė, I., Milašius, V.** The Symmetry Peculiarities of Ornamentation of National Lithuanian Woven Fabrics *Fibres & Textiles in Eastern Europe* 9 (1) 2001: pp. 63 – 67.
11. **Milašius, V., Katunskis, J., Neverauskienė, D., Kazlauskienė, I.** Computerized Creation of Woven Fabrics Ornamentation *Materials Science (Medžiagotyra)* 7 (4) 2001: pp. 307 – 312.
12. **Katunskis, J., Milašius, V., Taylor, D.** Software for Creation of a Database of Ornamentation of National Woven Fabrics *Fibres & Textiles in Eastern Europe* 12 (4) 2004: pp. 34 – 39.
13. **Taylor, D., Milašius, V., Katunskis, J.** Computerized Projection of Woven Textile Ornamentation *The Textile Institute 8th Annual World Conference* March 22 – 25, Raleigh, North Carolina, USA, 2005.

DOI: 10.5755/j02.ms.26304