

## Inverse Stress Relaxation in Textile Yarns After the Blockage of Viscoelastic Recovery

Rita POCIENĖ, Arvydas VITKAUSKAS\*

Department of Textile Technology, Kaunas University of Technology, Studentų 56, LT-51424 Kaunas, Lithuania

Received 27 February 2007; accepted 27 June 2007

Viscoelastic properties of acetate and polyester multifilament yarns in the compound loading cycle are theoretically and experimentally studied and the features of inverse stress relaxation (IR) after the blockage of viscoelastic recovery of the yarns are revealed in the study. Modelling method of the processes at the referred loading cycle is proposed on the basis of generalized Maxwell model. Analysing the behaviour of the model possessing different relaxation time spectra it was found that the longer is free recovery of the model until its blockage the less is the resulting recovery power of the model. The duration of recovery is more sensitive to the changes in the amount of the resulting IR in the model possessing more short relaxation times. To prove the theoretical findings the experimental investigation was provided with acetate (16.6 tex) and polyester (15.6 tex) multifilament yarns analysing their behavior in the same loading cycle. The experiments confirmed basic theoretical findings. Some differences in the reaction of acetate and polyester yarn to the blockage of their viscoelastic recovery are shown.

**Keywords:** inverse relaxation, recovery, acetate, polyester, Maxwell model.

### INTRODUCTION

One of distinct features of textiles, leather, plastics and other polymer materials is a well-marked viscoelasticity, manifesting in a high time-dependency of their mechanical behaviour. Study of materials viscoelastic behaviour is a subject of great importance from viewpoint of the theory of viscoelasticity originated from the material structure as well as from viewpoint of the material processing or its usage according to the specific purpose [1, 2]. To provide information about the viscoelastic behaviour of a polymeric material various experimental techniques have been used, among which stress relaxation, creep, and viscoelastic recovery after preceding sustaining at constant strain or at constant load are continually in common use [1, 3–11]. During last decades the inverse stress relaxation (IR) is also in the focus of attention for researchers [12–18].

In manufacturing or processing the viscoelastic recovery (VR) of textile products is often blocked to take the product a shape or size coinciding with the specified mould (tube, drum, beam etc.). When actions of similar nature are applied, the internal stresses arise in the product, indicating that the inverse stress relaxation process is taking place in the product [19, 14]. In this study we sought to reveal how the inverse relaxation manifesting in such compound loading cycle of textile yarns depended on both the time over which the yarn was sustained extended into unloading and the time of the yarn recovery before it was blocked at specified strain.

### LOADING CYCLE AND MODELLING

The analysed compound cycle of yarn loading consisted of five phases (Fig. 1): a) constant rate ( $v_i$ ) extension over the time  $0-t_i$  up to strain limit  $\varepsilon_i$ ;

b) sustaining at  $\varepsilon_i = \text{const}$  over the time interval  $\theta_i$  while measuring stress relaxation (R) in the specimen; c) constant rate ( $v_a$ ) retraction down to minimum load  $F_a$  (e.g. to pretension or zero) corresponding to strain  $\varepsilon_a$  at time  $t_a$ ; d) viscoelastic recovery (VR) of unloaded specimen at  $F_a = \text{const}$  over the time interval  $t_i - t_a$ ; e) blocking of the recovery at given strain  $\varepsilon'_a$  corresponding to time  $t_i$  and sustaining onward at strain  $\varepsilon'_a$  while measuring inverse stress relaxation (IR) in the specimen.

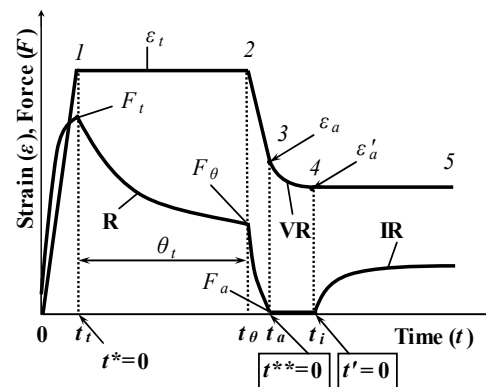
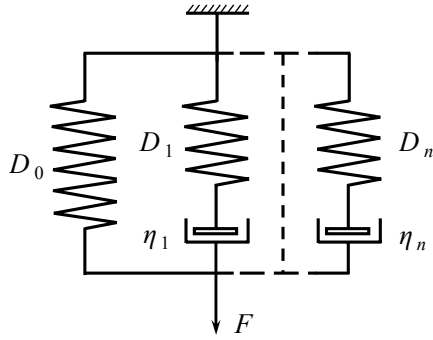

Fig. 1. The outline of compound loading cycle

Theoretical study of stress development in such cycle of loading is provided analysing the behaviour of generalized Maxwell model consisting of a discrete number of Maxwell units ( $i = 1, 2, \dots, n$ ) and of a single spring in parallel (Fig. 2).  $D_0, D_i$  are elasticity constants of the model springs, and  $\eta_i$  are viscosity constants of the dashpots. Relaxation times  $\tau_i = \eta_i / D_i$  of the Maxwell units were settled to differ between themselves by one order of magnitude, i.e. the model to possess regular discrete relaxation time spectrum [20, 21]. Since it was foreseen to analyse the yarn viscoelastic behavior over the large period of time, the number of Maxwell units in the model was taken as  $n = 5$  [21]. It has been formerly shown [20, 21]

\*Corresponding author. Tel.: +370-37-300224; fax.: +370-37-353989. E-mail address: Arvydas.Vitkauskas@ktu.lt (A. Vitkauskas)

that short relaxation times prevail over the long ones in the spectra of various textile yarns. Therefore, to analyze the model behavior we chose two idealized forms of the model spectrum – “peak” and “wedge” – that are typified by corresponding features. The constants of the model for both two forms of spectrum are presented in [22, 23].



**Fig. 2.** The generalized Maxwell model

Special method of gradually alternating retraction rate [24] is applied to express viscoelastic recovery of the model at constant tension  $F_a$  over time interval  $(t_i - t_a)$ . The referred time interval is discretized into a set of sequential time points  $t_j^{**}$  ( $j=1,2,3,\dots$ ) beginning from  $t_j^{**}=0.01$ , step 0.125 of time logarithm. Within every interval between the successive time points  $t_j^{**}$  the model is retracted at the rate to get the specified value of  $F_a$  at the end of the interval (the value  $F_a=0$  has been taken in the present study). According to Boltzmann superposition principle, at any time point  $t_s^{**}$  (when  $j=s$ ) the tension  $F_s = F_a$  can be expressed by the sum of two components:

$$F_s = F_{IRs} - F_{VRs}. \quad (1)$$

The component  $F_{IRs}$  is a tension of the model developing due to inverse stress relaxation going on at  $\varepsilon_a = \text{const}$ :

$$F_{IRs} = D_0 \varepsilon_a + \sum_{i=1}^n A_i \exp\left(-\frac{t_s^{**}}{\tau_i}\right), \quad (2)$$

where  $n$  is a number of Maxwell units in the model (in our case  $n=5$ ), and

$$A_i = D_i \tau_i \left[ v_t \left\{ 1 - \exp\left(-\frac{\varepsilon_t}{v_t \tau_i}\right) \right\} \cdot \exp\left(-\frac{\theta_t}{\tau_i}\right) \cdot \exp\left(-\frac{\varepsilon_t - \varepsilon_a}{v_a \tau_i}\right) - v_a \left\{ 1 - \exp\left(-\frac{\varepsilon_t - \varepsilon_a}{v_a \tau_i}\right) \right\} \right]. \quad (3)$$

$F_{VRs}$  is a compensatory tension component:

$$F_{VRs} = D_0 (\varepsilon_a - \varepsilon_s) + \sum_{j=1}^{s-1} B_j \exp\left(-\frac{t_s^{**} - t_j^{**}}{\tau_i}\right) + C_s, \quad (4)$$

where

$$B_j = \frac{\varepsilon_{j-1} - \varepsilon_j}{t_j^{**} - t_{j-1}^{**}} \sum_{i=1}^n D_i \tau_i \left\{ 1 - \exp\left(-\frac{t_j^{**} - t_{j-1}^{**}}{\tau_i}\right) \right\}, \quad (5)$$

and

$$C_s = \frac{\varepsilon_{s-1} - \varepsilon_s}{t_s^{**} - t_{s-1}^{**}} \sum_{i=1}^n D_i \tau_i \left\{ 1 - \exp\left(-\frac{t_s^{**} - t_{s-1}^{**}}{\tau_i}\right) \right\}. \quad (6)$$

At every successive time point  $t_s^{**}$  the value of strain  $\varepsilon_s$  decreases to get  $F_s = F_a = \text{const}$  (eq. 1). So, the process of viscoelastic recovery can be displayed as function of  $\varepsilon_s$  versus time  $t_s^{**}$ . When viscoelastic recovery of the model is blocked at specified strain  $\varepsilon_s = \varepsilon'_a$  corresponding to the time point  $t' = t_s^{**} - (t_i - t_a)$ , the value of  $C_s$  (6) becomes steady, and, consequently, tension of the model begins to increase with time.

Since the modelling is provided a priori to the experiments, it is no need to specify measuring units of the model constants likewise the parameters of the deformation cycle and all calculated results. All these values are regarded as being expressed in conventional coherent measuring units. Herein the parameters of loading cycle were as follows: the extension and retraction rates  $v_t = v_a = 100$ , the upper strain limit  $\varepsilon_t = 10$ , and the tension at the end of retraction  $F_a = 0$ ; the time of model sustention in extended state before retraction ( $\theta_t$ ) was varied.

Stress increase  $(F - F_a)$  curves of the model after different sustaining time  $\theta_t$  for the “peak” and “wedge” spectres are presented in Fig. 3. It is seen that the character of stress increase during IR process is highly dependent on the sustention time  $\theta_t$  and also on the type of relaxation time spectrum of the model. However, it can be definitely stated that the longer is free recovery of the model until its blockage at strain  $\varepsilon'_a = \text{const}$ , the less is the resulting recovery power (i. e., the amount of IR) of the model. The “peak” spectrum of the model is characterized by greater contribution of short relaxation times, so the amount of inverse relaxation in it is more affected by the time of free recovery of the model and is less than in the model possessing “wedge” spectrum. For the same reason the unloading time interval  $(t_a - t_\theta)$  of the model with “peak” spectrum is less influenced by the model’s sustention time  $\theta_t$ , and this results in more smooth drop of IR amount with increase of recovery time  $(t_i - t_a)$ , especially at short sustention time, say,  $\theta_t = 10$  (Fig. 4, a). For the model with “wedge” spectrum even short-time recovery results in substantial drop of the IR amount (Fig. 4, b) and the character of this drop is more influenced by the sustention time  $\theta_t$ .

## EXPERIMENTAL

Two different types of multifilament yarns: acetate (CA, 16.6 tex) and polyester (PES, 15.6 tex) were tested in the above referred compound loading cycle. The tests were provided on Zwick/Z005 universal testing machine operated by the programme *testXpert®* at the gauge length of 700 mm. In all tests the rate of extension ( $v_t$ ) was 525 mm/min (1.25 %/s) and it was equal to the rate of retraction ( $v_a$ ). The pretension was 2.4 mN/tex and it was equal to the level of tension on the specimen during its viscoelastic recovery over the time interval  $(t_i - t_a)$ . The upper extension limits were:  $\varepsilon_t = 9.1$  % of initial length for CA yarn, and  $\varepsilon_t = 10$  % for PES yarn. The sustention time  $\theta_t$  was varied: 10 s, 100 s and 1000 s.

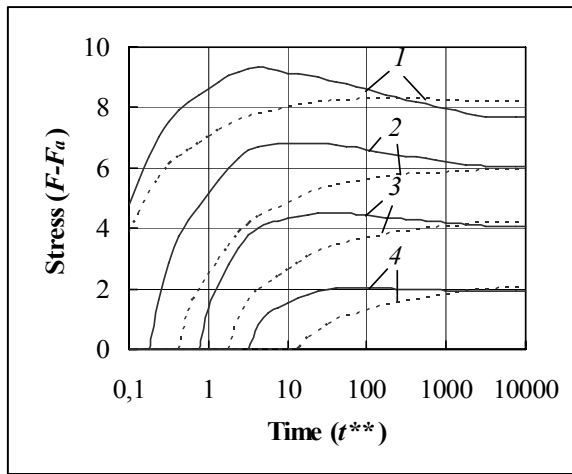

a

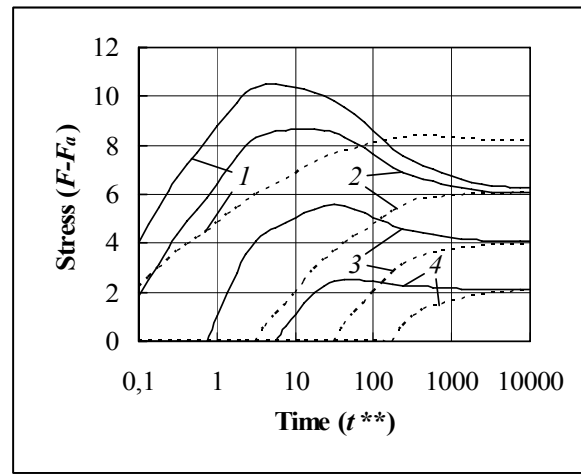

b

**Fig. 3.** Inverse stress relaxation (IR) in the model possessing different relaxation time spectra (a – “peak”, b – “wedge”) over time  $t^{**}$  after the blockage of recovery (VR) at different strains  $\varepsilon'_a$ : primary extension  $\varepsilon_i = 10$ ; sustention time  $\theta_i = 10$  (—), and  $\theta_i = 1000$  (- - -); strains  $\varepsilon_a$ : for “peak” spectrum – 7.69 at  $\theta_i = 10$ , 8.01 at  $\theta_i = 100$ , and 8.18 at  $\theta_i = 1000$ ; for “wedge” spectrum – 6.29 at  $\theta_i = 10$ , 7.58 at  $\theta_i = 100$ , and 8.16 at  $\theta_i = 1000$ ; strain  $\varepsilon'_a$ : 1 – ( $\varepsilon'_a = \varepsilon_a$ ); 2 – 6.1; 3 – 4.2; 4 – 2.2

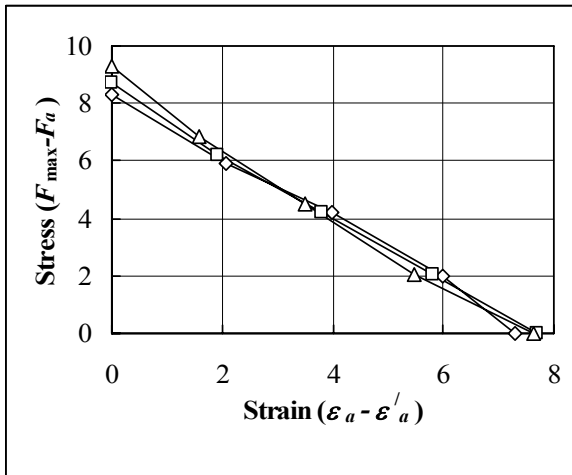

a

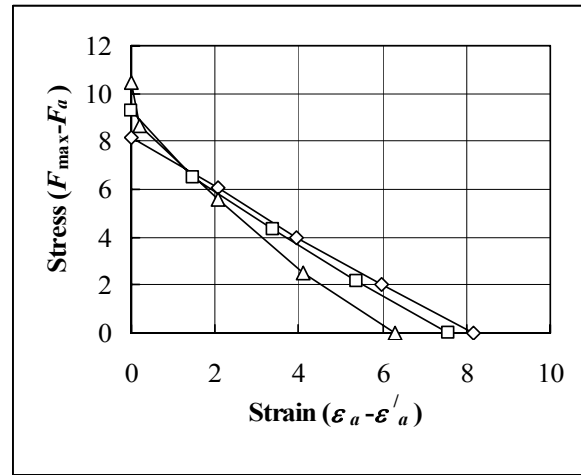

b

**Fig. 4.** Dependence of maximum amount of IR grown up in the model after the blockage of VR on the amount of recovery developed over the period of time ( $t_i - t_a$ ):  $\Delta$  –  $\theta_i = 10$ ;  $\square$  –  $\theta_i = 100$ ;  $\diamond$  –  $\theta_i = 1000$ ; a – “peak” spectrum, b – “wedge” spectrum

## RESULTS AND DISCUSSION

Experimental IR curves of CA and PES yarns obtained in the referred deformation cycle at different sustaining times ( $\theta_i$ ) are presented in Fig. 5 and Fig. 6 correspondingly. It is seen that for both yarns the recovery power, i. e., the amount of IR, substantially decreases with increase of the time ( $t_i - t_a$ ) of free viscoelastic recovery until its blockage. The influence of sustention time  $\theta_i$  at primary extension up to  $\varepsilon_i$  is different: the amount of IR in acetate yarn decreases with increase of sustention time (see Fig. 5, curves 2, 3, 4, and 6) while the amount of IR in PES yarn is approximately the same at different sustention times. It is interesting to notice that the initial slope of IR curves of acetate yarn with respect to time axis (in logarithmic scale) can be as a first approximation evaluated being steady for different strain blockage levels  $\varepsilon'_a$  and different sustention times  $\theta_i$ . This feature is not tenable for PES yarns: initial slopes of curves are steeper at higher levels of strain  $\varepsilon'_a$  and at longer sustention times.

In Fig. 7 the dependencies of the amount of IR in the yarns at blocked strain  $\varepsilon'_a$  on the corresponding amounts of free recovery are presented. The dependencies can be regarded as approximately linear with the slope being nearly invariant with respect to sustention time  $\theta_i$ . The dependencies are qualitatively similar to the corresponding theoretical (Fig. 4) dependencies. So, obviously it is possible to predict qualitatively the features of inverse relaxation after the blockage of viscoelastic recovery by the proposed modelling method. The discrepancies between corresponding experimental and theoretical dependencies can be first of all explained by the different stresses taken as reference values in the dependencies. In experiments it was no possibility in all cases to observe inverse relaxation until the yarn stress reached its maximum value. For this reason yarn stresses at  $t^{**} = 1000$  s were taken as reference values in the dependencies. Since with decrease of strain level  $\varepsilon'_a$  the maximum points on IR curves move along time  $t^{**}$  axis, at

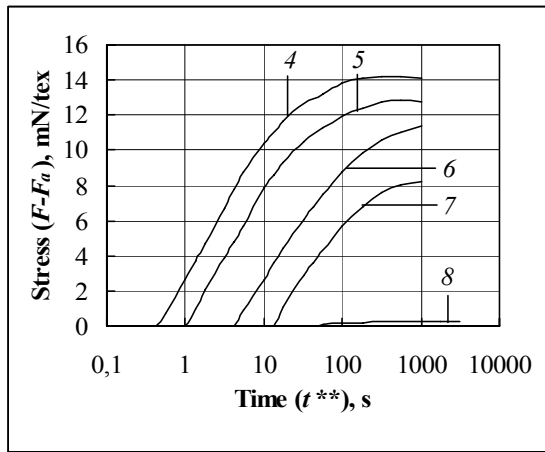

a

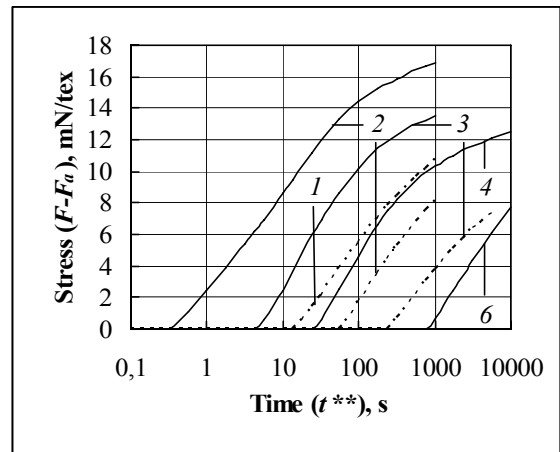

b

**Fig. 5.** Inverse relaxation (IR) in CA yarn over time  $t^{**}$  after the blockage of recovery (VR) at different strains  $\epsilon'_a$ : primary extension  $\epsilon_i = 9.1\%$ ; sustention time  $\theta_i = 10$  s (a),  $\theta_i = 100$  s (b, —), and  $\theta_i = 1000$  s (b, - - -); strain  $\epsilon'_a$ , %: 1 – 8.00; 2 – 7.80; 3 – 7.50; 4 – 6.90; 5 – 6.70; 6 – 6.30; 7 – 6.00; 8 – 5.40

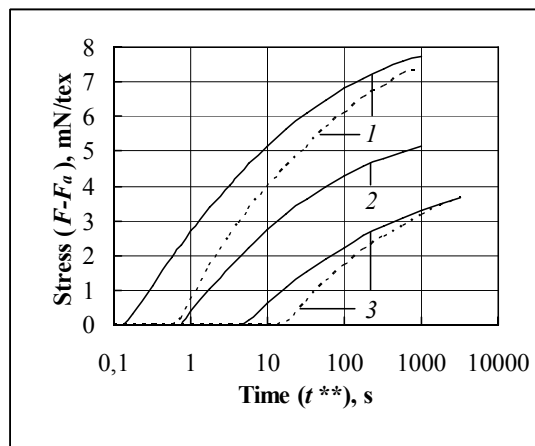

**Fig. 6.** Inverse relaxation (IR) in PES yarn over time  $t^{**}$  after the blockage of recovery (VR) at different strains  $\epsilon'_a$ : primary extension  $\epsilon_i = 10.0\%$ ; sustention times  $\theta_i = 100$  s (—), and  $\theta_i = 1000$  s (- - -); strains  $\epsilon'_a$ , %: 1 – 1.00; 2 – 0.60; 3 – 0.30

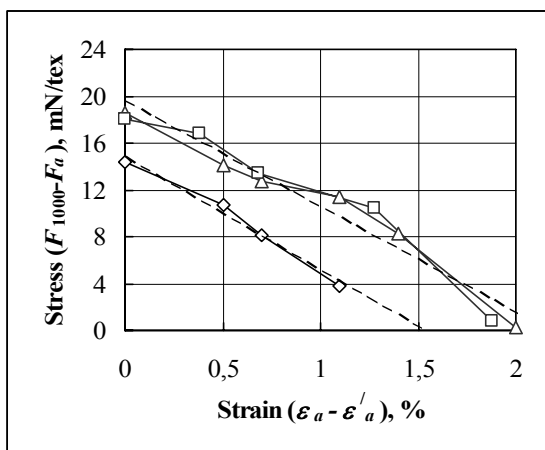

a

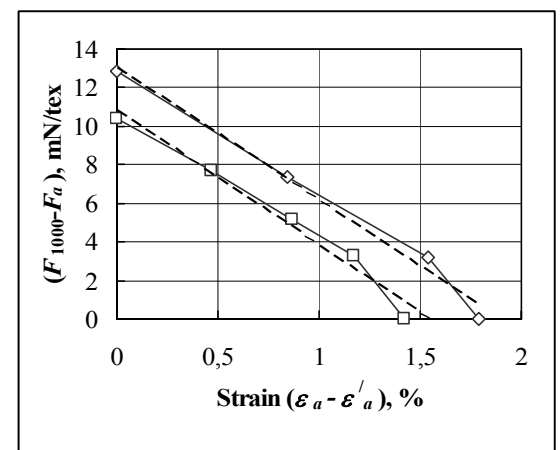

b

**Fig. 7** Dependence of amount of IR in the yarns grown up the time  $t^{**} = 1000$  s after the blockage of VR on the amount of recovery developed over the period of time  $(t_i - t_a)$ :  $\triangle - \theta_i = 10$  s,  $\square - \theta_i = 100$  s,  $\diamond - \theta_i = 1000$  s; a – CA yarn, b – PES yarn

the lowest levels of strain  $\epsilon'_a$  yarn stresses are still far away from their maximum values, and these points seem to be the main ones disturbing the linear dependencies shown in Fig. 7.

## CONCLUSIONS

The features of inverse stress relaxation (IR) after the blockage of viscoelastic recovery of textile yarns are revealed in the study. Modelling method of the processes at the compound loading cycle is proposed on the basis of generalized Maxwell model. Analysing the behaviour of the model possessing different relaxation time spectra it was found that the longer is free recovery of the model until its blockage the less is the resulting recovery power of the model. The duration of recovery is more sensitive to the changes in the amount of the resulting IR in the model possessing more short relaxation times. The experiments provided on acetate and polyester multifilament yarns confirmed basic theoretical findings. Some differences in the reaction of acetate and polyester yarn to the blockage of their viscoelastic recovery are shown.

## REFERENCES

1. **Leaderman, H.** Elastic and Creep Properties of Filamentous Materials and Other High Polymers. 2<sup>nd</sup> print, Washington: The Textile Foundation, 1944.
2. **Nielsen, L. E., Landel, R. F.** Mechanical Properties of Polymers and Composites. 2<sup>nd</sup> ed., New York/Basel: Marcel Dekker, Inc., 1994.
3. **Abbot, N. J.** Extension and Relaxation of Nylon Filaments *Textile Research Journal* 21 (4) 1951: pp. 227 – 234.
4. **Meredith, R.** Relaxation of Stress in Stretched Cellulose Fibres *Journal of the Textile Institute* 45 (6) 1954: pp. T438 – T461.
5. **Kukin, G. N., Solv'ev, A. N.** An Investigation of Creep Recovery in Textile Yarns *The Papers of Moscow Textile Institute* 17 1956: pp. 142 – 165 (in Russian).
6. **Rae, A.** A Study of the Extension of Woolen Yarn During Winding and of its Subsequent Relaxation *Journal of the Textile Industry* 50 (5) 1959: pp. P224 – P237.
7. **Guthrie, J. C., Wibberley, J.** The Effect of Time on the Elastic Recovery of Fibres *Journal of the Textile Institute* 56 (3) (March) 1965: pp. T97 – T103.
8. **Gupta, V. B., Gopal Krishnan, Y.** Creep and Recovery Behaviour of Oriented Nylon 6 Filaments *Indian Journal of Textile Research* 1 (3) 1976: pp. 95 – 98.
9. **Yamaguchi, T., Kitagawa, T., Yanagawa, T., Kimura, H.** Relationship Between Stress Relaxation and Tensile Recovery of Filament Yarns *Journal of the Textile Machinery Society of Japan* 27 (2) 1981: pp. 43 – 49.
10. **Bhuvanesh, Y. C., Gupta, V. B.** Interaction Between Viscoelastic and Structural Relaxation in Drawn Polypropylene Yarn *Polymer* 36 (19) 1995: pp. 3669 – 3674.
11. **Manich, A. M., Ussman, M. H., Barella, A.** Viscoelastic Behavior of Polypropylene Fibers *Textile Research Journal* 69 (5) 1999: pp. 325 – 330.
12. **Vitkauskas, A., Matukonis, A.** Phenomenological Presentation of the Inverse Stress Relaxation of a Yarn under a Tension Load *Technology of the Textile Industry U.S.S.R.* 4 1968: pp. 19 – 21.
13. **Manich, A. M., De Castellar, M. D.** Elastic Recovery and Inverse Relaxation of Polyester Staple Fiber Rotor Spun Yarns *Textile Research Journal* 62 (4) 1992: pp. 722 – 726.
14. **Nachane, R. P., Sundaram, V.** Analysis of Relaxation Phenomena in Textile Fibres Part II: Inverse Relaxation *The Journal of the Textile Institute* 86 (1) 1995: pp. 20 – 32.
15. **Vangheluwe, L.** Relaxation and Inverse Relaxation of Yarns After Dynamic Loading *Textile Research Journal* 63 (9) 1993: pp. 552 – 556.
16. **Kothari, V. K., Rajkhowa, R., Gupta, V. B.** Stress Relaxation and Inverse Stress Relaxation in Silk Fibers *Journal of Applied Polymer Science* 82 2001: pp. 1147 – 1154.
17. **Lee, H.-J., Zhang, P., Bravman, J. C.** Stress Relaxation in Free-standing Aluminum Beams *Thin Solid Films* 476 (1) 2005: pp. 118 – 124.
18. **Pocienė, R., Vitkauskas, A.** Inverse Stress Relaxation and Viscoelastic Recovery of Multifilament Textile Yarns in Different Test Cycles *Materials Science (Medžiagotyra)* 11 (1) 2005: pp. 68 – 72.
19. **Böhringer, H.** Das Arbeitsvermögen als zentraler Informationswert für Textilien *Faserforschung und Textiltechnik* Heft 1 13 1962: pp. 10 – 26.
20. **Vitkauskas, A.** Description of Stress Relaxation Curves by Means of a Regular Discrete Relaxation Times Spectrum *Tekhnologiya Tekstil'noy Promyshlennosti (Technology of Textile Industry)* 2 1994: pp. 18 – 22 (in Russian).
21. **Vitkauskas, A.** Regular Discrete Relaxation Time Spectrum of Textiles *Materials Science (Medžiagotyra)* 2 1996: pp. 65 – 71.
22. **Vitkauskas, A.** Inverse Relaxation and Delayed Elastic Recovery of Textile Yarns: Resemblant or Disparate? *Textiles and the Information Society – The 78<sup>th</sup> World Conference of The Textile Institute*, Thessaloniki, Greece. Vol. III, 1997: pp. 469 – 474.
23. **Vitkauskas, A.** Influence of Alternating Rate of Extension on Stress Relaxation in Textile Yarns *Materials Science (Medžiagotyra)* 1 1997: pp. 52 – 57.
24. **Vitkauskas, A.** Representation of Elastic Strain Recovery by Generalized Maxwell Model *Tekstilės ir odos technologija (Textile and Leather Technology)* 18 1990: pp. 5 – 19 (in Lithuanian).

DOI: 10.5755/j02.ms.26338