

## Fatigue Strength of Chromium-Plated Steel

Valdas KVEDARAS<sup>1\*</sup>, Jonas VILYS<sup>2</sup>, Vytautas ČIUPLYS<sup>2</sup>, Antanas ČIUPLYS<sup>2</sup>

<sup>1</sup>Department of Technological Processing, Klaipėda University, Bijūnų 17, LT-91225 Klaipėda, Lithuania

<sup>2</sup>Department of Metals Technology, Kaunas University of Technology, Kęstučio 27, LT-44312 Kaunas, Lithuania

Received 14 June 2005; accepted 05 January 2006

In this research, fatigue strength of pyrolytic chromium-plated steel was studied. Depending on operating temperatures of pyrolytic chromium-plating process on the surface of steel specimens chromium coatings with homogeneous, horizontal-layered and columnar (dendritic) structures were formed. The speed of formation chromium coatings during pyrolytic chromium-plating process was 5 μm/min – 6 μm/min. The microhardness of formed chromium coatings was 10000 MPa – 20000 MPa. Rotating bending fatigue test results have shown that after pyrolytic chromium-plating the fatigue strength of steel can be improved as well as considerably worsened. It was determined, that chromium coatings having three different microstructures had different resistant to cyclic load. The chromium coatings with homogeneous or horizontal-layered structures are suitable for increasing of fatigue strength of investigated material.

*Keywords:* fatigue, pyrolytic chromium-plating, chromium coating.

### INTRODUCTION

The fatigue behaviour in comparison with static loading has unusually high sensitivity to conditions of the surface layer and any major change on the surface will affect the fatigue strength of metal. The influence of conditions of the metal surface on fatigue strength is caused by earlier damage of the surface layer in comparison with other volume of metal. The fatigue failure begins at the metal surface or near the surface (in 1 – 2 grains of metal) and propagates across the volume [1, 2]. Therefore, using the strengthening of surface it is possible considerably to improve the resistance to the fatigue crack initiation and increase the fatigue life of metals and alloys.

At present, there are many various surface treatment methods (about two hundred methods) that are found with developing of surface science and techniques [3]. However, the effect of various surface treatments on the fatigue behaviour is very different, i.e. there are many examples of the increased and, in some cases, of the decreased fatigue strength after the surface treatment. The efficiency of surface treatments depend on many factors: on the depth and structure of the modified layer, surface residual stresses, hardness of surface layer, adhesion and other factors, which interrelationship is not thoroughly studied till now.

One of the surface strengthening methods is chromium-plating. It is known that after chromium-plating wear resistance, corrosive resistance, erosion resistance, heat resistance of steel parts considerably improves [3 – 6].

Unfortunately, the chromium-plating is difficult to accomplish without impairment of fatigue properties. The basic reason of impairment of fatigue strength of chromium-plated material is connected with creation in surface layer tensile residual stresses [6 – 8].

The purpose of this work is to investigate the effect of pyrolytic chromium – plating on the fatigue strength of steel.

### EXPERIMENTAL

As object of the research normalized constructional steel was chosen. The chemical composition (wt %) of this steel was: 0.49 C, 0.55 Mn, 0.24 Si, 0.6 Cr, 1.2 Ni, 0.13 Cu. The specimens were prepared from this material and had minimal diameter of 7.52 mm and gauge length of 20 mm. The surface of specimens was grinded. The fatigue tests were carried out by rotating-beam fatigue machine (MUI-6000) with frequency of load alternation 3000 cycles/min. The hardness was measured by microhardness testing tester (PMT-3). The cross-sectional micrographs were examined using optical microscope “Neophot”. The microstructure has been developed by etching polished surface with 3 % nitric acid solution in ethanol. The testing was done at room temperature.

During the pyrolytic chromium-plating process at surroundings of argon (Ar) gases and at 70 Pa – 133 Pa pressure thermal decomposition of metalloorganic compound vapour on heated (350 °C – 500 °C) base (specimens) occurs. In this way chromium coating is formed. The chromoorganic solution “Barchos” was used as metalloorganic compound. The scheme of pyrolytic chromium-plating installation is presented in Figure 1. In pyrolytic chromium-plating process the chromoorganic solution is supplied to vaporizer 2, which is installed at top part of the reaction chamber 1.

The chromoorganic solution is heated by heating cell 3 up to 200 °C in the vaporizer. Then vapour of metalloorganic compound (MOC) gets into the reaction zone, where the steel specimen 5 is placed.

The specimens were heated by heating cell 4 in order to make up suitable conditions for thermal decomposition. Thermal decomposition of the molecules (pyrolysis) of metalloorganic compound occurs when surface of the specimen radiates heat and in this way the coating is formed. The decomposition products are removed from the reaction chamber by a vacuum pump 6. Besides, it needs to be mentioned that pyrolytic chromium-plating process is very productive (the speed of formation chromium coating

\*Corresponding author. Tel.: +370-46-398696; fax: +370-46-398682. E-mail address: valdas.kvedaras@ku.lt (V. Kvedaras)

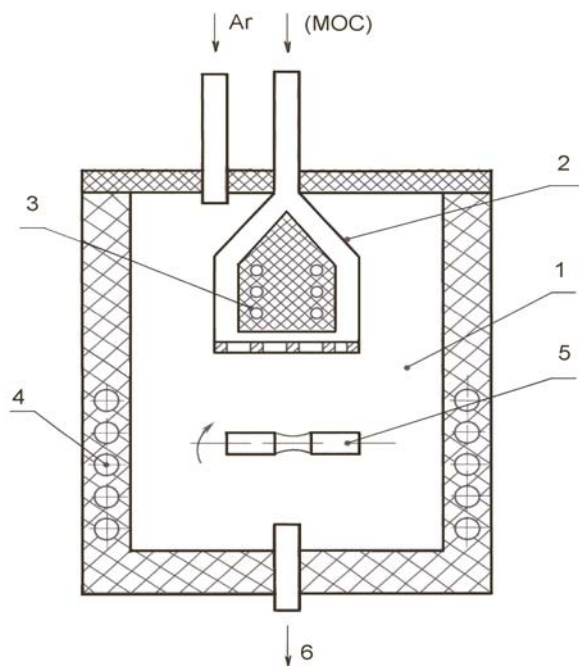

**Fig. 1.** The scheme of pyrolytic chromium-plating installation:  
1 – reaction chamber, 2 – vaporizer, 3 and 4 – heating cells, 5 – specimen, 6 – vacuum pump

is  $5 \mu\text{m}/\text{min} \div 6 \mu\text{m}/\text{min}$ ) and surface of the specimen doesn't need any special preparation.

## RESULTS AND DISCUSSION

The investigations have shown that the microstructure of chromium coating depended on operating temperature of chromium-plating process. After pyrolytic chromium-plating on the surface of specimens chromium coatings with three different microstructures were formed (Fig. 2).

At operating temperatures  $350 \text{ }^\circ\text{C} - 410 \text{ }^\circ\text{C}$  the coatings with homogeneous structure (Fig. 2, a) were formed. The microhardness of these coatings was  $10000 \text{ MPa} - 12000 \text{ MPa}$ . At operating temperatures  $410 \text{ }^\circ\text{C} - 490 \text{ }^\circ\text{C}$  coatings had horizontal-layered structure with one after another following white and black layers (Fig. 2, b). The microhardness of these coatings was  $13000 \text{ MPa} - 17000 \text{ MPa}$ . At operating temperatures higher as  $490 \text{ }^\circ\text{C}$  coatings had columnar (dendritic) structure (Fig. 2, c). The microhardness of these coatings was  $17000 \text{ MPa} - 20000 \text{ MPa}$ . The thickness of all chromium coatings was  $0.01 \text{ mm}$ .

The fatigue tests have shown that in the case of chromium coatings with columnar (dendritic) structures fatigue strength of specimens was rather worse: the fatigue limit ( $\sigma_{-1}$ ) decreased up to 29 % and limited durability decreased more than 9 times (Fig. 3, curve 4) in comparison with origin material. Worsening of fatigue strength can be explained as a result of increase of structural defects at dendritic interfaces. Connection between the separate dendrites becomes worse and therefore in chromium-plated surface fatigue crack originates more quickly. In the case of chromium coatings with horizontal-layered structures, the fatigue limit ( $\sigma_{-1}$ ) increased up to 17 % and limited

durability almost didn't change in comparison with origin metal (Fig. 3, curve 3).

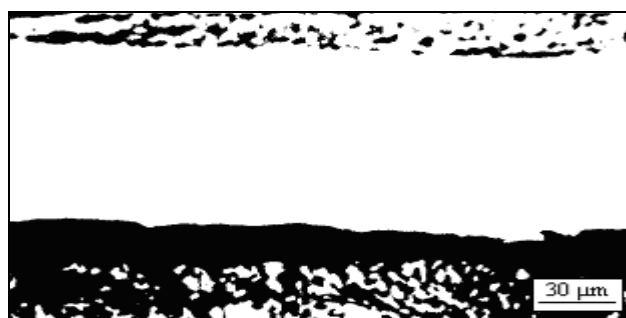

a

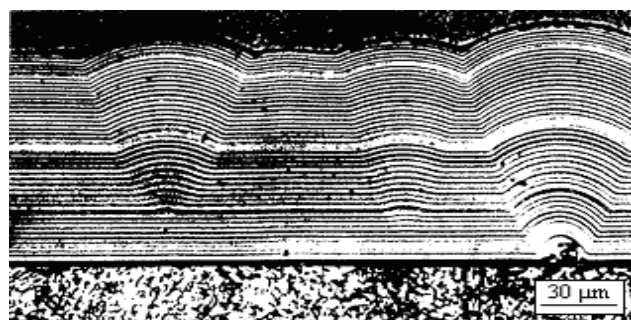

b

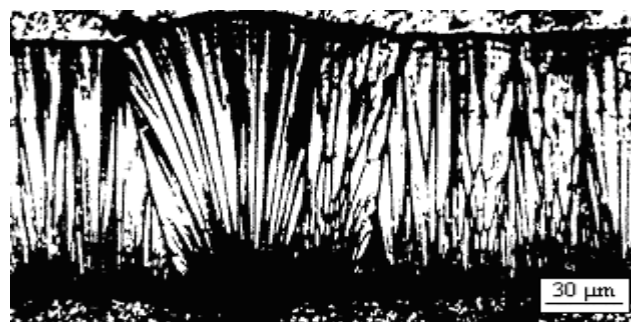

c

**Fig. 2.** Microstructures of chromium coatings: a – homogeneous, b – horizontal-layered, c – columnar (dendritic)

This fact shows that chromium-plated parts with horizontal-layered structure of chromium coatings can safely work only when acting cyclic load slightly exceeds fatigue limit of the steel base. In the case of chromium coatings with homogeneous structure, the fatigue limit ( $\sigma_{-1}$ ) of investigated steel didn't change and limited durability increased 3 times (Fig. 3, curve 2) in comparison with the virgin metal.

The experimental investigations have shown that depending on the operating temperature of pyrolytic chromium-plating process chromium coatings of different microstructures can be formed. These coatings make diverse influence on fatigue strength of chromium-plated material. In the case of chromium coatings with homogeneous or horizontal-layered structure the fatigue strength of investigated material has been improved. However, when the chromium coating with columnar (dendritic) structures was formed, the fatigue strength of

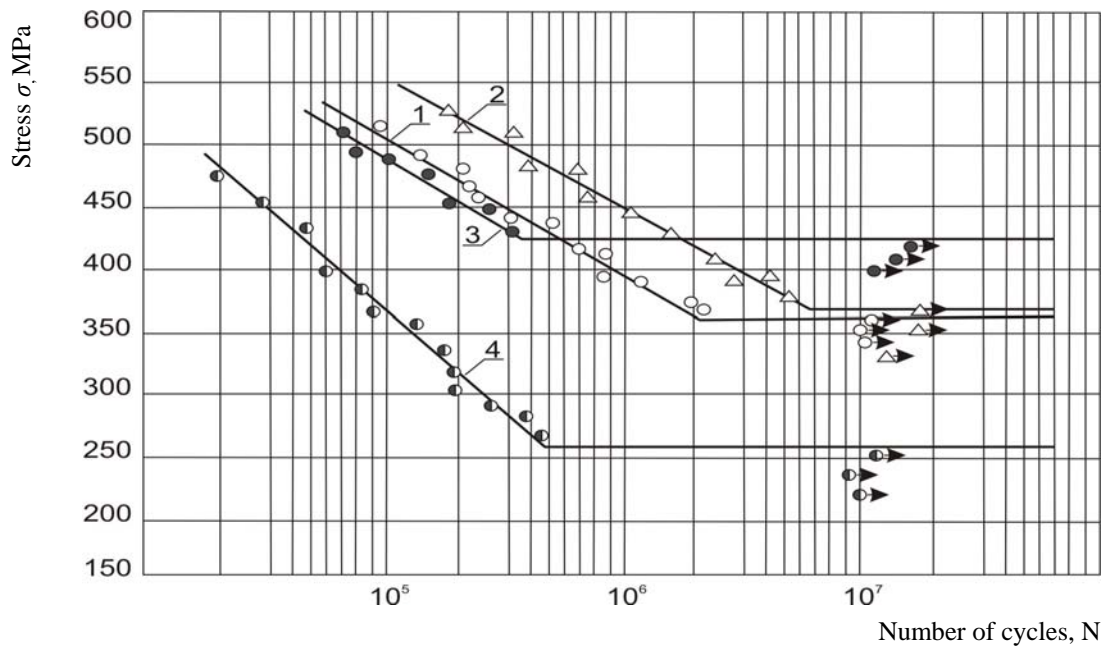

**Fig. 3.** Influence of pyrolytic chromium-plating on fatigue strength of steel: 1 – non plated (origin) steel, 2 – after covering coatings with homogeneous structure, 3 – after covering coatings with horizontal-layered structure, 4 – after covering coatings with columnar (dendritic) structure

investigated material has become considerably worse. It should be noted that increase of fatigue strength of chromium-plated specimens is related with the decrease of microhardness of chromium coating. For example, chromium coating with columnar structure is the hardest (17 000 MPa – 20 000 MPa) and has worst fatigue limit and limited durability. When microhardness of chromium coatings decreases up to 10 000 MPa – 13 000 MPa (coatings with homogeneous or horizontal-layered structures) fatigue strength of the chromium-plated material increases.

## CONCLUSIONS

1. The results of experimental investigations have shown, that after pyrolytic chromium-plating the fatigue strength of investigated steel can be improved as well as considerably worsened. It is due to the fact that depending on operating temperatures of pyrolytic chromium-plating process chromium coatings of different microstructures can be formed.
2. The fatigue tests have shown that in the case of chromium coatings with horizontal-layered structures, the fatigue limit ( $\sigma_{-1}$ ) of investigated steel increased up to 17 % and limited durability almost didn't change in comparison with the original steel. In the case of chromium coatings with homogeneous structure the fatigue limit ( $\sigma_{-1}$ ) didn't change and limited durability increased 3 times in comparison with the original metal.
3. The results of this study have shown that in the case of chromium coatings with columnar (dendritic) structure the fatigue of investigated steel decreased up to 29 %

and limited durability decreased more than 9 times in comparison with the original material.

## REFERENCES

1. **Socha, G.** Experimental Investigations of Fatigue Cracks Nucleation, Growth and Coalescence in Structural Steel *International Journal of Fatigue* 25 (2) 2003: pp. 139 – 147.
2. **Vilys, J., Čiuplys, V., Terentjev, V. F., Kolmakov, A., Kvedaras, V.** Particularities of Plastic Deformation of Metals near Surface Layers. Kaunas: Technologija, 2003: 208 p.
3. **Sun, W. X., Nishida, S., Hattori, N., Usui, I.** Fatigue Properties of Cold-rolled Notched Eutectoid Steel *International Journal of Fatigue* 26 (11) 2004: pp. 1139 – 1145.
4. **Cobo, E. O., Suarez Baldo, R. A., Bessone, J. B.** Corrosion of Chromium Plated Rotor in Drilling Fluid *Surface and Coatings Technology* 122 (3) 1999: pp. 39 – 43.
5. **Hadavi, S. M., Abdollah-Zaden, A., Jamshidi, M. S.** The Effect of Thermal Fatigue on the Hardness of Hard Chromium Electroplatings *Journal of Materials Processing Technology* 147 (3) 2004: pp. 385 – 388.
6. **Nascimento, M. P. and etc.** Effects of Surface Treatments on the Fatigue Strength of AISI 4340 Aeronautical Steel *International Journal of Fatigue* 23 (7) 2001: pp. 607 – 618.
7. **Scmitt-Thomas, Kh. G., Meisel, H., Seßler, W.** Einfluß von beschichtungen auf das schwingung - srißkorrosionsverhalten des Cromstals X20Cr13 *Verstoffe und Korrosion* 37 1986: s. 36 – 44.
8. **Voorwald, H. J. C., Souza, R. C., Pigatin, W. L., Cioffi, M. O. H.** Evaluation of WC-17Co and WC-10Co-4Cr Thermal Spray Coatings by HVOF on the Fatigue and Corrosion Strength of AISI 4340 Steel *Surface and Coatings Technology* 190 (2 – 3) 2005: pp. 155 – 164.