

Studies on Multilayer Nonwovens Containing Flax Fibres Designed for Electromagnetic Radiation Barriers

Marina MICHALAK¹, Izabella KRUCIŃSKA¹, Romuald BRAZIS², Arvydas VITKAUSKAS³, Ewa SKRZETUSKA¹

¹Department of Textile Metrology, Technical University of Lodz, Żeromskiego 116, 94-153 Łódź, Poland

²Semiconductor Physics Institute, A. Goštauto 11, LT-01108 Vilnius, Lithuania

³Department of Textile Technology, Kaunas University of Technology, LT-51424 Kaunas, Lithuania

Received 31 May 2005; accepted 01 July 2005

The barrier properties against electromagnetic radiation of multilayer needle-bonded nonwovens containing flax (F) fibres and polypropylene (PP) fibres and manufactured in different technological conditions have been investigated. Single-fibre webs of longitudinally arranged fibres put into layers one onto another to comprise a multilayer structure of seven single-fibre webs. The number of F fibre webs in the lap influenced the percentage of flax fibres evaluated by mass. Each kind of the laps was needled at the density 80, 120, and 200 cm⁻². As a result, 18 samples of needle-bonded nonwovens of similar morphological and comfort properties but different bulk electrical resistance were prepared. The maximum bulk electrical resistance at dry conditions, of the order of 7·10¹⁴ Ω, was characteristic for the samples made entirely of PP fibres, while the minimum resistance, of the order of 10¹⁰ Ω, was characteristic for the samples made entirely of F fibres. Insert of flax fibres into the nonwoven structure at amount ~14 % resulted in 20 – 100 times decrease of electrical bulk resistance. At the amount of flax fibre ~43 % the electrical resistance at dry conditions was about 200 – 2000 times lower in comparison with the resistance of single PP nonwoven. In spite of such a dramatic change of resistance, none of the samples exhibited barrier properties in the electromagnetic wavelength range from 3.1 mm to 4.3 mm. Further reducing fibre resistance is needed. Fibre arrangement in the nonwovens needs to be optimised, as well. The analysis of the problem is continued.

Keywords: nonwoven, electromagnetic radiation, flax, polypropylene, thermal properties.

1. INTRODUCTION

The problem of electromagnetic field's shielding is at the focus of researchers and preventive institutions during some last decades [1]. Until now, nevertheless, the controversies about possible carcinogenic activity of electromagnetic fields or their effect cardiovascular and nervous systems have not been definitely settled [2, 3].

More and more frequently electromagnetic radiation is dampened with use of textile materials [4, 5]. Electromagnetic barriers based on textiles enriched with silver and other metal wires are subject to broad research and marketing in the Far East and West from Europe [6, 7]. Of late years a wide research on the barrier properties of textile materials against electromagnetic radiation is provided at the Department of Textile Metrology, Technical University of Lodz [8 – 12]. In certain directions of the research the productive collaboration with Lithuanian scientific institutions is proceeding.

The decisive factor determining the barrier property of the material is supposed to be its electric resistance. It has been stated [9, 12] that insertion 0,5 % of electroconductive fibre to the nonwoven structure of polypropylene (PP) fibre resulted in increase of bulk and surface conductivities of nonwoven by seven orders of magnitude. Moreover, it has been shown that it is possible to increase the bulk conductivity of nonwoven by the proper arrangement of lap layers at the same percentage of conductive fibres in a blend.

In [8, 10, 11] it has been shown that hemp fibre as well as chemically modified electroconductive fibres possess the ability to damp electromagnetic radiation in a wide range of frequencies, and therefore can be successfully used in barrier materials against electromagnetic radiation.

Present work is focused on the investigation of analogous multi-layer structures comprising of polypropylene (PP) and flax fibres.

2. EXPERIMENTAL

2.1. The materials studied

Single-fibre webs of longitudinally arranged PP and flax fibres were mechanically prepared. The webs were put into layers one onto another to comprise a multilayer structure of seven single-fibre webs. The flax fibre used for the layers was obtained in the loose state, natural colour and various level of contamination. Originated from flax plants grown in the districts of Lithuania, it was dew-retted, then hackled on the hackling machine AchL of former USSR. This resulted in 38.6 % of hackling tow No6 which was further processed on the carding aggregate A-150 L3 and treated mechanically to elementarize the fibres.

Linear density of the flax fibre measured according to the Polish standard BN-86/7511-16 was 35.8 dtex with the coefficient of variation 17,6 %. Distribution of the flax fibre in length measured according to Polish standard PN-7511-16 is shown in Fig. 1. It is seen that 60 % of fibres are of 65 mm in length.

Linear density (7 dtex, coefficient of variation 4.8 %) and cutting length (60 mm) of polypropylene fibre were chosen to fit as possibly to those of flax fibre.

*Corresponding author. Tel.: +48-42-6313313; fax: +48-42-6313318.
E-mail address: marina@mail.p.lodz.pl (M. Michalak)

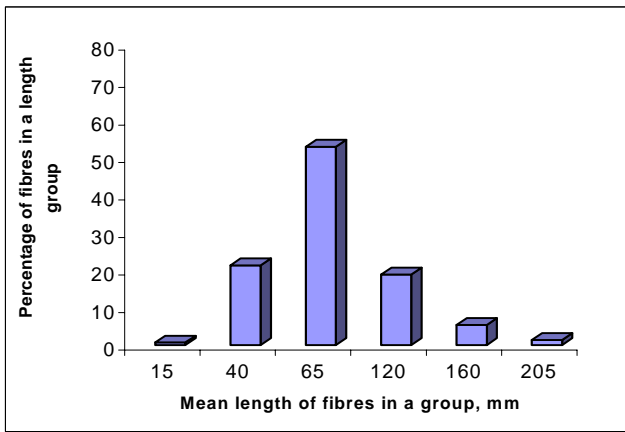

Fig. 1. Distribution in length of the flax fibre

Each kind of the laps was needed at the density 80, 120, and 200 cm^{-2} (Table 1). As a result, 18 lap samples of needle-bonded nonwovens comprised of 7 layers with the different fibre composition and differently arranged were obtained.

Table 1. Fibre composition and arrangement of layers of the nonwoven laps^{*)}

| No | The code of the nonwoven | Arrangement of the layers | Percentage of flax fibre, % /Number of flax fibre layers | Number of needlings, cm^{-2} |
|----|--------------------------|---------------------------|--|---------------------------------------|
| 1 | PP/80 | ppppppp | 0/0 | 80 |
| 2 | PP/L/80/1 | pppfppp | 14,28/1 | 80 |
| 3 | PP/L/80/3 | ppffppp | 42,85/3 | 80 |
| 4 | PP/L/80/3a | pfpfppp | 42,85/3 | 80 |
| 5 | PP/L/80/3b | fppfppp | 42,85/3 | 80 |
| 6 | L/80 | ffffff | 100/7 | 80 |
| 7 | PP/120 | ppppppp | 0/0 | 120 |
| 8 | PP/L/120/1 | pppfppp | 14,28/1 | 120 |
| 9 | PP/L/120/3 | ppffppp | 42,85/3 | 120 |
| 10 | PP/L/120/3a | pfpfppp | 42,85/3 | 120 |
| 11 | PP/L/120/3b | fppfppp | 42,85/3 | 120 |
| 12 | L/120 | ffffff | 100/7 | 120 |
| 13 | PP/200 | ppppppp | 0/0 | 200 |
| 14 | PP/L/200/1 | pppfppp | 14,28/1 | 200 |
| 15 | PP/L/200/3 | ppffppp | 42,85/3 | 200 |
| 16 | PP/L/200/3a | pfpfppp | 42,85/3 | 200 |
| 17 | PP/L/200/3b | fppfppp | 42,85/3 | 200 |
| 18 | L/200 | ffffff | 100/7 | 200 |

^{*)}p – polypropylene web; f- flax web; PP/L – heterogeneous polypropylene-flax nonwoven; PP – single polypropylene nonwoven; L – single flax nonwoven.

2.2. Testing methods

Electrical properties of the fibres, morphological and physical features of nonwovens as well as electromagnetic wave attenuation were investigated. Furthermore, considering the possibility of the following studies of the prepared

material the thermal conductivity in the infrared range was also measured. All the features of the fibres and nonwovens were tested according to the Polish standards: PN-86/P-04761/03, PN-EN 29073-1, PN-89/P-04618, PN-91/P-04871. Before the measurements the testing samples were conditioned in standard atmospheres.

The electric resistance of the nonwovens were measured in perpendicular (transverse resistance) directions to the nonwoven plane using the special electrodes. In order to reduce errors arising in the evaluation of the material resistivity the values of electrical resistance read directly from the measuring device are analysed in the study. The mean values of resistance were calculated from 15 measurements.

The multifunctional Alambet instrument [13] was used to measure thermal absorption b (in $\text{W}\cdot\text{s}^{1/2}\cdot\text{m}^{-2}\text{K}^{-1}$), and heat resistance r (in $\text{K}\cdot\text{m}^2/\text{W}$) of the nonwovens.

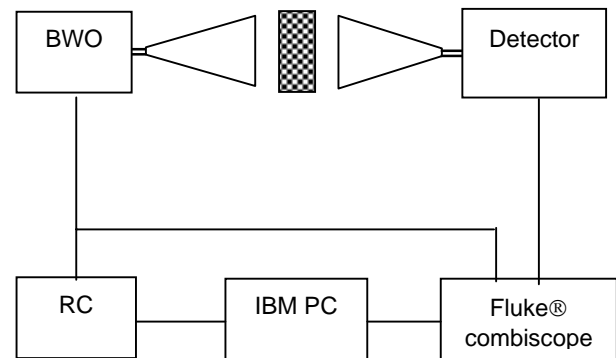

Fig. 2. Microwave set-up scheme

Microwave transmission has been experimentally studied using the techniques described in [14] and outlined in Fig. 3. The set-up comprised of the backward-wave oscillator (BWO) with the waveguide output to the horn antenna, and the identical receiving antenna collecting the radiation to the point detector positioned on the way to matched load at a waveguide end. The wave frequency has been tuned by the discharge of condenser via the RC chain including the anode circuit of the BWO, and the anode voltage has been registered by a digital Fluke® combiscope. The range of wavelength control has been relatively narrow (31 mm ÷ 43 mm) determined by the BWO construction addressed initially to radar applications. Data acquisition system included IBM PC with the programme completed with the beforehand-prepared BWO and detector calibration routines.

Textile sample has been positioned freely between the horn antennas and the dependence of the transmitted power P_1 on the wave frequency has been measured. Transmission coefficient T has been defined as the ration of P_1/P_0 where P_0 is the reference power transmitted through the empty system (without the sample). Wave electric field polarisation in the vertical plane has been determined by the TE_{10} mode selection in the 10×23 mm metal waveguide. This enabled us to check the anisotropy of attenuation of textiles by turning the sample in its plane (around the axis that is parallel to the wave propagation direction).

3. RESULTS AND DISCUSSION

The measured data of area density M_p , thickness d , bulk density ρ and air permeability P_p of the investigated samples of nonwovens are presented in Table 2.

Table 2. Morphological properties and air permeability of the nonwovens

| Nonwoven | M_p , g/m ² | d , mm | ρ , g/cm ³ | P_p , dm ³ /(m ² ·s) |
|-------------|-----------------------------|-------------|-------------------------------|---|
| PP/80 | 197.96 | 4.87 | 0.0382 | 1219.75 |
| PP/L/80/1 | 194.25 | 4.72 | 0.0393 | 993.53 |
| PP/L/80/3 | 199.26 | 4.73 | 0.0394 | 1109.70 |
| PP/L/80/3a | 204.27 | 4.76 | 0.0378 | 1095.94 |
| PP/L/80/3b | 196.43 | 4.70 | 0.0363 | 1033.27 |
| L/80 | 172.36 | 3.91 | 0.0397 | 1637.03 |
| PP/120 | 190.19 | 4.38 | 0.0434 | 970.60 |
| PP/L/120/1 | 190.93 | 4.62 | 0.0414 | 868.19 |
| PP/L/120/3 | 194.89 | 4.40 | 0.0423 | 1042.44 |
| PP/L/120/3a | 191.14 | 4.39 | 0.0407 | 996.59 |
| PP/L/120/3b | 186.20 | 4.67 | 0.0398 | 993.53 |
| L/120 | 163.71 | 3.80 | 0.0431 | 1578.95 |
| PP/200 | 186.20 | 3.81 | 0.0519 | 799.34 |
| PP/L/200/1 | 185.70 | 4.44 | 0.0428 | 855.96 |
| PP/L/200/3 | 186.31 | 4.08 | 0.0487 | 987.42 |
| PP/L/200/3a | 180.26 | 3.80 | 0.0483 | 956.85 |
| PP/L/200/3b | 170.74 | 4.07 | 0.0439 | 918.63 |
| L/200 | 155.21 | 3.52 | 0.0489 | 1403.17 |

According to PN-91/P04871 the bulk electrical resistance was measured for fibres as well as for nonwovens. The average electrical resistance of polypropylene fibres was found to be $4.1 \cdot 10^{12} \Omega$ while the resistance of flax fibres was $2.06 \cdot 10^9 \Omega$, or 2000 times lower than that of PP fibres. For flax fibres substantially lower was also the resistance data scattering: coefficient of variation for flax fibres was 3.3 % against 21.7 % for PP fibres.

The test results of electrical resistance for all of nonwovens variants is presented in Table 3. Resistance was observed to increase with increase of sample thickness independently of fibre constitution. The data of measurements conducted on dry conditions, that means at $22^\circ\text{C} \pm 2^\circ\text{C}$ and 24 % humidity, are marked by index “s” whereas those obtained at temperature of $20^\circ\text{C} \pm 2^\circ\text{C}$ and 67 % humidity are referred to “wet” and marked by index „w”, that means R_s and R_w , correspondingly. Table 3 presents also the measured thermal absorption b and heat resistance r .

The electrical resistance of investigated nonwovens depends on blending ratio, on the resistivity of constituent fibres as well as on the ambient air temperature and humidity. The latter dependence is more pronounced for the high-flax-percentage nonwovens. Measurements provided on low-flax-percentage samples (e.g. PP/L/80/1) showed higher electric resistance both in dry and wet conditions, as compared to that in high-flax-percentage samples (e.g. PP/L/80/3b).

From the presented results it also follows that the way of fibre web arrangement in the lap influences the electrical resistance of nonwoven. At identical fibre percentage, the electric resistance is lower in those nonwovens that comprise of layer webs arranged alternately but not concentrated inside or outside the lap. It can be also noticed that increase in a number of needlings results in decrease of the nonwoven’s electrical resistance. It can be related to the needling-induced transverse interconnections by the lower-resistance fibres, as well as to the tighter arrangement of the fibres ensuring more inter-fibre contacts per unit volume and a collapse of the air space in the nonwoven.

Table 3. The electrical resistance of nonwovens in dry and wet conditions and the results of thermal absorption and heat resistance

| Nonwoven | R_s , Ω | R_w , Ω | b , W·s ^{1/2} /(m ² ·K) | r , K·m ² /W |
|-------------|----------------------|----------------------|--|------------------------------|
| PP/80 | $7.2 \cdot 10^{14}$ | $1.65 \cdot 10^{13}$ | 46.9 | 118 |
| PP/L/80/1 | $3.98 \cdot 10^{13}$ | $1.14 \cdot 10^{12}$ | 42.3 | 113 |
| PP/L/80/3 | $3.15 \cdot 10^{12}$ | $4.00 \cdot 10^{10}$ | 43.5 | 111 |
| PP/L/80/3a | $4.8 \cdot 10^{11}$ | $1.60 \cdot 10^{10}$ | 45.5 | 112 |
| PP/L/80/3b | $4.83 \cdot 10^{11}$ | $1.65 \cdot 10^{10}$ | 45.3 | 114 |
| L/80 | $1.97 \cdot 10^{10}$ | $3.10 \cdot 10^8$ | 46.4 | 83.3 |
| PP/120 | $6.5 \cdot 10^{14}$ | $1.00 \cdot 10^{13}$ | 52.6 | 111.1 |
| PP/L/120/1 | $1.25 \cdot 10^{13}$ | $7.80 \cdot 10^{11}$ | 51.5 | 102 |
| PP/L/120/3 | $1.7 \cdot 10^{12}$ | $8.60 \cdot 10^9$ | 49.3 | 103 |
| PP/L/120/3a | $3.75 \cdot 10^{11}$ | $1.11 \cdot 10^{10}$ | 49.7 | 107.2 |
| PP/L/120/3b | $3.6 \cdot 10^{11}$ | $1.50 \cdot 10^{10}$ | 48.7 | 109.3 |
| L/120 | $1.5 \cdot 10^{10}$ | $2.60 \cdot 10^8$ | 47.0 | 69.2 |
| PP/200 | $5.45 \cdot 10^{14}$ | $5.30 \cdot 10^{12}$ | 53.9 | 108 |
| PP/L/200/1 | $4.7 \cdot 10^{12}$ | $5.50 \cdot 10^{11}$ | 58.2 | 101 |
| PP/L/200/3 | $5.9 \cdot 10^{11}$ | $3.80 \cdot 10^9$ | 53.0 | 102 |
| PP/L/200/3a | $2.2 \cdot 10^{11}$ | $8.40 \cdot 10^9$ | 54.6 | 91.8 |
| PP/L/200/3b | $1.83 \cdot 10^{11}$ | $6.10 \cdot 10^9$ | 55.5 | 95.6 |
| L/200 | $8.4 \cdot 10^9$ | $2.30 \cdot 10^8$ | 54.6 | 64.5 |

The thermal properties data show slight dependence of thermal absorption and heat resistance on the flax fibre percentage within the group of the same needling density. However, increase in the needling density results in the increase of thermal absorption and in the decrease of heat resistance. Such dependence means that the needling density plays the major role in the phenomena of heat transfer and absorption than the bulk density of the lap.

Research on the experimental set-up described in Section 2 has shown that the electromagnetic wave transmission coefficient is near to 100 % in all the samples. This is the result essentially different from that obtained in [8] where the attenuation has been measured in textiles comprising of hemp fibre blends. Transmission coefficient has been found there to be up to 40 % in some blend compositions at the frequency of 13 GHz. It has been found that the hemp-based textile attenuation increases essentially with the probe humidity. In the present work, the barrier properties of flax-based textiles have been studied at nominally dry conditions. Although the flax belongs to the same

group of bast fibres its ability to adsorb water molecules can be different from that in hemp. Having no data on humidity we state just the fact of the reduction of probe resistance by orders of magnitude due to the increase of the flax contents. On the background of the dramatic reduction of resistance the lack of noticeable change of transmission seems astonishing. The reason for such an output could be still too high specific effective resistance of the tested layered textile structures at microwaves. The research will be repeated at probes acclimatised at humid atmosphere. The guideline for the further research on the textile barriers of electromagnetic radiation is presented in Fig. 3 borrowed from the previous work [14].

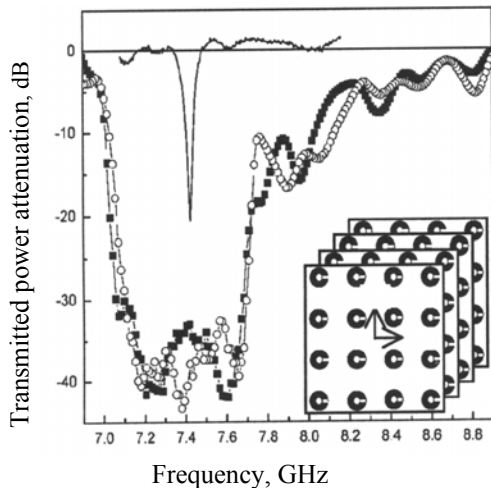

Fig. 3. Photonic crystal assembled from the split copper rings (insert) and the transmitted power attenuation as function of frequency for the wave propagating along (dots) and against (circles) the binary axis. In the upper insert the resonance line of a single split ring is presented. The ring wire diameter is 0.54 mm, the inner diameter of the ring is 4.5 mm, the slit is 0.6 mm, and the crystal lattice constant is between 10 mm to 12 mm [14]

The barrier of transmission in the range from 7.3 GHz to 7.8 GHz has been obtained there in the 3-dimensional array of small (compared to the wavelength) split copper rings on thin polymer foils suspended in air. One can expect that conductive fibre entanglement so as to create loops will result in improving barrier properties of textiles.

3. CONCLUSIONS

The measured parameters of thermal and electric resistance depend on the technology of produced textiles. The admixture of flax fibres to the textiles fabricated from the polypropylene fibres results in significant (over 3 orders of magnitude) decrease of the blend resistance. This is the feature favourable to applications preventing static electricity accumulation. However, textile samples investigated in this work turned out to present no barriers for electromagnetic radiation in the wavelength range of 3.1 mm to 4.3 mm. Further reduction of the specific resistance is needed. Moreover, fibre arrangement in the textile structure needs to be optimised. Judging from spectacular bands of attenuation observed in photonic crystals assembled from the small split copper rings, one can expect that the barrier properties of textiles will improve essentially due to

loops created from electrically conductive fibres. The loop arrangement in a proper symmetry is the way of barrier positioning in a desired frequency bands. The investigations are continued.

REFERENCES

1. NSA-65-6. National Security Agency Specification for R.F. Shielded Enclosures for Communication Equipment: General Specification. National Security Agency, USA, 1964.
2. Savitz, D. A., Wachtel, H., Barnes, F. A., John, E. M., Tvrdik, J. G. Case-Control Studies of Childhood Cancer and Exposure to 60 Hz Magnetic Fields *American Journal of Epidemiology* 128 (1) 1988: pp. 21 – 38.
3. Freude, G., Ullspreger, P., Eggert, S., Ruppe, I. Microwaves Emitted by Cellular Telephones Affects Human Slow Brain Potentials *European Journal of Applied Physiology* 81 (1 – 2) 2000: pp. 18 – 27.
4. Chodakova, I. N., Akulicz, T. B., Tchibisowa, T. B. Multilayer Nonwovens Designated for Electromagnetic Radiation Protection *III Symposium EL-TEX'98, Łódź, 24 – 25 November 1998*: pp. 188 – 195.
5. Vogel, Cz., Haase, J. Comparative Tests of Electrostatic and Electromagnetic Behaviour of Typical Nonhomogeneous Electroconductive Textile Products *III Symposium EL-TEX'98 Łódź, 24 – 25 November, 1998*: pp. 89 – 94.
6. Koch, M., Kamp, M., Kebel, R. Sturdy Textile Shielding Covers for Field Operations and Protection of COTS Equipment. EMW, BAKWVT Mannheim, 2002.
7. <http://www.asiaprofile.com/exportimport/textile5.html>
8. <http://www.knwool.co.kr/eng/textile/develop.asp>
9. <http://www.ntcresearch.org/pdf-rpts/AnRp04/M04-GT19s-A4-proposal.pdf>
10. Brazis, R., Czekalski, J., Kozakiewicz, D., Michalak, M., Stasiak, M. Electromagnetic Wave Attenuation in Hemp-PAN Fibre Blends, *Fibres & Textiles in Eastern Europe* 8 (2) 2000: pp. 35 – 38.
11. Michalak, M., Bilaska, J., et al. The Research on the Design of Nonwovens for Electromagnetic Radiation Barriers *VII International Scientific Conference "Nauka a Jakość Życia (Science and the Living Standards)"* Vilnius, Lithuania, June 2002, Studium Vilnense, 2002: pp. 323 – 326.
12. Michalak, M., Krucińska, I., Brazis, R. The Barrier Properties of Textile Fabrics Containing Hemp Fibres *V International Symposium EL-TEX 2002 Łódź, Poland, November 2002*, pp.45-54 (in Polish).
13. Michalak, M., Kozakiewicz, D., Czekalski, J., Brazis, R. Electromagnetic Wave Attenuation in Ecological Textiles Containing Hemp Fibres *Materials Science (Medziagotyra)* 8 (3) 2002: pp. 311 – 315.
14. Michalak, M., Bilaska, J. Multi-Layer Structures of Attenuating Properties *International Conference "Baltic Textile & Leather"* Kaunas-Vilnius, Lithuania, September 11-12, 2003: pp. 39 – 44.
15. Frydrych, I., Porada, A., Bilaska, J., Konecki, W. The Thermal Insulation Parameters of Fabrics *Przegląd Włókienniczy (Textile Revue)* 10 2003: pp. 12 – 15.
16. Liniuskas, A., Brazis, R. Photonic Crystal Assembled from Non-magnetic Wire Split Rings *Applied Physics Letters* 85 (2) 2004: pp. 338 – 340.

DOI: 10.5755/j02.ms.26406