

Determination of Metal Surface Hardened Layer Depth Using Magnetic Barkhausen Noise

Vygantas AUGUTIS¹, Ramūnas RAMANAUSKAS¹, Antanas ČIUPLYS²,
Jonas VILYS^{2*}, Vytautas ČIUPLYS²

¹*Department of Electronics and Measurements Systems, Kaunas University of Technology,
Studentų 50, LT-51368, Kaunas, Lithuania*

²*Department of Metals Technology, Kaunas University of Technology, Kęstučio 27, LT-44025 Kaunas, Lithuania*

Received 31 January 2005; accepted 30 April 2005

Radiography, microhardness measurements, residual stress distribution curves, decoding of dislocations, metallographic methods, method of different etching rate of the stressed and not stressed areas of crystal, and others are used at present for determination of metals plastic deformation locality. All these methods are long-term, labour consuming and rather inaccurate. The purpose of the work was to develop reliable and rapid non-destructive durable method of hardened layer depth measuring using magnetic Barkhausen noise. The tests showed that using this method it is possible to determine the depth of hardened surface layer at accuracy of 0.01 mm.

Keywords: magnetic Barkhausen noise, non-destructive testing, metal, hardened surface layer, residual stress.

1. INTRODUCTION

Investigation of an effect of near surface layer on the physical-mechanical properties and heterogeneity of plastic deformation of metals sometimes meets the difficulties related to the determination of the depth of that layer and local character of stress distribution in that layer, especially in the range of small strains. The live issue is the problem of rapid and precise depth determination of the hardened subsurface layer during special process. Radiography, microhardness measurements, residual stress distribution curves, decoding of dislocations, metallographic methods, method of different etching rate of the stressed and not stressed areas of crystal, and others are used at present for determination of these characteristics [1, 2]. However, all these methods are long-term, labour consuming and rather inexact. Taking this into consideration the problem of development of reliable and rapid method of determination of above mentioned characteristics arises.

The plastically deformed metal in the prestrained layer, differently than not strained parent metal, is characterized by high concentration of microdefects, such as motionless dislocations, vacancies of atoms of an interference and their interaction, which restricts their mobility, and results metal hardening during prestrain. It increases magnetic properties of steel which can be measured by magnetic Barkhausen noise [3].

Magnetic Barkhausen noise (MBN) is a phenomenon that occurs when a ferromagnetic material is subjected to an alternating external magnetic field which induces discontinuous changes in its magnetization. All ferromagnetic materials have a domain structure with different magnetization regions polarized in one direction and separated by Bloch walls [3]. When a magnetic field is applied to ferromagnetic materials, the increase in flux

density takes place in a discontinuous manner as a result of magnetic domain walls rotation and breaking away from their original positions. These sudden changes in the magnetization result in micro eddy-currents, which can be picked up by a coil, placed near the surface of the material, as a noise signal.

The MBN has been shown to be sensitive to many material properties, such as grain size, composition of the material, hardness, residual tension and fatigue [4 – 6]. For this reason, MBN has been studied as a potential tool for non-destructive measurement of metallurgical, microstructural and mechanics parameters.

The study is based on the analysis of the power spectrum of MBN. Usual MBN sensors contains with magnetizing system a pickup coil that is placed at the surface of the test material. Some MBN transducers have an auxiliary coil for measure magnetizing flux. However, these transducers do not appreciate influence of test material on measurement circuit (measurement coil inductance, therefore frequency characteristics, depend on sample geometric and magnetic properties).

In MBN transducers, that we propose, additional calibration coil is placed, which allows estimation of frequency response of measurement channel beside on the testing object. In this way it is possible to measure MBN spectrum, which allows appreciating information from the different materials layers. The depth of examination is given by the analyzing frequency because high-frequency events are mainly received from the subsurface regions and low-frequency events originate from deeper regions of the sample under investigation.

The depth of the measurements depends on the frequency of the excitation [7], but typically for MBN it is in the range of 0.1 mm – 1 mm.

The purpose of our work was to develop non-destructive method of hardened layer depth measuring using magnetic Barkhausen noise.

*Corresponding author. Tel.: +370-37-300420; fax: +370-37-323461.
E-mail address: ojvilys@one.lt (J. Vilys)

2. EXPERIMENTAL

2.1. Samples

The samples of low-carbon steel were used for the experiments. The chemical composition of steel is shown in Table 1.

Table 1. Chemical composition of low-carbon steel

C, %	Si, %	Mn, %	Cr, %	P, %	S, %
0.18	0.2	0.45	0.15	0.035	0.040

Samples (15 × 100 mm) were cut out from the sheet of steel (sheet thickness 4 mm). In order to equalize the surface and align contortions, which appeared after cutting, the samples were mechanically polished from both sides. The final thickness of the samples was 3.5 mm. In order to remove some residual stresses, which appeared after polishing, the samples were annealed in vacuum of $2 \cdot 10^{-2}$ Pa at the temperature of 875 °C during 90 minutes. The microstructure analysis has shown that grains of equal axes with the average diameter of which 35 μm were typical for the investigated specimens.

2.2. Magnetic Barkhausen noise measurement

The MBN measuring system (Fig. 1) consists of these basic units:

- the magnetizing system consisting of a sine generator and a magnetising coil;
- the unit for detecting Barkhausen noise voltage signals consisting of a detecting coil, a signal amplifier and a band-pass filter;
- the digitalization unit – an oscilloscope Agilent 54622A;
- the unit for processing, evaluation and analysis of (digitized) voltage signals – personal computer and MATLAB software.

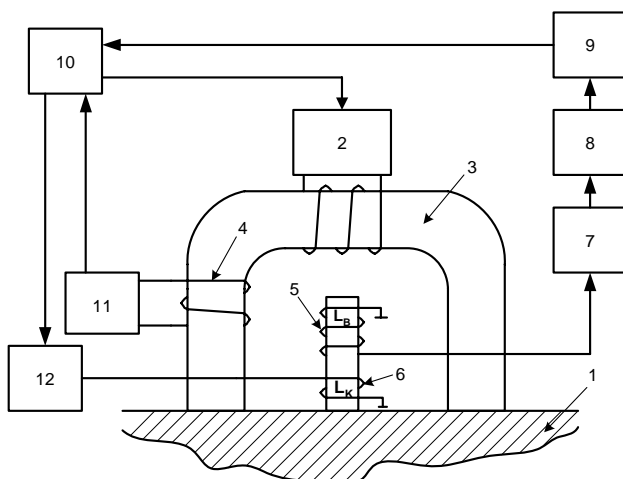
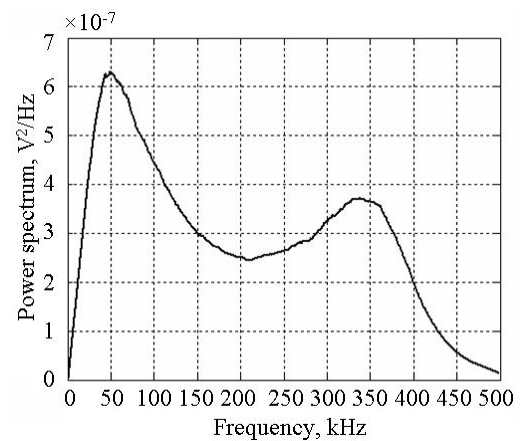
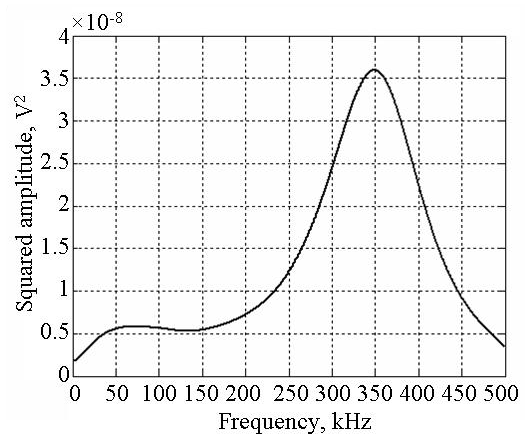

Fig. 1. Barkhausen noise measuring scheme: 1 – sample; 2 – waveform generator; 3 – U core electromagnet; 4 – auxiliary coil for excitation field measurement; 5 – MBN measurement coil; 6 – calibration coil; 7 – amplifier; 8 – digital oscilloscope Agilent 54622A; 9 – PC; 10 – controller; 11 – excitation field measurement unit; 12 – generator of calibration impulses



a



b

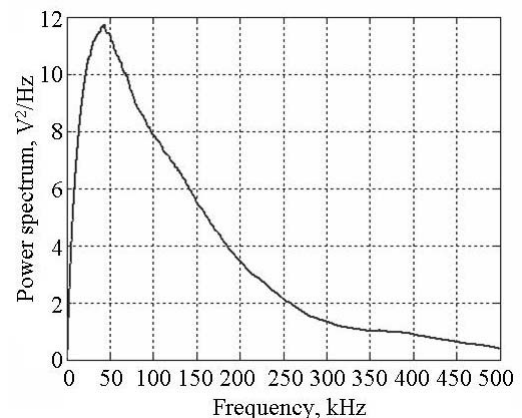

c

Fig. 2. Calculation of certain MBN spectrum in specimen (Calibration procedure): $c = a / b$; a – MBN signal spectrum without calibration ($FT[U_B(t)]$); b – frequency response of a measurement channel ($K_{HU}(j\omega)$); c – MBN signal spectrum after calibration ($S_H(j\omega)$)

The test object 1 is periodically magnetized by an alternating magnetic field, generated by a U-shaped electromagnet 3. The magnetising frequency was 50 Hz. The Barkhausen noise signal is detected by a magnetoinductive transducer (pickup coil) that is placed at the surface of the test material between the poles of the electromagnet 5. Separation of the noise signal from the exciting field signal and its higher harmonics requires frequency filtering and amplification 7. Finally, it is

digitized and monitored using an Agilent 54622A oscilloscope 8 (with a sampling frequency of 200 MHz) and captured to a computer 9. To eliminate influence of pickup coil and sample interaction to the measurement channel a calibration was needed. During calibration process, calibration coil 6 was excited by δ impulse and impulse response and therefore frequency response of the measurement channel was obtained. The analysis of voltage signals was achieved using MATLAB FFT routines. Spectrum of a certain MBN in specimen was attained dividing captured from detecting coil MBN voltage signal spectrum by squared frequency response of the measurement channel (Fig. 2):

$$S_H(j\omega) = \frac{FT[U_B(t)]}{K_{HU}(j\omega)} \quad (1)$$

Ten series for each sample were performed and averaged. This procedure guarantees the reproducibility of obtained results.

2.3. Determination of residual stresses

A simple portable device (Fig. 3) to define residual stresses of the first kind was developed. This device measures the size and signs of the stresses in a cross-section of laminated samples with a high degree of accuracy.

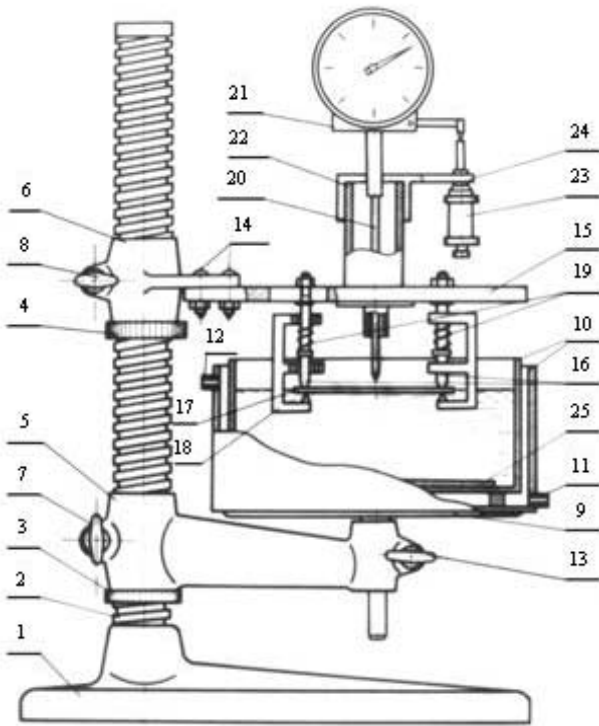

Fig. 3. Schematic diagram of the device for determination of residual stresses

The device consists of the basis 1, in which the screw 2 is pressed. The rectangular groove of this screw through the nuts 3 and 4 provides free motion of arms 5 and 6 along its axis. The motionless fastening of the arms is carried out by screws 7 and 8. The table 9 for the vessel with double walls 10 on the arm 5 is fixed. In an external wall of a vessel 10 the inlet 11 and the outlet branch pipe 12. The table 9 has axis of rotation fixed by a screw 13.

The plate 15 is fastened to the arm 6 by bolts 14. In the guides of the plate two sliding support 16 are mounted. They can be positioned according to the length of a sample 17. The specimen is fixed by clips 18 and springs 19. The leg 20 of the indicator 21 is moved in guides 22 by the micrometric screw 23. The micrometric screw together with the indicator 21 is fastened to the holder 24. During the electrolytic etching the metal sample 17 serves as the anode, and the stainless steel plate 25 of lowered on the bottom of a bath serves as cathode.

This device was used to determine the size and sign of residual stresses of the first kind, which appears after hardening of the subsurface layer of a laminated sample. The lateral sides of the sample were covered with resistance acid varnish. The vessel was filled with electrolyte until 3/4 parts of vessel volume. The sample was put in electrolyte on the depth not exceeding 1/3 part of its thickness. Chemical composition of the electrolyte: 850 ml H_3PO_4 + 150 ml H_2SO_4 + 50 g CrO_3 . The temperature of electrolyte was 20 °C. The big volume of electrolyte (5 l), continuous mixing and water cooling provided stability of temperature in the zone of etching in the range of 1 °C. Such small alteration of the temperature hasn't any effect on deflection of the sample. Measurements of the deflection were made at the given intervals of time corresponding to certain depths of etched layer. They were made in the central part of a sample by means of the indicator, which value of division was 1 μm . When electrolytic etching was finished, the sample was washed together with the device in a bath with water.

The thickness of removed layer in the process of electrolytic etching was calculated by use the curve describing the relationship between the time of etching and thickness of a removed layer at constant density of electric current, temperature of etching and electrolyte composition. Then the total thickness of all removed layers

$(\sum_0^N \Delta\delta_N)$ was determined by the method of weighing

according the relationship:

$$\sum_0^N \Delta\delta_N = \frac{\Delta P}{ab\rho}, \quad (2)$$

where $\Delta\delta_N$ is thickness of N -th etched from surface sample layer; ΔP is loss of weight of a sample as a result of etching; a is length of a sample; b is width of a sample; ρ is density of a material.

Weight of etched material was determined with accuracy of 0.0001 g. The thickness of the removed layers was roughly inspected also with the micrometer.

On the basis of the received data on deformation of a sample and the thickness of etched layer, the expected value and the sign of residual stresses $\sigma(a)$, acting on the distance a from the top side of a sample were calculated, according to the relationship [8]:

$$\sigma(a_i) = \frac{4E}{3l^2} \left[(h - a_i)^2 \frac{(f_{i+1} - f_{i-1})}{2(a_i - a_{i-1})} - 4(h - a_i)f(a_i) \right], \quad (3)$$

where E is the modulus of elasticity of a material; l is the length of a sample; h is the thickness of a sample; f is the deflection in the central part of a sample.

3. RESULTS AND DISCUSSION

The plate shape samples of low-carbon steel were hardened by rollers. There were made two sets of the samples with various depth of hardened surface layer. All experiments were run at room temperature. The samples of the first set were measured using MBN, and residual stresses of samples of the second set were defined. The data of measurements are shown in Figures 4 and 5.

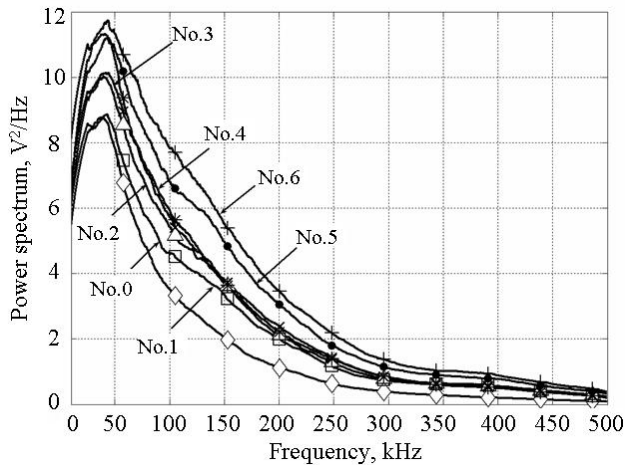

Fig. 4. Power spectrum of MBN in different samples

According to the distribution of residual stresses in samples' surface (Fig. 5), we can exactly determine the depth of hardened surface layer: 0 – not hardened sample, 1 – the depth of hardened surface layer 0.18 mm, 2 – 0.38 mm; 3 – 0.4 mm, 4 – 0.7 mm; 5 – 0.85 mm; 6 – 0.86 mm.

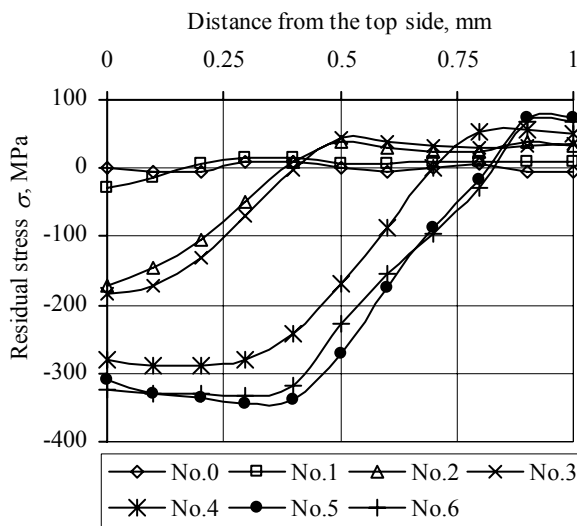

Fig. 5. Distribution of residual stresses in subsurface layer of the samples after various degrees of hardening: No. 0 – 6 – number of the sample (0 – not hardened, 1 – the depth of hardened surface layer 0.18 mm, 2 – 0.38 mm; 3 – 0.4 mm, 4 – 0.7 mm; 5 – 0.85 mm; 6 – 0.86 mm)

Comparing results obtained by Barkhausen method it is noticed that increasing depth of hardened surface layer proportional increases the value of MBN spectrum maximum. When the sample is not hardened, the value of

MBN spectrum maximum is $8.77 \text{ V}^2/\text{Hz}$, and when the depth of hardened surface layer is 0.86 mm, the value of MBN spectrum maximum is $11.74 \text{ V}^2/\text{Hz}$.

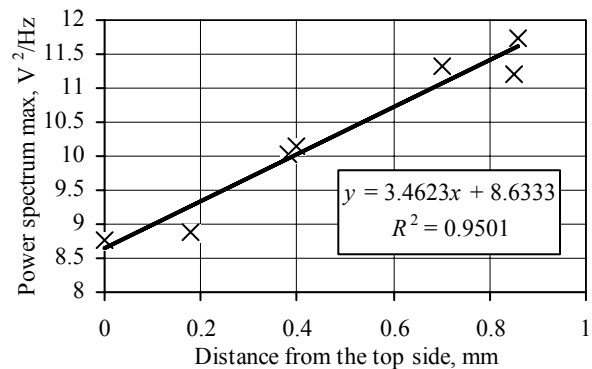

Fig. 6. Dependence of value of MBN spectrum maximum on the depth of the hardened surface layer

Figure 6 shows the dependence of value of MBN spectrum maximum on the depth of hardened surface layer.

In accordance with given data it's true to say that using MBN spectrum it is possible to determine the depth of the hardened surface layer with accuracy of 0.01 mm. The measurement is fast and non-destructive.

4. CONCLUSIONS

1. Original, non-destructive hardened layer depth measuring method, based on Barkhausen effect, is developed.
2. Using this method it is possible to determine the depth of hardened surface layer with accuracy of 0.01 mm.

REFERENCES

1. Polyak, M. Strengthening Technology. Vol. 1. Moscow, Mashinostrojenie 1995: 832 p. (In Russian).
2. Polyak, M. Strengthening Technology. Vol. 2. Moscow, Mashinostrojenie 1995: 688 p. (In Russian).
3. Kroning, M., Haussler, F., Arnold, W. Surface Analysis by Non-destructive Testing Techniques *Fresenius J. Anal. Chem.* 358 1997: pp. 3 – 9.
4. Anglada-Rivera, J., Padovese, L. R., Capo-Sanchez, J. Magnetic Barkhausen Noise and Hysteresis Loop in Commercial Carbon Steel: Influence of Applied Tensile Stress and Grain Size *J. Magn. Magn. Mater.* 231 2001: pp. 299 – 306.
5. O'Sullivan, D., Cotterell, M., Cassidy, S., Tanner, D.A., Meszaros, I. Magneto-acoustic Emission for the Characterisation of Ferritic Stainless Steel Microstructural State *J. Magn. Magn. Mater.* 271 2004: pp. 381 – 389.
6. Ng, D.H.L., Cho, K.S., Wong, M.L., Chan, S.L.I., Ma, X.-Y., Lo, C.C.H. Study of Microstructure, Mechanical Properties, and Magnetization Process in Low Carbon Steel Bars by Barkhausen Emission *Materials Science and Engineering A* 358 2003: pp. 186 – 198.
7. Hartmann, K., Moses, A.J., Meydan, T. A System for Measurement of AC Barkhausen Noise in Electrical Steels *J. Magn. Magn. Mater.* 254 – 255 2003: pp. 318 – 320.
8. Vilyis, J., Čiuplys, V., Terentjev, V., Kolmakov, A., Kvedaras, V. Particularities of Plastic Deformation of Metals near Surface Layers. Kaunas, Technologija, 2003: 208 p.

DOI: 10.5755/j02.ms.26409