

Mono Composite Leaf Spring for Light Weight Vehicle – Design, End Joint Analysis and Testing

Gulur Siddaramanna SHIVA SHANKAR*, Sambagam VIJAYARANGAN

Mechanical Engineering Department, PSG College of Technology, Coimbatore-641004, India

Received 20 June 2005; accepted 07 April 2006

The automobile industry has shown increased interest in the replacement of steel spring with fiberglass composite leaf spring due to high strength to weight ratio. Therefore; the aim of this paper is to present a low cost fabrication of complete mono composite leaf spring and mono composite leaf spring with bonded end joints. Also, general study on the analysis and design. A single leaf with variable thickness and width for constant cross sectional area of unidirectional glass fiber reinforced plastic (GFRP) with similar mechanical and geometrical properties to the multileaf spring, was designed, fabricated (hand-lay up technique) and tested. Computer algorithm using C-language has been used for the design of constant cross-section leaf spring. The results showed that a spring width decreases hyperbolically and thickness increases linearly from the spring eyes towards the axle seat. The finite element results using ANSYS software showing stresses and deflections were verified with analytical and experimental results. The design constraints were stresses (Tsai-Wu failure criterion) and displacement. Compared to the steel spring, the composite spring has stresses that are much lower, the natural frequency is higher and the spring weight is nearly 85 % lower with bonded end joint and with complete eye unit.

Keywords: leaf spring; composite; C-language; bonded joints; failure criterion.

1. INTRODUCTION

In order to conserve natural resources and economize energy, weight reduction has been the main focus of automobile manufacturer in the present scenario. Weight reduction can be achieved primarily by the introduction of better material, design optimization and better manufacturing processes.

The suspension leaf spring is one of the potential items for weight reduction in automobile as it accounts for ten to twenty percent of the unsprung weight. This helps in achieving the vehicle with improved riding qualities. It is well known that springs, are designed to absorb and store energy and then release it. Hence, the strain energy of the material becomes a major factor in designing the springs. The relationship of the specific strain energy can be expressed as

$$U = \frac{\sigma^2}{\rho E}, \quad (1)$$

where σ is the strength, ρ the density and E the Young's modulus of the spring material. It can be easily observed that material having lower modulus and density will have a greater specific strain energy capacity. The introduction of composite materials was made it possible to reduce the weight of the leaf spring with out any reduction on load carrying capacity and stiffness. Since; the composite materials have more elastic strain energy storage capacity (1) and high strength-to-weight ratio as compared to those of steel.

Several papers were devoted to the application of composite materials for automobiles I. Rajendran [1, 2] studied the application of composite structures for automobiles and design optimization of a composite leaf spring. Great effort has been made by the automotive

industries in the application of leaf springs made from composite materials [3, 4]. S. Vijayarangan [5] showed the introduction of fiber reinforced plastics (FRP) made it possible to reduce the weight of a machine element with out any reduction of the load carrying capacity. Because of FRP materials high elastic strain energy storage capacity and high strength-to-weight ratio compared with those of steel, multi-leaf steel springs are being replaced by mono-leaf FRP springs [6, 7]. In every automobile, i.e. four wheelers and railways, the leaf spring is one of the main components and it provides a good suspension and it plays a vital role in automobile application. It carries lateral loads, brake torque, driving torque in addition to shock absorbing. The advantage of leaf spring over helical spring is that the ends of the spring may be guided along a definite path as it deflects to act as a structural member in addition to energy absorbing device. The geometry of the Steel leaf spring is shown in Fig. 1.

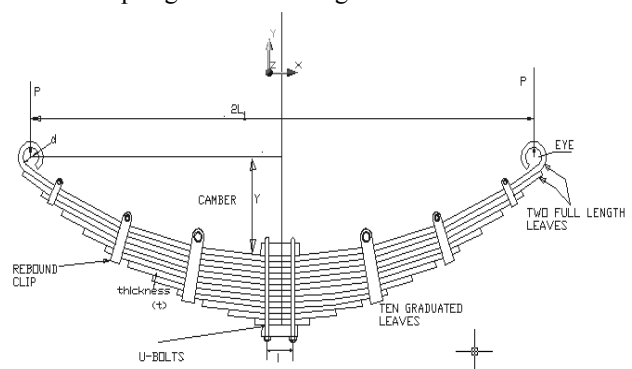

Fig. 1. Leaf spring

2. SPECIFICATION OF THE PROBLEM

The objective of the present work is to design, analyse, fabricate and testing of unidirectional Glass Fiber/Epoxy

*Corresponding author. Tel.: +91-0422-2572177; fax: +91-422-2573833. E-mail address: gsshivashankar@yahoo.co.in (G. S. Shiva Shankar)

complete mono composite leaf spring with out end joints and composite leaf spring using bonded end joints using hand-lay up technique. This is an alternative, efficient and economical method over wet filament-winding technique [1]

3. DESIGN PARAMETER OF STEEL LEAF SPRING

Parameters of the steel leaf spring used in this work are shown in Table 1.

Table 1. Parameters of steel leaf spring [2]

Parameter	Value
Material selected – Steel	55Si2Mn90
Tensile strength (N/mm ²)	1962
Yield strength (N/mm ²)	1470
Young's modulus E (N/mm ²)	$2.1 \cdot 10^5$
Design stress (σ_b) (N/mm ²)	653
Total length (mm)	1190
The arc length between the axle seat and the front eye (mm)	595
Arc height at axle seat (mm)	120
Spring rate (N/mm)	32
Normal static loading (N)	3850
Available space for spring width (mm)	60 – 70
Spring weight (kg)	26

4. DESIGNS AND FABRICATION OF COMPOSITE MONO LEAF SPRING

Considering several types of vehicles that have leaf springs and different loading on them, various kinds of composite leaf spring have been developed. In multi-leaf composite leaf spring, the interleaf spring friction plays a spoil spot in damage tolerance. It has to be studied carefully.

The following cross-sections of mono-leaf composite leaf spring for manufacturing easiness are considered.

1. Constant thickness, constant width design.
2. Constant thickness, varying width design.
3. Varying width, varying thickness design.

In this paper, only a mono-leaf composite leaf spring with varying width and varying thickness is designed and manufactured. Computer algorithm using C-language has been used for the design of constant cross-section leaf spring. The results showed that a spring width decreases hyperbolically and thickness increases linearly from the spring eyes towards the axle seat. Fig. 2 shows flowchart of computer algorithm for design of composite leaf spring. The parameters of composite leaf spring are shown in Table 2. The material properties of E-Glass/Epoxy [2] are listed in Table 3.

Table 2. Parameters at center and end points for composite leaf spring

Parameters	At center	At end
Breadth in mm	45	69
Thickness in mm	150	21

Table 3. Material properties of E-Glass/Epoxy

SI No	Properties	Value
1.	Tensile modulus along X-direction (E_x), MPa	34000
2.	Tensile modulus along Y-direction (E_y), MPa	6530
3.	Tensile modulus along Z-direction (E_z), MPa	6530
4.	Tensile strength of the material, MPa	900
5.	Compressive strength of the material, MPa	450
6.	Shear modulus along XY-direction (G_{xy}), MPa	2433
7.	Shear modulus along YZ-direction (G_{yz}), MPa	1698
8.	Shear modulus along ZX-direction (G_{zx}), MPa	2433
9.	Poisson ratio along XY-direction (ν_{xy})	0.217
10.	Poisson ratio along YZ-direction (ν_{yz})	0.366
11.	Poisson ratio along ZX-direction (ν_{zx})	0.217
12.	Mass density of the material (ρ), kg/mm ³	$2.6 \cdot 10^{-6}$
13.	Flexural modulus of the material, MPa	40000
14.	Flexural strength of the material, MPa	1200

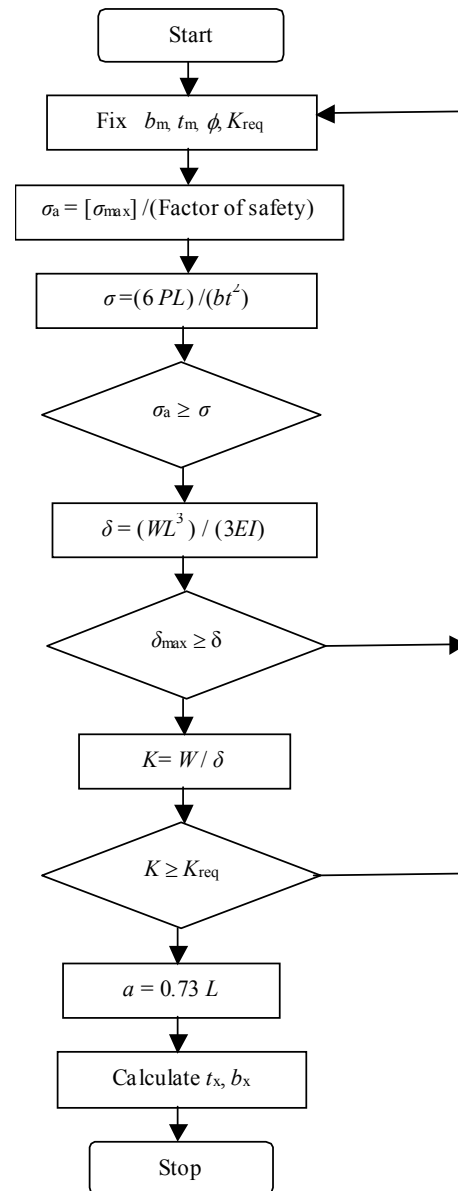

Fig. 2. Flowchart of computer algorithm for design of composite leaf spring (notations are provided in the chapter NOTATIONS)

4.1. Lay up Selection

The amount of elastic energy that can be stored by a leaf spring varies directly with the square of maximum allowable stress and inversely with the modulus of elasticity both in the longitudinal direction. Composite materials like the E-Glass/Epoxy in the direction of fibers have good characteristics for storing strain energy. So, the lay up is selected to be unidirectional along the longitudinal direction of the spring. The unidirectional lay up may weaken the spring at the mechanical joint area and require strengthening the spring in this region.

4.2. Fabrication Process

The constant cross section design is selected due to its capability for mass production, and to accommodate continuous reinforcement of fibers and also it is quite suitable for hand lay-up technique.

Many techniques can be suggested for the fabrication of composite leaf spring from unidirectional GFRP. Composite leaf spring was fabricated using wet filament-winding technique [1]. In the present work, the hand lay-up process was employed.

The templates (mould die) were made from wood and plywood according to the desired profile obtained from the computer algorithm. The glass fibers were cut to the desired lengths, so that they can be deposited on the template layer by layer during fabrication. In the conventional hand lay-up technique, a releasing agent (gel/wax) was applied uniformly to the mould which had good surface finish. This is followed by the uniform application of epoxy resin over glass fiber. Another layer is layered and epoxy resin is applied and a roller was used to remove all the trapped air. This process continued till the required dimensions were obtained. Care must be taken during the individual lay-up of the layers to eliminate the fiber distortion, which could result in lowering the strength and rigidity of the spring as a whole. The duration of the process may take up to 30 min. The mould is allowed to cure about 4 – 5 days at room temperature. Mono composite leaf springs with and without eye ends was fabricated by using above said technique.



Fig. 3. Complete composite mono leaf spring

The selected glass fiber is woven roving 360 GSM and epoxy resin is 520F with hardener 758. The fibers are cut into the required length of the leaf spring and are layered to get the final shape of the leaf spring. For every 100 parts by weight of epoxy resin, 10 – 12 parts by weight of

hardener 758 is mixed well at a temperature of 20 – 40 °C. The fabricated composite leaf spring is shown in Fig. 3.

4.3. Testing of Steel and Composite Mono Leaf Spring

The steel and composite leaf springs are tested by using leaf spring test rig. The experimental set up is shown in Figs. 4 (a), (b) and (c). The leaf springs are tested following standard procedures recommended by SAE. The spring to be tested is examined for any defects like cracks, surface abnormalities, etc. The spring is loaded from zero to the prescribed maximum deflection and back to zero. The load is applied at the centre of spring; the vertical deflection of the spring centre is recorded in the load interval of 50 N.



Fig. 4 (a). Static test of composite mono leaf spring

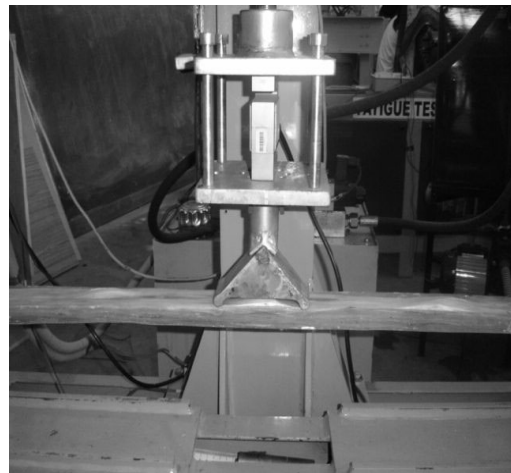

Fig. 4 (b). Static load test for maximum deflection



Fig. 4 (c). Static load test for steel leaf spring

5. THREE-DIMENSIONAL FINITE ELEMENT ANALYSIS

To design composite leaf spring, a stress analysis was performed using the finite element method done using ANSYS software. Modeling was done for every leaf with eight-node 3D brick element (solid 45) and five-node 3D contact element (contact 49) used to represent contact and sliding between adjacent surfaces of leaves. Also, analysis carried out for composite leaf spring with bonded end joints for Glass/Epoxy, Graphite/Epoxy and Carbon/Epoxy composite materials and the results were compared with steel leaf spring with eye end. The maximum peel and shear stresses along the adhesive layer were measured. Figs. 5 to 14 represent FEA results for steel and mono composite leaf spring (Glass/Epoxy). The maximum peel and shear stresses along the bonded adhesive layer for glass/epoxy were measured and plotted as shown in Figs. 15 and 16.

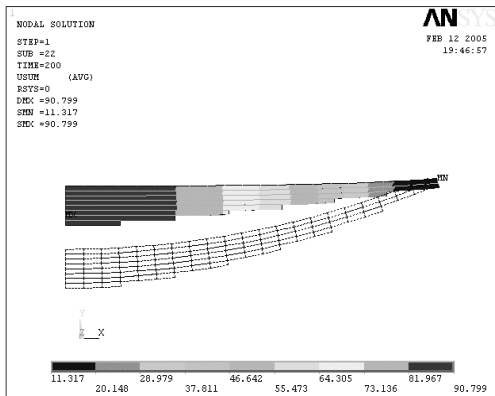

Fig. 5. Displacement pattern for steel leaf spring

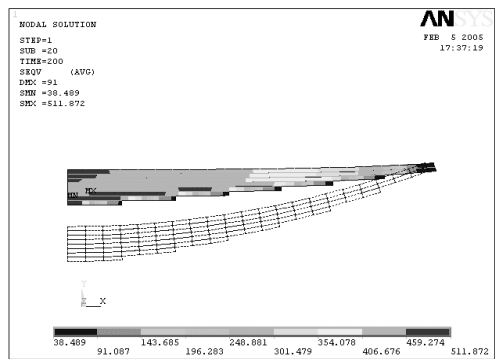

Fig. 6. Stress distribution for steel leaf spring

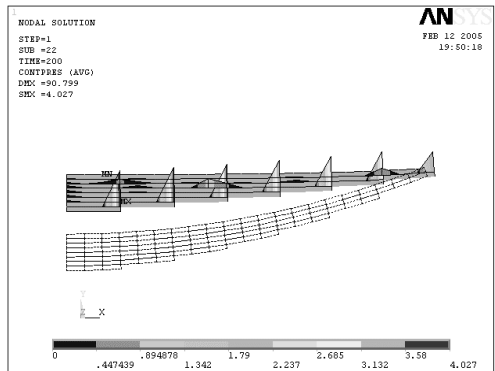

Fig. 7. Contact pressure distribution for steel leaf spring

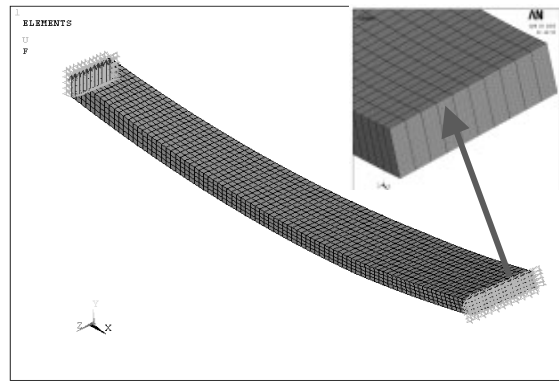

Fig. 8. Boundary conditions and meshed model of mono composite leaf spring

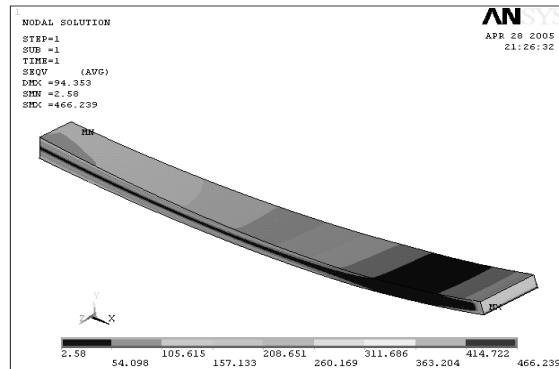

Fig. 9. Stress distribution for Glass/Epoxy composite mono leaf spring

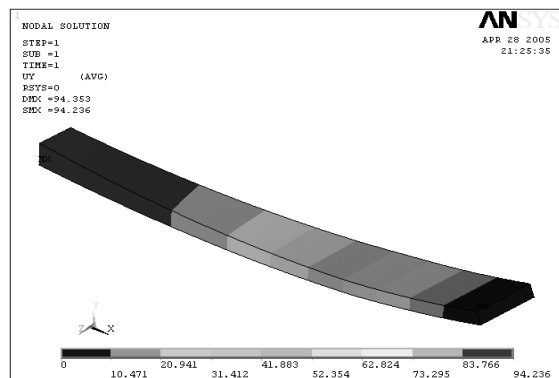

Fig. 10. Displacement pattern for Glass/Epoxy composite leaf spring

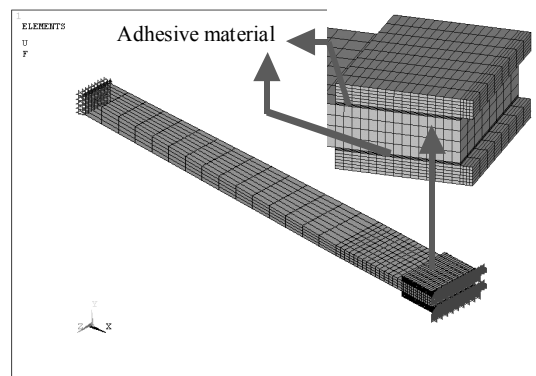

Fig. 11. Boundary conditions for bonded joints in composite leaf spring

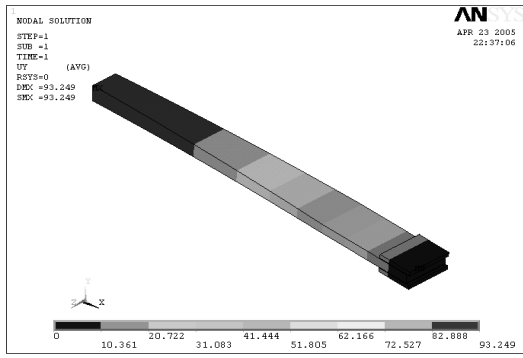

Fig. 12. Displacement pattern for Glass/Epoxy composite leaf spring with bonded end joint

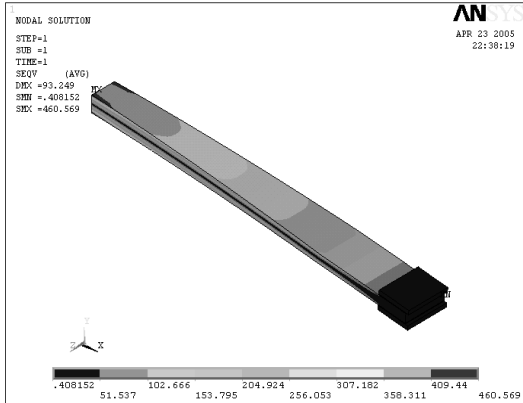

Fig. 13. Stress distribution for Glass/Epoxy composite leaf spring with bonded end joint

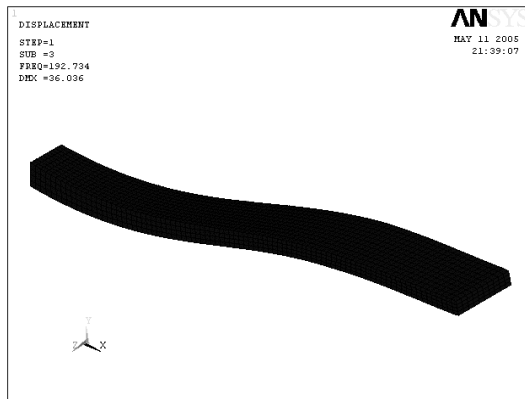

Fig. 14. Mode shapes of composite leaf spring

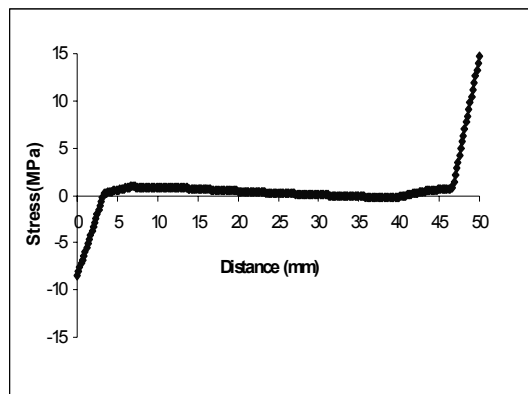

Fig. 15. Peeling stress distribution in adhesive layer for Glass/Epoxy leaf spring

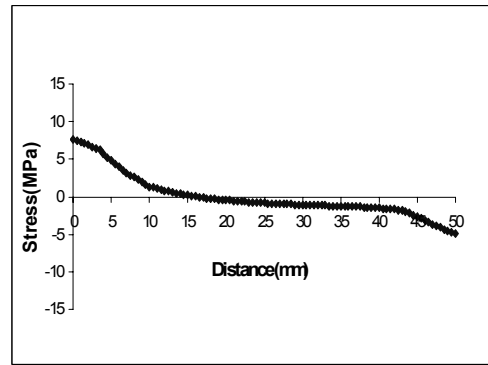

Fig. 16. Shear stress distribution in adhesive for Glass/Epoxy leaf spring

6. RESULTS AND DISCUSSION

Experimental results from testing the leaf springs under static loading containing the stresses and deflection are listed in the Table 4. These results are also compared with FEA in Table 4. Testing has been done for unidirectional E-Glass/Epoxy mono composite leaf spring only. Since the composite leaf spring is able to withstand the static load, it is concluded that there is no objection from strength point of view also, in the process of replacing the conventional leaf spring by composite leaf spring. Since, the composite spring is designed for same stiffness as that of steel leaf spring, both the springs are considered to be almost equal in vehicle stability. The major disadvantages of composite leaf spring are chipping resistance. The matrix material is likely to chip off when it is subjected to a poor road environments (that is, if some stone hit the composite leaf spring then it may produce chipping) which may break some fibres in the lower portion of the spring. This may result in a loss of capability to share flexural stiffness. But this depends on the condition of the road. In normal road condition, this type of problem will not be there. Composite leaf springs made of polymer matrix composites have high strength retention on ageing at severe environments.

The steel leaf spring was replaced with an composite one. The objective was to obtain a spring with minimum weight which is capable of carrying given static external forces by constraints limiting stresses (Tsai-Wu criterion) and displacements. The weight of the leaf spring is reduced considerably about 85 % by replacing steel leaf spring with composite leaf spring. Thus, the objective of the unsprung mass is achieved to a larger extent. The stresses in the composite leaf spring are much lower than that of the steel spring.

Table 5. Comparison of deflections and bending stresses in E-Glass/Epoxy complete mono leaf spring and spring with bonded joints

		FEA	Experimental
Maximum deflection(mm)	Integral eye	94	101
	Bonded joint	93	104
Maximum bending stress (MPa)	Integral eye	460	500
	Bonded joint	466	520

Table 5 describes the comparison of deflections and bending stresses in E-Glass/Epoxy complete mono leaf

Table 4. Comparison results of load, deflection and stresses*

Material	Static load (N)	Maximum deflection (mm)		Maximum stress (MPa)		Weight (kg)
		FEA	Experimental	FEA	Experimental	
Steel	3980	90	107.5	511	503.3	26.0
E-Glass/Epoxy	4250	94	105.0	466	473.0	3.88
Graphite/Epoxy	–	68	–	422	–	2.33
Carbon/Epoxy	–	62	–	413	–	2.39

*In Table 4 Graphite/Epoxy and Carbon/Epoxy were not considered for fabrication as well as testing of leaf spring due to higher cost of the materials.

Table 6. Natural frequencies of composite leaf spring

Modes	1	2	3	4	5
Frequencies (Hz)	33	135	192	288.5	368.7

spring and spring with bonded joints. Adhesively bonded end joints enhance the performance of composite leaf spring in comparison with bolted joints since, delamination, matrix cracking and stress concentration at the holes are observed in bolted joints. Scarf type of bonded joints enhances the strength considerably without peel separation compared to the lap type of bonded joints. Induced peel and shear stresses are much below the yield limits. FEA results have provided the necessary link between mechanical properties, component design and fabrication to achieve performance optimization. Composite mono leaf spring with integral eye is economical and showed better performance.

Harmonic analysis has been done on composite leaf spring to find the modal frequency. The first five natural frequencies are listed in the Table 6. The natural frequency of composite leaf spring is higher than that of the steel leaf spring and is far enough from the road frequency to avoid the resonance.

CONCLUDING REMARKS

- The development of a composite mono leaf spring having constant cross sectional area, where the stress level at any station in the leaf spring is considered constant due to the parabolic type of the thickness of the spring, has proved to be very effective;
- The study demonstrated that composites can be used for leaf springs for light weight vehicles and meet the requirements, together with substantial weight savings;
- The 3-D modeling of both steel and composite leaf spring is done and analysed using ANSYS;
- A comparative study has been made between composite and steel leaf spring with respect to weight, cost and strength;
- The analytical results were compared with FEA and the results show good agreement with test results;
- From the results, it is observed that the composite leaf spring is lighter and more economical than the conventional steel spring with similar design specifications;
- Adhesively bonded end joints enhance the performance of composite leaf spring for delamination and stress concentration at the end in compare with bolted joints;

- Composite mono leaf spring reduces the weight by 85 % for E-Glass/Epoxy, 91 % for Graphite/Epoxy, and 90 % for Carbon/Epoxy over conventional leaf spring.

NOTATIONS

b_m – width at middle (mm); t_m – thickness at middle (mm); ϕ – taper ratio; K_{req} – stiffness of the spring; σ_a – design bending stress, (N/mm²); δ – deflection of the spring, (mm); δ_{max} – camber of the spring, (mm); a – distance from the centre to which the width varies with thickness; L – distance between the centres to one end of the eye, (mm).

Acknowledgements

The author would like to thank Department of Science and Technology (DST) for financing this project. Also thanks are extended to PSG College of Technology, Coimbatore, INDIA for support throughout the execution of the experimental work.

REFERENCES

1. **Rajendran, I., Vijayarangan, S.** Optimal Design of a Composite Leaf Spring using Genetic Algorithms *Int. Jr. of Computer and Structures* 79 2001: pp. 1121 – 1129.
2. **Rajendran, I., Vijayarangan, S.** Design and Analysis of a Composite Leaf Spring *Journal of Institute of Engineers India* 82 2002: pp. 180 – 187.
3. **Daugherty, R. L.** Composite Leaf Springs in Heavy Truck Applications. K. Kawata, T. Akasaka (Eds). *Composite Materials Proceedings of Japan-US Conference* Tokyo, 1981: pp. 529 – 538.
4. **Dharam, C. K.** Composite Materials Design and Processes for Automotive Applications. The ASME Winter Annual Meeting, San Francisco, December 10-15, 1978: pp. 19 – 30.
5. **Vijayarangan, S., Ganesan, N.** Static Stress Analysis of a Composite Bevel Gear using a Three-dimensional Finite Element Method *Computer Structures* 51 (6) 1994: pp. 771 – 783.
6. **Tanabe, K., Seino, T., Kajio, Y.** Characteristics of Carbon/Glass Fiber Reinforced Plastic Leaf Spring, *SAE* 820403 1982: pp. 1628 – 1634.
7. **Yu, W. J., Kim, H. C.** Double Tapered FRP Beam for Automobile Suspension Leaf Spring *Comp. Structure* 1998: pp. 279 – 300.
8. **Jones, R. M.** *Mechanics of Composite Materials*. 2e, Mc Graw-Hill Book Company, 1990.
9. **ANSYS Inc:** ANSYS Users Manual, Rev. 1995, 5.2-Vol. I – IV, Houston, PA.

DOI: 10.5755/j02.ms.26434