

Peculiarities of Destruction Mechanism in Ceramic Products under Simulated Exploitation Conditions

Romualdas MAČIULAITIS, Asta KIČAITĖ

Department of Building Materials, Vilnius Gediminas Technical University, Saulėtekio al. 11, LT-10223 Vilnius, Lithuania

Received 25 August 2006; accepted 07 November 2006

The article analyses the processes which take place in ceramic samples during their freezing and thawing. The deformation parameters change is connected with the structure of ceramic samples and the processes of filling the porous volume with water. Before unilateral cyclic freezing and thawing the porous volume of ceramic products must be partly filled for allowing the migration processes to take place. The destruction of ceramic products is a complicated process and it consists of three stages.

Keywords: dilatometric device, linear deformation, cyclical freezing and thawing, open porous volume.

1. INTRODUCTION

Some destruction processes can be seen in buildings of structural ceramics products after some service period. These processes are determined by moisture and temperature fluctuations. The latter processes, in their turn, are determined by water freezing and distribution, taking place both before freezing and during it [1, 2].

It is well-known that during freezing of the soaked building ceramics products, the water in them turns into ice. In this case stresses and strains are induced when volume increases by 9%. The possibility to resist such stresses and strains depends on the structure and phase composition of the material carcass [1–3].

The stresses developed in ceramic products under uniform saturation conditions and freezing depend, in general, on the distribution of pores and capillaries with regard to their size and geometry [4–7]. These parameters predetermine the degree of water saturation, the quantity of freezing water and (connected with it) the development of stresses and strains [1, 2, 8, 9]. The probability to develop dangerous stresses and strains is smaller in samples with a better structure, i.e. where reserve pores predominate serving as the volume for excess water quantity.

Before developing the first indications of destruction, considerable changes take place in the inner structure of a ceramic product. The linear deformation of a ceramic body taking place under repeated unilateral freezing and thawing results in accumulations of material fatigue and residual strains. The increasing residual deformations characterise the degree of destruction of a ceramic product [1, 2, 10].

This question became of interest long time ago. First of all, the linear deformations of ceramic products under freezing conditions were investigated. The researchers applied the quartz dilatometer designed for a volumetric freezing for a rapid evaluation of ceramic tile by comparing the qualitatively burned tile with poorly produced ones [11]. The resistance to freezing investigations were performed by volumetric means. In this case the processes taking place in a ceramic product do not reflect processes

when freezing proceeds under natural service conditions [1, 2]. The investigators for a long time shared one mind that the dilatometric method is suitable for investigating ceramic products [11]. And now this method is widely applied to analyse the processes in ceramic products [1–3, 8, 12–14].

By applying the unilateral freezing dilatometry it is possible to evaluate the changes of the inner structure of products, which are connected with stresses and deformations resulted by freezing them and thawing from one side [1, 2, 8, 10].

The aim of this work is to apply the dilatometer of unilateral freezing for a detailed investigation of ceramic product porous volume filling with water and to give an additional information concerning the processes in ceramic products. The same to investigate the peculiarities of water migration, the dynamics of redistribution of filling with water as well as the destruction processes taking place in ceramic products.

2. INVESTIGATION METHODS AND EQUIPMENT

Ceramic bricks have been investigated; they were made by plastic shaping and burnt in the manufacturing conditions. The effective porosity W_E of these bricks was from 12.24% to 31.65%.

The effective porosity was calculated in following way:

$$W_E = \rho \frac{m_1 - m_0}{m_0} \cdot 100\% , \quad (1)$$

where ρ is the density of ceramic specimen, m_1 is the mass of specimen after 3 days saturation, m_0 is the dry mass of specimen.

The reserve of pore volume was calculated in following way:

$$R = \left(1 - \frac{W_E}{W_R} \right) \cdot 100\% , \quad (2)$$

where W_E is the effective porosity, W_R is the total open porosity.

*Corresponding author. Tel.: +370-5-2745219; fax.: +370-5-2745016.
E-mail address: asta.kecaite@st.vtu.lt (A. Kičaitė)

The ceramic bricks were cut in two specimens.

Before defining the water absorption, the samples were dried up to a stable mass. Then they were immersed in water and kept there for 3, 4, 58, 62 days.

The investigations of deformations were performed by a special dilatometric device of unilateral freezing and thawing by a fully automated programme (Fig. 1). The sequence of the experiment is as following: the preliminary soaked half brick is fixed from sides by six threaded bolts with the half brick side upwards in the building façade. In the centre of sample upper plane, the gauge of strain measuring is fixed and on the plane surface a micro-refrigerator is lowered [1, 2, 8].

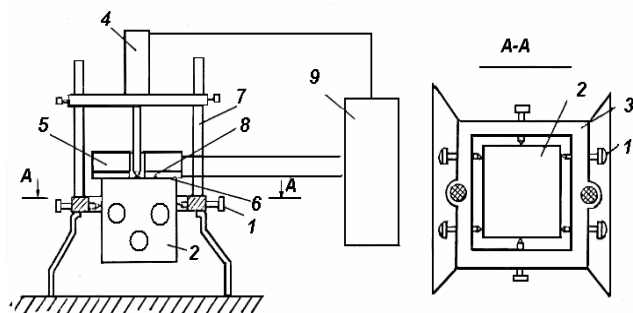

Fig. 1. The scheme of unilateral freezing/heating dilatometer unit:

1 – bolts; 2 – test specimen with thermal insulation round; 3 – base; 4 – deformation sensor, 5 – freezer unit; 6 – temperature sensor; 7- guides; 8 – freezing surface of specimen; 9 – deformation measuring unit

During 7 hours, 3 cycles of freezing and thawing were performed. In the programme selected, different durations of the 1st, 2nd and 3rd freezing periods were planned. The first freezing cycle was longer – 1.5 h, for getting the required sample freezing. Further, taking into account the fact that a partial thawing was performed, the freezing period was shortened up to 1 h. In this way a partial thawing of the sample was imitated, and it is characteristic of a natural influence.

The thickness of the investigated layer was 15 mm and it coincides with the brick surface without reaching the technological cavities. Namely, in this layer the destruction of brick surfaces of building façades [1, 2, 6, 8] prevails.

The absolute values of deformation parameters have been calculated: Δh_1 – the largest common linear deformation in the 1st freezing cycle, μm ; Δh_2 – the largest common linear deformation in the 2nd freezing cycle, μm ; Δh_3 – the largest common linear deformation in the 3rd freezing cycle, μm .

Also, the investigation has been performed by a dilatometer, which can be applied for measuring deformation changes in three spots of freezing surface.

X-ray phase analysis was conducted using a DRON-2, (Cu anticathode, Ni filter, anode voltage 30 kV). The phase composition of ceramics products was identified using standard ASTM file data.

Microscopic structure analysis of ceramics products was conducted using an optical microscope Motic.

3. RESULTS AND DISCUSSION

3.1. Peculiarities of filling ceramic products with water

Detailed investigations have been performed by the dilatometer device.

A close interconnection between the saturation and the degree at deformations growth has been found (Table 1). The change of porous volume filling with water and deformation properties depends on the degree of saturation with water. Under the same saturation degree, the parameters of deformation depend on the structure of the ceramic products.

For investigations the half bricks have been selected, the porous volume of which is filled with water in a different way. The porous volume of 3 and 10 bricks was filled rather actively and rapidly, whereas filling the 14 and 18 was slower.

Filling of porous volume gradually increases. In this case, after a cyclic freezing and thawing of ceramic samples, higher values of deformation parameters are found. This can be seen in the data of Table 1. In ceramic items 3 and 10, positive and larger values of deformation parameters can be observed. In case of sample 10, we observe that, after 4 days of immersion, the value of common linear deformation value in the third cycle Δh_3 was 4.6 μm and after 61 days of immersion the value of common linear deformation value in the third cycle Δh_3 has reached 23.4 μm .

Table 1. Change of deformation parameters depending on keeping in water time

Sample number and keeping in water period	Common linear deformation (μm)		
	Δh_1	Δh_2	Δh_3
3 (4 days)	1.9	5.2	5.7
3 (61 days)	9	11.7	12.8
10 (4 days)	2.5	3.5	4.6
10 (61 days)	20.8	21.8	23.4
14 (4 days)	-1.25	-1.25	-1.0
14 (58 days)	1.3	1.4	1.5
18 (4 days)	-2.6	-2.6	-2.7
18 (58 days)	2.8	3.0	3.0

It is possible to state that in this case water migration and accumulation prevail on the account of ice crystals growth in the defective zones of surface.

Meanwhile, for other (14 and 18) specimens such an intensive development of stresses and strains is not a characteristic one, because the water which filled insufficiently pores and capillaries during the cyclic influence is quickly removed from the dangerous surface zone.

However, during soaking such items for a long time, the defective zones are filled by water slowly. In this case the deformation parameters change their values from the negative to small positive ones. No doubt, such products will endure much more unilateral freezing and thawing cycles.

Because the destructive effect of water manifests itself in filling pores, capillaries and defective spaces during migration processes and by some pressure during freezing, it is not rational to try to fill fully with water the porous volume of specimens, because the real effect would be distorted.

Therefore it is advisable to soak ceramic samples with water only 4 days before flue direct freezing and thawing.

In order to find out whether the stresses and strains develop uniformly in the whole surface of a freezing ceramic item, two deformation sensors were placed at the freezing surface sides and one deformation sensor in the centre. In this case the growth of deformations was observed in all three spots of surface of the ceramic items.

The development of deformations in different places of a ceramic sample was not uniform. Table 2 shows that in a sample larger values of deformations were found in the right side of the sample (ceramic half brick 2), in the other case in the sample centre (ceramic half brick 1).

The probability of the first destruction phenomenon is the highest in places where also the highest deformation parameters are fixed. The first signs of destruction may appear not only at the borders of samples, but also in the middle, depending on the place where inner defective zones are present. The investigations have shown that in this case destruction started in places where maximum deformation values were found.

Table 2. Change of common linear deformations depending on deformation sensors place

No. of sample and place of the deformation sensor	Common linear deformation (μm)		
	Δh_1	Δh_2	Δh_3
1 (in the middle of the sample)	18	20	20.5
1 (on the left side of the sample)	1.5	1.5	1.5
1 (on the right side of the sample)	5	5	5
2 (on the left side of the sample)	1	2	2.1
2 (in the middle of the sample)	0.5	0.7	0.75
2 (on the right side of the sample)	2	2.4	2.7

Such a unhomogeneous development of the first disintegration indicators is connected with non-uniform structure of the ceramic products.

3.2. Peculiarities of destruction of ceramic products

For detailed investigations a sample was selected which X-ray diffraction pattern are present in Fig. 2. Anorthite, diopside and quartz dominated in this burned ceramics sample. The formation of anorthite and diopside showed that ceramic sample was burned in reductive conditions.

Ceramic sample has been saturated during 4 days. The porous volume reserve parameter R value of the selected

for investigations product was equal to 16.7 %. During a day from 2 up to 3 freezing and cooling cycles were applied and then the specimen was dipped in water.

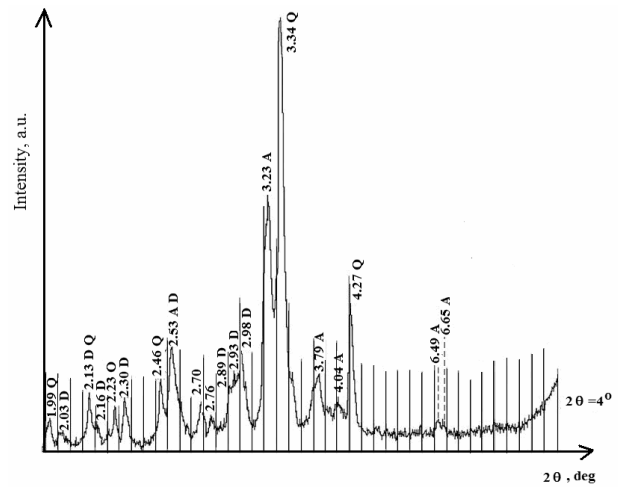

Fig. 2. X-ray diffraction pattern of the ceramics sample (A – anorthite; D – diopside; Q – quartz)

Ceramic articles are usually attributed to consolidated porous materials. Depending on the manufacturing way and conditions, they may be considered as strongly and weakly consolidated systems. In this case, the ceramic article may be attributed to strongly consolidated systems and one can divide its disintegration process into 3 stages.

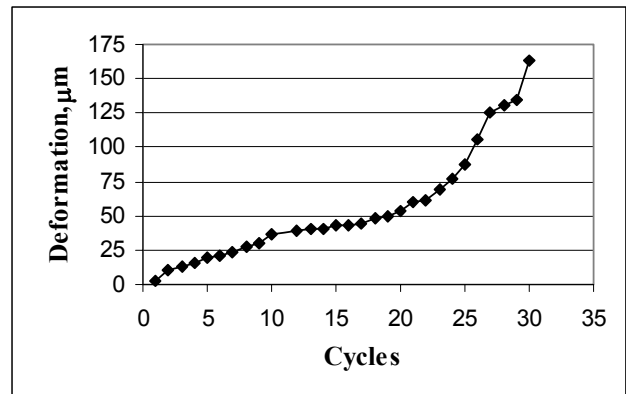

Fig. 3. Growth of common deformations with number of cycles

Fig. 3 presents the general growth of deformations from the first cycle up to the last one.

Fig. 4 presents the growth of initial common deformations with 1st cycle.

First of all, water fills the defective zones and open pores as well as capillaries. The started inconspicuous growth of deformations is connected with the process of gradual filling of the reserve of porous volume by water.

Further, by unilateral freezing and especially by partial thawing the more distant from the surface defective zones start to be filled with water. It is also seen by the less growth of the curve presented in Fig. 3.

Ice crystals in the defective zones grow gradually, especially when non-full thawing predominates. Structural defects are continued to fill with water. Already in this stage one can believe in weakening internal bonds between the ceramic material particles.

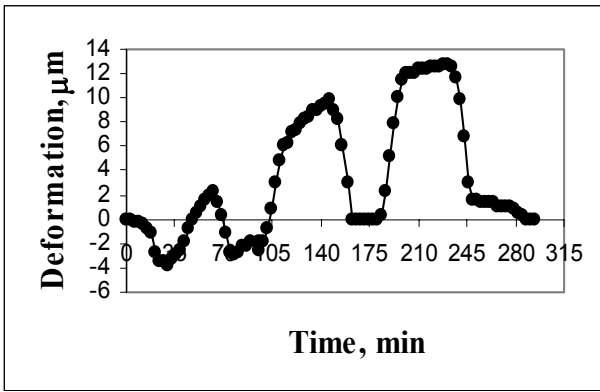

Fig. 4. Growth of deformations in the 1st, 2^d and 3rd cycles

In the second stage the first ruptures of internal bonds appear and lead to the internal defective zones amalgamation. The destruction starts to be visually observed. Also, at this time the growth of common deformation parameters increases considerably.

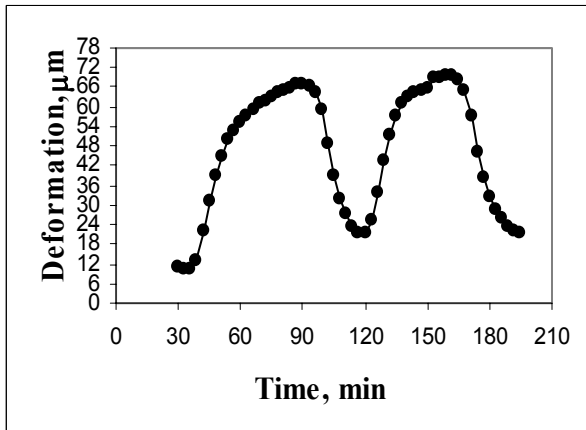

Fig. 5. Growth of deformations in cycles 22 and 23

At the same time the absolute reserve of porous volume decreases. It is possible to believe that the common ice volume in pores and capillaries gradually increases when water migrates from small pores as well as from capillaries and at the same time the values of common deformational parameters grow.

In the cycle 23, when observing the deformation growth, we see an additional rise of deformational curve. It may be explained by the fact that in the ceramic product an additional ice crystallization takes place in defective and mostly dangerous product spots.

Also, with this cycle a more pronounced growth of deformational parameters values begins in Fig. 5. It is also connected with a gradual accumulation of water and ice in the pores and capillaries, as well as in defective spots. In this stage the bonds between the ceramic material particles start to break.

In the 3rd stage, the bonds break completely at the weakest points. The process of surface disintegration can be observed; it may be expressed by cracking, crumbling away, ripping off. In this case macro-destruction may be observed.

In this, third, stage further water migration in the disintegrating ceramic material defective spaces and further crystallization of ice crystals. The final visual

destruction of a ceramic material starts when proceeding to thawing takes place during an ice crystallization and temperatures stresses are removed.

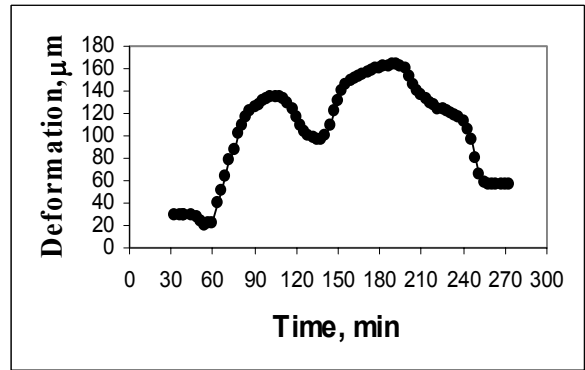

Fig. 6. Deformation growth in cycles 29 – 30

After 32 cycles of freezing and thawing the sample has been examined and cracks have been replaced. The final visual destruction of a ceramic material presents in the Fig. 7 and Fig. 8.

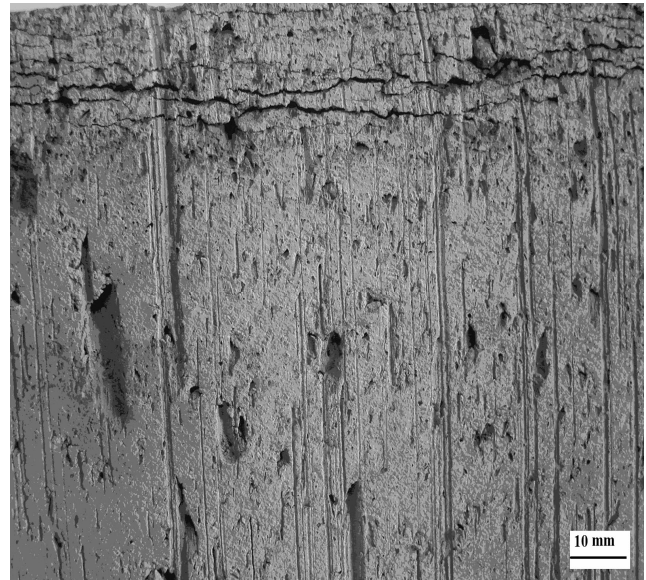

Fig. 7. The visual destruction of a ceramic material

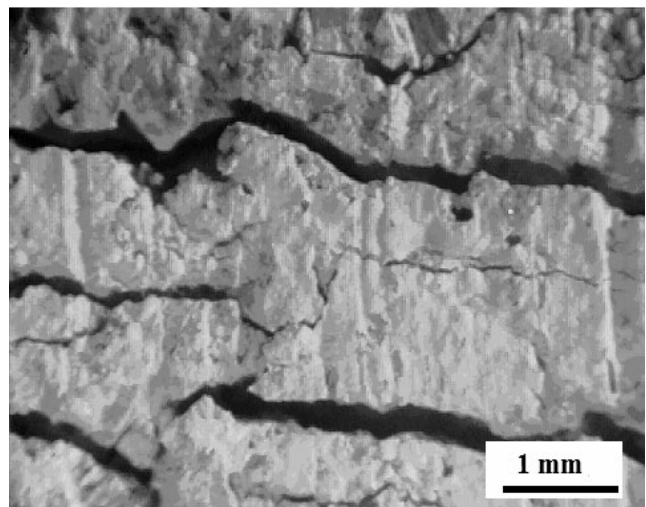

Fig. 8. The view of destruction of a ceramic sample by using optical microscope (×12)

More detailed destruction is presented in Fig. 8.

Thus destruction process of a ceramic sample which was immersed in water and cyclically frozen is gradual. Such a process consists of three stages.

First, the water migration takes part in defective zones. In this case the process of filling pores and capillaries with water is of great importance. When water turns into ice, in the ceramic product stresses and the resulting deformations develop.

A linear distortion of a ceramic article under a multi-time unilateral cooling and thawing results in a fatigue and accumulation of residual deformations. The developing residual deformations characterize the destruction degree of a ceramic product microstructure. In the second stage the first destruction phenomena develop.

In the third stage a visual destruction of a ceramic product develops; it may include deeper layers of a ceramic product.

CONCLUSIONS

1. In order to model in detail processes taking place in ceramic products under natural conditions, it is necessary to saturate partly the products by water for allowing the migration processes to come out.
2. Filling the porous volume of ceramic products with water depends on the water saturation period. Though the larger the porous volume filling with water, the higher the deformation parameters.
3. The first evidences of ceramic product destruction may appear in different weakest freezing spots where the highest values of common linear deformations have been observed.
4. The destruction process of ceramic articles consists of 3 stages: 1) filling with water defective spots and pores, alongside with capillaries (and during it minimal stresses and deformations connected with them appear); 2) breaking the bonds between the ceramic material particles, developing the internal destruction; 3) becoming visual the micro-destruction of a ceramic product (and they result in releasing the ceramic body of temperature stresses of additional ice crystallization process, when passing to thawing).

REFERENCES

1. **Mačiulaitis, R.** Frost Resistance and Durability of Ceramic Façade. Vilnius, Technika, 1997 (in Russian).

2. **Sadūnas, A.** Durability of Aluminium Silicate Products. Vilnius, VPU, 1997. (in Lithuanian).
3. **Franke, L., Bentrup, H.** Evaluation of the Frost Resistance of Bricks in Regard to Long Service Life. Part 2. *Ziegelindustrie International* 9 1993: pp. 528 – 536.
4. **Šveda, M.** Frost Resistance of Brick. *American Ceramic Society Bulletin* 9 2001: pp. 46 – 48.
5. **Ikeda, H, Kim, H-S., Kaizu, K., Higashi, A.** Influence of Firing Temperature on Frost Resistance of Roofing Tiles. *Journal of the European Ceramic Society* 14 2004: pp. 3671 – 3677.
6. **Nakamura, M.** Indirect Evolution of Frost Susceptibility of Building Materials. *Am. Ceram. Soc. Bull.* 12 1988: pp. 1964 – 1965.
7. **Nakamura, M., Togaya, Okuda, S.** Effects of Dimensional Distribution of Pores in Porous Ceramic on Frost Resistance under One Dimensional Cooling. *J. Ceram. Soc. Japan* 85 1977: pp. 549 – 553.
8. **Sadunas, A., Bure, D.** Water Migration Processes in Heavy Clay Ceramics under Freezing-Thawing Cycles. *Industrial Ceramics* 3 2000: pp. 153 – 159.
9. **Sadunas, A., Matšulaitis, R., Bure, D.** Exploitation Frost Resistance of Ceramic Façade Products. *9. Internationale Baustoff und Silikattagung: Tagungsbericht. Sektion 3.* Weimar, 1973: pp. 41 – 47 (in Russian).
10. **Kičaitė, A., Mačiulaitis, R.** New Equations for Predicting the Frost Resistance of Ceramic Products by Deformational Parameters. *Civil Engineering (Statyba)* VII (2) 2001: pp. 131 – 137 (in Lithuanian).
11. **Parashtshenko, O. D., Valeshko, K. A., Gudenko, P. M., Krasnickaja, D. N.** Rapid Method for Determination of the Frost Resistance of Ceramic Materials. *Ref. Inf. Series: The industry of wall materials and porous aggregates* ASRIEBM, 1975 (in Russian).
12. **Leman, T.** Determination of the Frost Resistance of Heavy Clay Products by Using Dilatometer. *Ziegelindustrie International* 15 1955: pp. 20 – 23 (in German).
13. **Seaverson, E. J., Brosnan, D. A.** Expansion Phenomena during Freezing of Saturated Bricks and Implications on Frost Resistance. *Ziegelindustrie International* 54 2001: pp. 12 – 19.
14. **Sadunas, A., Matšulaitis, R., Kitshaite, A., Bure, D.** Complex Approach to the Assessment of Frost Resistance of Heavy Clay Ceramics. *Interbrick* 3 1989: pp. 16 – 20.

DOI: 10.5755/j02.ms.26472