

Simulation of a Shrinkage Cavity in the Risers of Ductile Iron Castings

Stasys BOČKUS, Arvydas VENCKŪNAS, Gintautas ŽALDARYS*

Department of Metal Technology, Kaunas University of Technology, Kęstučio 27, LT-44025 Kaunas, Lithuania

Received 30 September 2004; accepted 07 October 2004

A lot of methods are used for calculation of risers for castings. Calculation of risers for ductile iron castings has methods that are used for simple castings of the same cross-section. When castings have more than one element, correction ratios are used that are based only on the experimental results and even more increased. Later on, dimensions of risers are usually corrected during production, therefore, it takes a lot of time. The purpose of this work was to create a mathematical model for calculation of heat exchange in a cooling casting, which helps to calculate volume changes in a cooling casting. On the base of the mathematical model, a computer program was made. After research of technological ductile iron casting factors, the program can rather precisely, without test castings, find the best dimensions of risers for ductile iron castings. The experimental results were very similar to the results of digital simulation according to the created method.

Keywords: ductile iron, feeder, simulation, crystallization.

INTRODUCTION

Ductile iron castings, contrary to grey iron castings, have big volume shrinkage (from 2.5 % to 12 %) [1]. Volume shrinkage in ductile iron castings depends on many factors. First of all, superheating temperature of liquid metal has to be higher for ductile iron castings than for grey iron castings [2]. Higher superheating is necessary for successful spheroidizing inoculation. During inoculation, temperature decreases for 50 °C up to 100 °C, and after inoculation, metal temperature must be high enough in order to fill the mould properly.

Another factor for volume shrinkage in ductile iron castings and for the size of shrinkage cavities is pre-shrinking expansion. It sometimes reaches 0.8 % in ductile iron castings [3]. The size of this expansion depends on the chemical composition of alloy. The larger amount of carbon makes the greater nucleation of free graphite in the metallic matrix. The separation of free graphite is directly related to pre-shrinking expansion of the alloy – the larger amount of graphite nucleates, the larger expansion is. Pre-shrinking expansion starts in a casting as soon as a crust of frozen metal forms. Then a forming casting begins to expand, and if a casting mould is not hard enough, a mould cavity is blown up. When a casting begins to form, metal is still liquid inside, therefore, when the dimensions of a formed crust expand, the level of liquid metal decreases, and a shrinkage cavity increases.

In order to avoid influence of pre-shrinking expansion to the size of a shrinkage cavity, casting mould must be hard enough. When ductile iron is cast into the sand moulds, it is recommended that mould hardness would be not less than 90 units [4].

If mould hardness and chemical composition of metal can be controlled technologically, shrinkage of metal in the liquid state can be compensated only using a riser. The size of a riser has a big influence on metal consumption for a

casting. Higher metal consumption makes a casting more expensive, therefore, the dimensions of a riser must be optimal, i.e. a riser must do its function, and a shrinkage cavity must not penetrate into a casting.

The dimensions of risers can be calculated by different empirical methods [5, 6]. When temperature-dependent volume shrinkage rate of alloy is known, the general size of a shrinkage cavity is usually calculated. After that, volume of a riser is found according to its type (open or closed). These dimensions of the risers are not precise, and later on, they are corrected in the process of production. Such creation of technology takes a lot of time.

Risers can be calculated according to the heat balance of a cooling casting [7], too, i.e. a casting is divided into separate simple geometric elements, and heat change is calculated for each of them in a definite period of time when heat is transferred from metal into mould walls, as well when the heat exchanges among different elements of a casting. Different dimensions of a riser are tried, and the best dimensions of a riser are found when metal cools in it last. Some authors simulate the same heat balance with respect to material balance [8]. Such simulation is more precise because it estimates the change of metal amount in a riser, but it does not estimate the formation of a frozen metal crust.

Nowadays, the most popular software for riser simulation in the world is “MAGMASoft” [9]. It makes a virtual view of a cooling casting by the method of finite elements. When the formation of thermal centres is observed in a cooling casting, it is possible to predict not only the places of thermal stresses but also the places for risers in a casting [10, 11]. When different casting technologies and parameters are tried, it is possible to direct the crystallization of a casting towards its riser. Afterwards, by changing the dimensions of a riser, it is supervised that crystallization in a casting would happen last. The disadvantage of such a simulation is that the change of metal amount in a riser during crystallization of a casting is not estimated. Because of that, virtual

*Corresponding author. Tel.: +370-37-300420; fax.: +370-37-323461.
E-mail address: ginzald@ktu.lt (G. Žaldarys)

technology of a casting can become different from the real view.

One more disadvantage of most mathematical models, used for calculation of heat exchange, is that pouring of liquid metal into the mould is considered as instant. In fact, mould pouring lasts from ten seconds up to some tens of seconds. Therefore, metal loses part of superheat and shrinks partially, and after mould pouring, a temperature gradient between metal temperature at the top and on the bottom of the mould appears.

A MATHEMATICAL MODEL FOR CALCULATION OF HEAT EXCHANGE AND VOLUME SHRINKAGE IN A CASTING

On the base of Fourier heat conductivity equation for a rectangle parallelepiped surface (Equation 1) and for a cylindrical surface (Equation 7) under boundary conditions (2; 3; 4; 8; 9) and initial conditions (5; 6; 10; 11), a numerical calculation method of cooling metal was created. ∂T_1 , ∂ , ∂x , ∂y , ∂z were changed into finite variables ΔT_1 , Δt , Δx , Δy , Δz . Calculation was made using finite-difference process in the net method.

$$\frac{\partial T_1(x, y, z, t)}{\partial t} = a_1 \left(\frac{\partial^2 T_1}{\partial x^2} + \frac{\partial^2 T_1}{\partial y^2} + \frac{\partial^2 T_1}{\partial z^2} \right); \quad (1)$$

$$-\lambda_1 \frac{\partial T_1(l_x, t)}{\partial x} = q_{x,0}(t); \quad \frac{\partial T_1(0, t)}{\partial x} = 0; \quad q_{x,0}(t) = \frac{b_4 T_0(l_x, t)}{\sqrt{t\pi}}; \quad (2)$$

$$-\lambda_1 \frac{\partial T_1(l_y, t)}{\partial y} = q_{y,0}(t); \quad \frac{\partial T_1(0, t)}{\partial y} = 0; \quad q_{y,0}(t) = \frac{b_4 T_0(l_y, t)}{\sqrt{t\pi}}; \quad (3)$$

$$-\lambda_1 \frac{\partial T_1(l_z, t)}{\partial z} = q_{z,0}(t); \quad \frac{\partial T_1(0, t)}{\partial z} = 0;$$

$$q_{z,0}(t) = \varepsilon \sigma (T_k^4 - T_a^4); \quad (4)$$

$$T_1(x, y, z, 0) = \varphi(x, y, z); \quad (5)$$

$$T_1(x, y, z, 0) = const; \quad (6)$$

$$\frac{\partial T_1(r, z, t)}{\partial t} = \frac{a_1}{r} \left[\frac{\partial}{\partial r} \left(r \frac{\partial T_1}{\partial r} \right) + \frac{\partial}{\partial z} \left(r \frac{\partial T_1}{\partial r} \right) \right], \quad (7)$$

where: $0 < r \leq R$;

$$-\lambda_1 \frac{\partial T_1(R, t)}{\partial r} = q_{r,0}(t); \quad \frac{\partial T_1(0, t)}{\partial r} = 0; \quad q_{r,0}(t) = \frac{b_4 T_0(R, t)}{\sqrt{t\pi}}; \quad (8)$$

$$-\lambda_1 \frac{\partial T_1(H_p, t)}{\partial z} = q_{z,0}(t); \quad \frac{\partial T_1(0, t)}{\partial z} = 0;$$

$$q_{z,0}(t) = \varepsilon \sigma (T_k^4 - T_a^4); \quad (9)$$

$$T_1(r, z, 0) = \chi(r, z); \quad (10)$$

$$T_1(r, z, 0) = const, \quad (11)$$

where a_1 is a ratio of metal temperature conductivity, m^2/s ; T_1 is the initial temperature of liquid metal, K; T_0 is the initial temperature of a mould, K; x , y and z are variables of thickness, height and width, m; l_x and l_y are the half of length and width of a casting wall, respectively, m; l_z is the height of a casting wall, m; t is the time, s; r is a

variable of a radius; R is a radius of a riser, m; H_p is the height of a riser, m; $q_{x,0}$, $q_{y,0}$, $q_{z,0}$ are the densities of a heat flow in x , y and z directions, respectively, W/m^2 ; λ_1 is an effective ratio of liquid metal heat conductivity, $W/(m \cdot K)$; $q_{r,0}$ is the density of a heat stream in radius' direction, W/m^2 ; ε is an effective degree of body blackness; σ is the Stefan-Boltzmann constant, $W/(m^2 \cdot K^4)$; T_a is the temperature of environment, K; T_k is the temperature of the marginal metal layer, K.

A calculation method for cooling of metal, flowing in the mould cavity, was created as well. According to this model, a finite portion of metal under initial conditions (Equations 6 and 11) goes into the mould cavity and, while flowing, gives the superheat away during contact with walls of a casting in x and y directions. Radiated heat from the open metal surface in z direction is estimated, too, while metal is being poured into a mould. According to this model, it is possible to calculate cooling of metal for castings that have elements of different cross-section, and different speed of metal flow is estimated in each element. After mould pouring, a temperature gradient and initial conditions (Equations 5 and 10) are found for the further calculation of cooling in a casting.

A program was created for volumes changes of a cooling casting. Using a net method, a casting is divided into finite elements of constant volume. When calculations are made in finite time Δt , temperature change of each element is found. General volume change of a casting in a time period is:

$$\Delta V_i(t) = (T_{pr} - T) \cdot V_i \cdot \alpha_v; \quad (12)$$

$$\Delta V(t) = \sum \Delta V_i(t), \quad (13)$$

where $\Delta V_i(t)$ is the volume change of a finite element in time Δt ; $\Delta V(t)$ is the volume change of the whole casting in time Δt ; T_{pr} is the temperature of a finite element at the beginning; T is the temperature of a finite element at the end; V is the volume of a finite element; α_v is the temperature-dependent shrinkage rate of a liquid alloy.

The whole volume change of a casting in time Δt is transformed into volume change in a riser, i.e. it is calculated in what size Δh the level of liquid metal decreases. Moreover, when the level of liquid metal changes in a riser, the thickness of a frozen metal crust $\Delta \delta$ is estimated as well (Fig. 1).

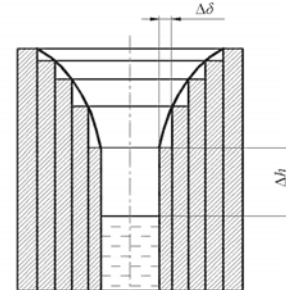

Fig. 1. A shrinkage calculation scheme in finite time Δt

On the base of this mathematical model, a computer program was created for calculation of heat exchange in a cooling casting and volume shrinkage of metal. This program helps to simulate the formation of a shrinkage cavity in a riser.

When technological conditions and physical parameters are changed in that way, it is possible to simulate the formation of a cavity in a riser of a casting, and to find the best dimensions of a riser for the simulated casting.

EXPERIMENTAL

Density of melted ductile iron and temperature-dependent volume shrinkage rate were found in the method of hydrostatic weighing when a graphite buoy was submerged into liquid metal, and density was found according to the lifting force of metal [12].

Experimental cast iron was melted in the induction metal melting furnace IST-016. The charge consisted of steel scrap, return scrap, carburizing agent, and ferro-silicon. Spheroidizing inoculation of cast iron was made using master alloy with (10 – 12) % Mg in the method of pouring. In 3 minutes after inoculation, metal was poured into a casting mould.

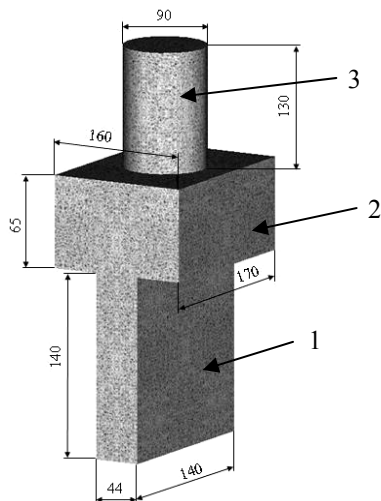

Fig. 2. An experimental casting: 1 – the first element of the casting; 2 – the second element of the casting; 3 – a riser

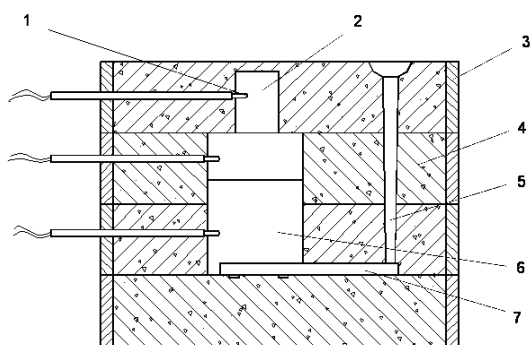

Fig. 3. An experiment scheme to test a mathematical model for cooling of a casting: 1 – a thermocouple of platinum and platinum-rhodium; 2 – a riser; 3 – a flask; 4 – a mould; 5 – a downsprue; 6 – a mould cavity; 7 – a drag runner

Experimental castings had two elements of different cross-section and a riser (Fig. 2). When such casting is made, a shrinkage cavity forms in its most massive part. Therefore, a riser is added to the most massive element. The initial size of the riser is chosen in an empirical method, when total metal shrinkage during casting is

calculated. In order to be the most effective, the riser is put on the upper part of a mould. Later on, when a cooling casting is simulated, optimal dimensions of the riser are found.

Three thermocouples of platinum and platinum-rhodium were put into the casting mould in order to measure the temperature of the cooling casting: in the riser and in different elements of the casting (Fig. 3). The change of temperature in time period was put down by the potentiometer EPP-09M.

RESULTS AND DISCUSSION

After calculation of volume shrinkage of the casting (Fig. 2), the size and shape of a shrinkage cavity in the riser of the casting were found (Fig. 4). In order to avoid an area of porous metal below the shrinkage cavity penetrating into the casting, height of the riser was increased in 1/3 part.

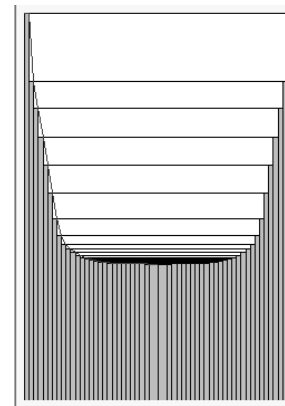

Fig. 4. Simulation results of a shrinkage cavity in the riser

In the experiment, metal pouring temperature was 1300 °C. Pouring into a mould took 20.5 s. The calculated pouring into a mould had to take 18.5 s. It happened so because it is difficult and sometimes impossible to pour metal out of a ladle evenly.

Temperatures of the cooling casting are given in Figure 5. The results show that a big temperature gradient appeared in the casting after pouring into the mould. Metal temperature in the riser was the lowest – 1247 °C, and temperature of liquid metal in the casting element, which connects to ingates, was the highest – 1295 °C.

When the casting was cooling, temperature decreased the most rapidly in its first element, and the most slowly in the riser because the first element has the smallest relevant wall thickness, and the riser has the biggest one. The smaller the relevant wall thickness, the more intensive the heat exchange. Moreover, when heat exchange becomes more intensive, sedimentation of crystal centres begins in melted metal because they have higher density than melted metal. When crystal centres settle down on the lowest part of the mould, they push liquid metal to the top, i.e. to the riser. Temperatures of different elements of the casting, calculated according to the mathematical model, are given in Figure 6. This figure shows that calculated temperatures of cooling metal until crystallization were changing similarly.

The calculated liquid metal needed for feeding of a cooling casting is given in Figure 7. The biggest metal

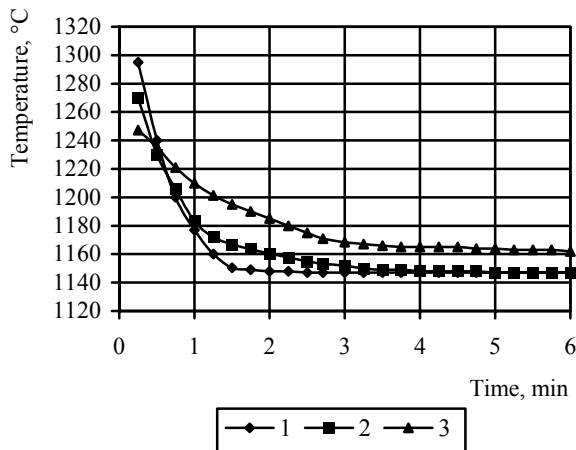

Fig. 5. Temperature of the cooling casting during the experiment: 1 – in the first element of the casting; 2 – in the second element of the casting; 3 – in the riser

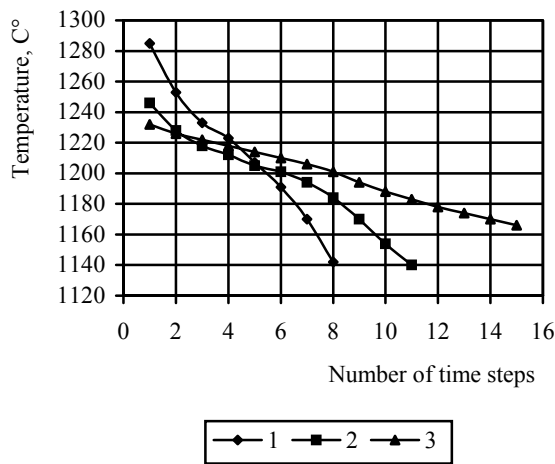

Fig. 6. The calculated temperature change in the different elements of the cooling casting: 1 – the first element; 2 – the second element; 3 – the riser; a time step $\Delta t = 15$ s

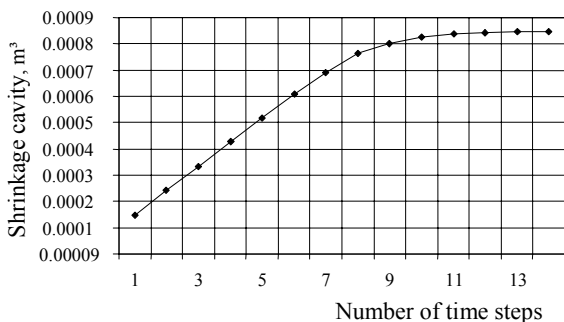

Fig. 7. Volume increase of a shrinkage cavity calculated according to the mathematical model; a time step $\Delta t = 15$ s

need and the biggest shrinkage appear at the initial stage of cooling. At this moment, there is the biggest temperature gradient and the most rapid heat exchange between liquid metal and a mould. At the further stage of cooling, a temperature gradient decreases significantly, and a metal crust begins to form, decreasing the amount of liquid phase in a casting. Therefore, liquid metal need for a cooling

casting begins to decrease. Such liquid metal need for feeding of a cooling casting creates a funnel-shaped shrinkage cavity.

The experimental castings were knocked out of the mould, cleaned and observed visually (Fig. 8). They had no shrinkage defects on the surface, and the risers had deep shrinkage cavities.



Fig. 8. The experimental casting

The risers were cut off the castings, and the surface of the castings was even, without any defects. The risers were cut in the longitudinal axis with the help of a milling machine, for the visual investigation of a shrinkage cavity. The riser section is shown in Figure 9. Its comparison with the simulated riser (Fig. 4) shows that the theoretical cavity shape defines the cavity shape in the riser section rather accurately. An area of porous metal is a little bit larger than the theoretical cavity but there are no shrinkage defects in the casting. It is necessary to remember this area in riser simulation. This area forms during crystallization, when a frame of solid crystals has already grown, and filtration of liquid metal is very small through it. Therefore, it is necessary to increase height of a riser for about 10 % of height of the simulated shrinkage cavity.



Fig. 9. The longitudinal section of the riser

Correspondence of the mathematical model to a real process was tested using software “Statistica”. The change of metal temperature in different elements of the casting during cooling was chosen for statistical evaluation. Correlation between the experimental change of metal temperature in time period and the change of average

temperatures in each element of the casting, calculated according to the mathematical model, was estimated.

With a confidence interval of 95 %, there is a good correlation between the experimentally measured temperatures and calculated average temperatures. A correlation rate for different elements of the casting changes from 0.906 to 0.982. A big correlation rate shows that the created mathematical model can be used for cooling simulation of a casting.

CONCLUSIONS

1. A mathematical model was created for calculation of heat exchange and crystallization rate in a casting. The model estimates heat exchange and, consequently, temperature gradient and volume shrinkage of metal during mould pouring. Calculations estimate heat exchange in the form of conductivity, radiation and convection.
2. A program for calculation of cooling and volume changes in a casting was created and tested experimentally. This program helps to change technological conditions of casting, and to simulate cooling of a separate casting and volume shrinkage of metal. Simulation of shrinkage lets to eliminate test castings and to find optimal dimensions of a riser for the lowest metal consumption.

REFERENCES

1. **Campbell, J.** Castings. Butterworth-Heinemann Ltd, Oxford, 1993.
2. **Zacharchenko, Eh. V., Levchenko, Ju. N., Gorenko, V. G., Varenik, P. A.** Iron Castings with Spheroidal and Vermicular Graphite. Naukova Dumka Publishers, Kiev, 1986 (in Russian).
3. **Shebatinov, M. P., Abramenko, Ju. E., Bekh, N. I.** Ductile Iron in the Production of Motor Car. Mashinostroyeniye Publishers, Moscow, 1988 (in Russian).
4. **Vashhenko, K. I., Shumikhin, V. S.** Melting and Treatment of the Castings' Iron. Vishha shkola publishers, Kiev, 1992 (in Russian).
5. **Karsay, S. J.** Ductile Iron Production Practices. Am. Foundrym. Soc. Inc. Des Plaines, Ill., 1994.
6. **Galdin, N. M., Chistjakov, V. V., Shatul'skij, A. A.** Gating Systems and Risers of Complex Castings. Mashinostrojenije publishers, Moscow, 1992 (in Russian).
7. **Swaminathan, C. R., Voller, V. R.** Towards a General Numerical Scheme for Analysis of Solidification Systems *International Journal of Heat and Mass Transfer* 40 1997: pp. 2859 – 2868.
8. **Denisov, V. A., Kosteneckij, S. V., Oshurkov, A. T., etc.** Calculation of Risers of Steel Castings Using ECM *Foundry* 10 1988: pp. 17 – 18 (in Russian).
9. www.magmasoft.com
10. **Calcaterra, S., Campana, G., Tomesani, L.** Prediction of Mechanical Properties in Spheroidal Cast by Neural Networks *Journal of Materials Processing Technology* 104 (1 – 2) 2000: pp. 74 – 80.
11. **Beszterda, B., Drgas, T.** Optimization of the Rims 500/600 Production Technology by the Simulation of Casting and Solidification Processing *Survey of Foundry* 5 (9 – 10) 2001: pp. 351 – 354 (in Polish).
12. **Bočkus, S., Dagys, V., Venckūnas, A., Žaldarys, G.** Density and Linear Contraction of Cooling Ductile Iron *Materials Science (Medžiagotyra)* 7 (4) 2001: pp. 252 – 255.

DOI: 10.5755/j02.ms.26481