

Efficient Mix Design Method and Main Properties of Composite Material

Nerijus ADOMAVIČIUS^{1*}, Albinas GAILIUS², Ingrida GIRNIENĖ³

¹Firefighter Training School, R. Jankausko 2/28, LT-04310 Vilnius, Lithuania

²Department of Building Materials, Vilnius Gediminas Technical University,
Saulėtekio al. 11, LT-10223 Vilnius, Lithuania

³Vilnius College of Construction and Design, Antakalnio str. 54, LT-10303 Vilnius-55, Lithuania

Received 30 September 2004; accepted 19 October 2004

Examination of literature concerning methods of designing the compositions of composite materials shows that these methods, most of which are empirical and based primarily on a large number of experimental studies and lead to conclusions that, seem to us, to be limited and will suited to the composite material that fiber reinforced composite material is. This paper presents the results of a study on development of compositions having all rheological properties required for composite materials. The fiber reinforced composite is made of matrix and fibers. A high modulus polyethylene fiber was used as the reinforcing fiber. Fiber reinforced composite materials are highly heterogeneous compositions of the dispersion results are often large. To obtain usable information, we made a large number of tests on different specimens and then carrying out a statistical analysis of the results.

Keywords: concrete, fibers, polypropylene, matrix, rheological properties, composite materials.

1. INTRODUCTION

Plastic fiber reinforced composite materials are under investigation as improved concrete reinforcement by virtue of their promise of improved durability in comparison with conventional steel fibers. These kinds of materials consist of continuous different fibers in a concrete matrix [1]. The fibers are oriented at high volume fractions in the direction of significant stress. Properties of interest to designers offered by composites are high tensile strength, high damping, low weight, high fatigue strength, corrosion immunity and electromagnetic neutrality [2]. Over the last few years, produced fiber reinforced members, cast conventional concrete [3], were introduced into civil engineering structures including buildings, bridges and other infrastructures [4]. The safety and reliability of these fibers reinforced composite structures, being the new kinds of engineering structures, are always concerned [5].

A look at the literature on the mechanical behavior of fiber reinforced concrete composites shows that there is a shortage of information, most of it contradictory. The results presented by various researchers working in this field are often quite different. In reporting their tests, researchers generally fail clearly to, distinguish that which is relevant to the behaviour of the structure constituted by the test specimen [6]. This makes it very hard to isolate the influence of the fibers on the scale of the material from their influence on the scale of the structure.

Intended industrial application requiring the fiber reinforced composites having specific properties will lead to a specific material having a specific composition optimized for those properties [7].

Some of the fibers which have been used extensively in the past include carbon, glass, natural fibers, different plastic fibers and steel [7, 8]. In the latter category, these

are abundant literature on the potential use of polypropylene, polyethylene, nylon or polyester fibers [4, 9]. Polypropylene fibers are more resistant to decay from the alkaline environment within concrete than the natural fibers and normal glass fiber. Considering the economical and corrosive reason, polypropylene fibers as reinforcement will be employed more widely in the near future [9, 10].

With respect to implementation of such composite materials and their potential use in low water – cement ratio mixtures, the question arises whether they can also provide performance advantages from the rheological point of view. Unfortunately, due to the complex composition of the material, no definite method for predicting the flow of fresh concrete from its components exists [2]. Even measurements of the rheological parameters are not easily performed due to the large range of particle sizes found in concrete. Therefore, the flow of a given concrete is usually measured using one of the many standard tests available that only partially measure the intrinsic flow properties of the material [11].

Investigation on the mechanical behaviour of fiber reinforced composites shows that there is no shortage of information, much of it contradictory. The results presented by various researchers working in this field are often quite different [12 – 16]. There are several reasons, but in our opinion, there are two main reasons for this:

– fiber reinforced composite material is not a single material, but as many composite materials as there are fields of application. This means that fiber reinforced composite material having specific properties will lead to a specific material having a composition optimized for those properties, which it would be pointless and misleading to compose with another, necessarily different, material.

– researches generally fail clearly to, distinguish that which is relevant to the behaviour of the material as such from that which concerns the behaviour of the structure constituted by the tested specimen.

*Corresponding author. Tel.: +370-5-2402802; fax: +370-5-2402802.
E-mail address: toris@boo.lt (N. Adomavičius)

In such way it is hard to prevent the influence of the fibers on the scale of the material from their influence on the scale of the structure.

The purpose of this research was to investigate proposed method of composition based on optimization the granular skeletons of ordinary heavy concrete:

- fixed at the outset the percentage of fibers to be incorporated;

- for fixed water – cement ratio, the most workable, fresh concrete is the most compact and structure of its mineral skeleton is optimal;

- the fine aggregate – coarse aggregate ratio is varied starting from the composition of a test concrete that does not contain fibers;

- variation of fine aggregate – coarse aggregate ratio and determination of the workability of fiber reinforced composite at each ratio.

2. MATERIALS FOR COMPOSITE

Methods of designing the mix of fiber reinforced compositions show that most of them [1] are based on a large number of experimental tests and seems to us to be limited and ill – suited to the composite material that fiber reinforced concrete is.

The matrix materials were: cement, coarse aggregates, fine aggregates, water. Portland cement CEM I 42.5 R grade, manufactured by “Akmenes cementas” Joint – stock Company, was used as a binding material. Initial setting time of Portland cement is 120 min, final setting time – 180 min. Its chemical composition complies with the LST 1155:1996 specifications, while mineralogical composition of the clinker is respectively as follows: C₃S – 60.04 %, C₂S – 11.81 %, C₃A – 8.59 % and C₄AF – 10.78 %. This cement has the quality certificate № 10/2. Chemical composition of Portland is cement presented in Table 1.

Table 1. Chemical composition of raw materials

Raw materials	Composition, %						L.O.J., %
	SiO ₂	Al ₂ O ₃	Fe ₂ O ₃	CaO	MgO	SO ₃	
Portland cement	19.92	5.51	3.55	64.46	3.98	2.38	0.2
Sand	83.67	4.65	0.95	5.41	0.93	–	4.39

The properties of aggregate which are considered to have an effect on the workability of concrete mix are the grading, including the maximum size. On the other hand maximum size is usually governed by the size of the members to be cast on the spacing between the reinforcement of the cover.

The fine aggregate used was natural sand, whose fineness modulus was 2.80 and the maximum size was less than 5 mm. Chemical composition of sand presented in Table 1. The coarse aggregated are defined as the crushed Lithuanian dolomite particles size 10, 15 and 20 mm respectively.

The purpose of this complementary testing was:

- to conform the effect of different types of fibers.

Four different types of polypropylene fibers were used:

- T-1 the form of the first type (T-1) of roughen fiber was rounded;

- T-2 the same fiber as T-1 was processed by special machine. The surface of the fibers was modified through mechanical abrasion process. This process consisted of mixing the polyethylene fibers with the sand to be used in the composition before addition of the cement and water. It was observed under the microscope that this operation modified the rougher, without slitting the fibers along their length;

- T-3 rounded fibers with waviness surface;

- T-4 fibers are like spiral. During preparing concrete mix the fiber spiral is under tensile and become in pre-stressed state.

Table 2. Properties of polypropylene fibers used in the research

Fiber Denomination	Specific gravity, g/cm ³	Length, mm	Diameter, mm	Tensile strength, MPa
Polypropylene T-1	0.91	12	0.03	0.68
Polypropylene T-2	0.91	12	0.033	0.62
Polypropylene T-3	0.91	12	0.037	0.55
Polypropylene T-4	0.91	12	0.03	0.60

The physical and mechanical properties of four different types of polypropylene fibers are shown in Table 2.

3. RESULTS AND ANALYSIS

3.1. Optimization of mix compositions

Analysis of different methods of designing the compositions of fiber reinforced composites shows, that these methods, most of which are empirical and based primarily on a large number of experimental test, used for ordinary concretes [2].

In this article, we proposed, as seem to us method suitable to the composite material that fiber reinforced concrete is. This method is based on assumptions that have been amply confirmed by experimental tests:

- varied the fine aggregate and course aggregate ratio and determined the workability of the fiber – reinforced composites mixtures at each ratio. This allows to plot workability is greatest;

- to increase or decrease the quantity of water and cement, while holding the water - cement ratio constant to obtain the desired workability.

The fine – coarse aggregate ratio is started from the composition of control mixture that does not contain fibers. This control composition contains the same cement, the same aggregate constituents, the same water – cement ratio as the fiber reinforced composition.

All mixtures are plasticized. Super plasticizer Daracem SP1 (Grace construction products, Cheshire, United Kingdom) was used. It is based on the soluble salt of polymeric naphalene sulphonate and conforms to type

A, D and F materials of ASTM designation C 494 [3]. A quantity of super plasticizer is fixed at the outset, in the first stage of optimization of the composition. In the second stage, the quantity of the super plasticizer is varied at the same time as the quantities of water and cement to obtain desired workability.

Some researchers kept the quantity of binder constant and equal to the quantity in the control composition. Their choice leads to having higher water – cement ratios and containing less binder [4].

The second important step in optimization composition is determination the workability of mixture.

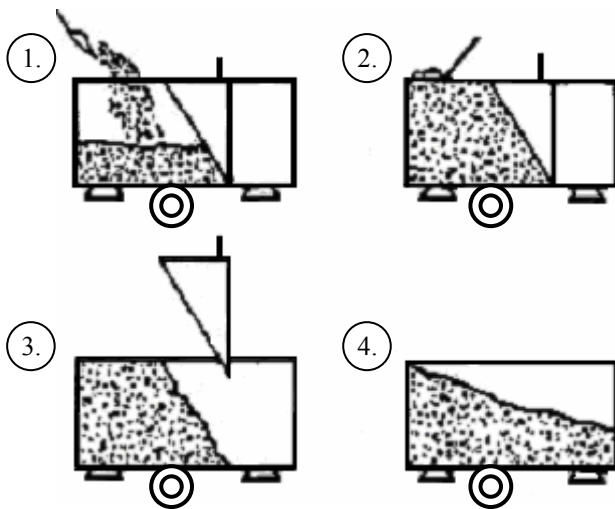

Fig 1. Successive stages of the test in the Workabilimeter: (1) filling of mould; (2) striking off; (3) removal of wedge (vibrator and chronometer started); (4) concrete reaches mark on end plate (chronometer stopped)

Very important to measure significant slumps with fiber reinforced composites, making the determination of the optimum fine – coarse aggregate ratio precisely. In experimental research we used modified Workabilimeter developed by Lesage [2]. This device characterizes the workability of the concrete by a flow time in the presence of external vibration. This Workabilimeter can test 25 – 30 liters of composite mixture (five times as much as the Abrams cone). The device is open sectauguber mould with an external vibrator (the rate of vibration 50 Hz). Removable vertical partition divides mould into two compartments. One compartment is filled by testing

Table 3. Compositions of fiber reinforced composites

No of composition	Cement, kg/m ³	Water, kg/m ³	Water / cement ratio	Fine aggregate kg/m ³	Coarse aggregate, kg/m ³	Fine/coarse aggregate ratio	Super plasticizer, %
C-1	300	135	0.45	660	1320	0.50	1.25
C-2	325	146	0.45	750	1200	0.60	1.0
C-3	350	157	0.45	780	1070	0.73	0.75
C-4	375	169	0.45	945	908	1.04	0.5
C-5	400	180	0.45	920	782	1.18	0.75
C-6	425	191	0.45	890	660	1.35	1.0
C-7	450	202	0.45	950	575	1.55	1.25

material. Fig. 1. is a schematic diagram of the test showing the various stages of the procedure used to determine the workability of a mixture. The wedge is removed and the mold is vibrated. The time the concrete takes to flow to fixed mark is measured.

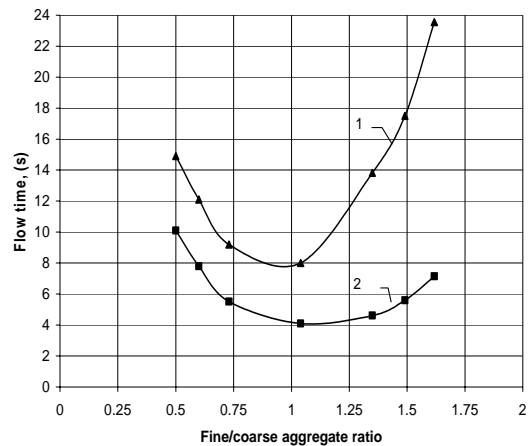

Fig 2. Determination of the optimal fine/coarse aggregate ratio: C-1 composition (Table 3). Super plasticizer: 1 – 0 %; 2 – 1.25 %

Fig. 2 shows the first stage of optimization of fine-coarse aggregate ratio. It can be seen that the position of the optimum is the same in curves 1 and 2. The super plasticizer reduced flow time (Fig. 2., curve 2). Table 3 gives the optimum compositions of fibre reinforced composite.

3.2. Rheological and mechanical properties of fiber reinforced composites

Due to the complex composition of the material, no definite method for predicting the flow of concrete from its components exists.

The composite material, like concrete, is a concentrated suspension of solid particles in a viscous liquid. In this case equation (1) is applicable:

$$\frac{F}{A} = T = \eta \cdot v, \quad (1)$$

where F is the shear force, N; A is the area of plane parallel to force, mm²; T is the shear stress, Pa; η is the flow (viscosity), Pa·s; v is the shear rate, dv/dy .

Table 4. Influence of mix composition and type of fibers on rheological and mechanical properties of composite

№ of composition	Flow time, s					Compressive strength, MPa				
	Type of fiber					Type of fiber				
	T-1		T-2	T-3	T-4	T-1		T-2	T-3	T-4
	Amount of super plasticizer					Amount of super plasticizer				
0 %	1.25 %				0 %	1.25 %				
C-1	14.9	10.1	14.7	16.2	18.8	50	54	53	56	49
C-2	12.1	7.8	12.8	13.4	15.3	44	49	47	49	47
C-3	8.9	4.9	9.1	9.7	11.4	43	44	46	47	44
C-4	8.0	4.1	9.0	9.4	11.3	46	48	42	48	46
C-5	14.1	4.2	15.3	15.2	16.6	38	39	44	41	45
C-6	18.2	5.9	19.9	21.0	20.7	34	35	46	37	44
C-7	23.9	7.2	5.1	26.6	27.5	37	31	39	32	39

Table 4 shows the influence of fibres types at a constant percentage of incorporated fibers (1.25 %) average of 3 tests. It can be seen that with 1.25 % incorporated fibres the results with different types of fibers are comparable. Such results are in our opinion explained by the method of mix composition used in research, which leads to cement paste matrices and thus very good adherence between the fibers and the matrix.

For compressive strength tests the specimens were cast in 100×100×100 mm molds. All specimens were hardened at temperature 20 ±2 °C, relative humidity 95 % for 28 days.

Compressive strength results for the various composite mixtures at 28 days are shown in Table 4.

The fiber reinforced composite materials are highly heterogeneous composite materials. For this reason the dispersion of the results is often large. To obtain usable information – need very large number of tests on small test specimens and then carrying out a statistical analysis of the results. Another way conducting a three tests on large specimens – for each mixture – testing on a scale on which the dispersion becomes small.

Compressive strength values all of the fibre reinforced composites are higher than strength values specimens without fibres. 1.25 % of fibres by composite volume is the optimum [8]. A way to explain the higher compressive on the basis on composites theory [1], that adding fibers to a cement matrix strengthening it by additional reinforcement. A Table 4 shows that fine – coarse aggregate ratio (F/C) is approximately the same for reinforced and ordinary coruposites. The results also show that optimum of F/C = 1.04 for flow time of mixture also is optimum for compressive strength of composite.

4. CONCLUSIONS

- The methodology of design of compositions of fibre reinforced composites is quite different from the composition of an ordinary composite.
- The methods of composition used in recent study leads to containing sufficient amount of cement paste, which

has a high effect on bonding between the fibers and the matrix.

- The use of four types of fibers (1.25 % by volume) leads to improve compressive strength of composite material.
- The more effective influence on compressive strength of composite are two types of fibers – T-2 and T-3.
- Since polypropylene fibers are durable in the alkaline environment of cement – based matrices and since they impart mechanical properties to the composite, their use should be explored particularly in thin sheet applications.
- Additional studies are recommended to evaluate whether the improved performance of polypropylene composites can be economically justified when compared to the composites at 1.25 % modified fiber content.

REFERENCES

1. **Rossi, P., Acker, P, Malier, Y.** Effect of the Steel Fibers at Two Different Stages: the Material and the Structure *Mater. Struck Engineering Materials and Structures: a Few Remarks* ibid. 22 1989: pp. 28 – 34; 21 1988: pp. 3 – 12.
2. **De Larrard, F.** Mix-design Method for High-Strength Concrete *Supplementary paper. 3rd International Conference on Silica-Fume, Fly Ash, Silica-Fume and Natural Pozzolans in Concrete*, Trondheim, Norway, 1989.
3. **Pailhere, A., Godart, B.** Contribution des fibres metalliques a l amelioration du comportement des structures en beton *In: Proceedings of 1st International Rilem Congress Combining Materials: Design, Production and Properties* Vol. 2. Chapman and Hall, 1987: pp. 686 – 693.
4. **Fischer, A. K., Bullen, F., Beal, D.** The Durability of Cellulose Fibre Reinforced Concrete Pipes in Sewage Application *Cement and Concrete Research* 31 (4) 2001: pp. 543 – 553.
5. **Blankenhorn, P. R., Blankenhorn, B. D., Silsbee, M. R., DiCola, M.** Effects of Fiber Surface Treatments on Mechanical Properties of Wood Fiber-Cement Composites *Cement and Concrete Research* 31 (7) 2001: pp. 1049 – 1055.

6. **Biricik, H., Akoz, F., Turker, F., Berktaş, I.** Resistance to Magnesium Sulfate and Sodium Sulfate Attack of Mortars Containing Wheat Straw Ash *Cement and Concrete Research* 3 (8) 2000: pp. 1189 – 1197.
7. **Blankenhorn, P. R., Silsbee, M. R., Blankenhorn, B. D., DiCola, M., Kessler, K.** Temperature and Moisture Effects on Selected Properties of Wood Fiber-Cement Composites *Cement and Concrete Research* 29 (5) 1999: pp. 737 – 741.
8. **Kazragis, A., Gailius, A., Juknevičiūtė, A.** Thermal and Acoustical Insulating Materials Containing Mineral and Polymeric Binder with Cellulose Fillers *Materials Science (Medžiagotyra) ISSN 1392-1320* 8 (2) 2002: pp. 193 – 195.
9. **Kazragis, A., Gailius, A., Tamulaitienė, B., Kulinič, H.** Utilization of Straw and Reed in Building Product Fabrication *Environmental Engineering (Aplinkos inžinerija) ISSN 1392-1622*, 10 (2) pp. 77 – 83 (in Lithuanian).
10. **Savastano, H., Warden Jr., P. G., Coutts, R. S. P.** Ground Iron Blast Furnace Slag as Matrix for Cellulose-Cement Materials *Cement and Concrete Composites* 23 (4 – 5) 2001: pp. 389 – 397.
11. **Qijun, Yu, Sawayama, K., Sugita, S., Shoya, M., Isojima, Y.** The Reaction Between Rice Husk Ash and $\text{Ca}(\text{OH})_2$ Solution and the Nature of Its Product *Cement and Concrete Research* 29 (1) 1999: pp. 37 – 43.
12. **Cisse, I. K., Laquerbe, M.** Mechanical Characterization of Filler Sandcrete with Rice Husk Ash Additions *Cement and Concrete Research* 30 (1) 2000: pp. 13 – 18.
13. **Savastano, H., Warden Jr., P. G., Coutts, R. S. P.** Brazilian Waste as Fibres as Reinforcement for Cement-Based Composites *Cement and Concrete Composites* 25 (5) 2000: pp. 379 – 384.
14. **Singh, N. B., Singh, V. D., Rai Sarita, Chaturvedi, Shivani.** Effect of Lignosulfonate, Calcium Chloride and Their Mixture on the Hydration of RHA-Blended Portland Cement *Cement and Concrete Research* 32 (3) 2002: pp. 387 – 392.
15. **Sebok, T.** Relationships Between the Properties of Lignosulphonates and Parameters of Modified Samples with Cement Binders *Cement and Concrete Research* 30 (4) 2000: pp. 511 – 515.
16. **Coutts, R. S. P., Ni, Y.** Autoclaved Bamboo Pulp Fibre Reinforced Cement *Cement and Concrete Composites* 17 (2) 1995: pp. 99 – 106.

DOI: 10.5755/j02.ms.26482