

The Influence of Cement Particles Shape and Concentration on the Rheological Properties of Cement Slurry

Gintautas SKRIPKIŪNAS^{1*}, Mindaugas DAUKŠYS¹,
Arminas ŠTUOPYS¹, Rimantas LEVINSKAS²

¹Dept. of Building Materials, Kaunas University of Technology, Studentų 48, LT-51367 Kaunas, Lithuania

²Lithuanian Energy Institute, Breslaujos 3, LT-44403 Kaunas, Lithuania

Received 06 August 2004; accepted 19 March 2005

The results of the experimental investigation of the influence of various types of cements – Portland cement and ground granulated blast furnace slag cement (GGBS cement) on the cement slurries yield stress, viscosity and dilatancy are presented in the paper. Rheological properties of the cement slurries and cement particles shape and surface texture were tested. The dilatancy of the cement slurries was evaluated by the form of the flow curves and by the calculated dilatancy factor. It was established, that particles of slag cement are more angular, what have great influence on yield stress and viscosity of cement slurry. The yield stress of GGBS cement slurry is about 1.8 times and 1.6 times respectively greater than Portland cement slurry. The yield stress and viscosity of GGBS cement slurry increases about 2 times more than this of the slurry of Portland cement with increasing the cement volume concentration. The changes of the cement slurry viscosity and yield stress could be described by exponential equation, which must be modified with the coefficients, depending on cement particles shape and volumetric distribution. The values of these coefficients for the Portland cement and slag cement were determined during this investigation.

Keywords: Cement, slurry, particles shape, concentration, yield stress, viscosity, viscometer, dilatancy

1. INTRODUCTION

Rheological properties usually are very important to cement slurry, mortar and concrete mixture in a plastic state. Rheological properties for a mixture are chosen according to the technology of the construction works and according to the equipment used. This is extremely important while using the most modern building technologies, e.g. supplying mixtures by concrete pumps, using self-compacting mixture etc. Cement slurry, mortar and concrete mixture are denoted to Bingham bodies (systems), flow of which is described by two rheological parameters – yield stress τ_0 and structural viscosity η . The flow curve of those mixtures, which demonstrates shear rate dependency upon shear stress, is a straight line inclined by a certain angle onto the τ axis. Yield stresses are such stresses, having which the structural liquid starts to flow. They are found by the point of crossing of the flow curve with τ axis [1 – 3].

In previous investigations [4 – 8] it was found that the Bingham model, which is suggested for describing cement slurry flow curves, is not precise. The dependency of flow of those slurries is not straight, as it is in Bingham model, but it becomes a curve while increasing share stress. This demonstrates that cement slurry is characterized by dilatancy, i. e. viscosity of the system is increasing when the shear stresses are increasing. According to O. Reynolds, this increase of viscosity is caused by growth in volume of the dispersive system because of the change of distribution of the phase particles, while some particles move in regard to other, and by relative decrease in volume of dispersive medium. [9].

Cement slurry and concrete mixture rheological properties are tested by various viscometers, which differ in their working principle [10 – 14]. The most often rotational viscometers with coaxial cylinders are used.

In practical aspect the rheological properties are useful, because they make possible prognosis of the technological characteristics of the cement slurry, mortar and concrete mixture with the corresponding cement – i.e. consistence, possibility to flow, possibility to be supplied by pumping.

These tests are aimed to evaluate influence of cement particles shape and concentration on yield stresses, viscosity and dilatancy of Portland cement and GGBS cement slurries and to make more precise the theoretical models which are used to describe these rheological properties of cement slurries.

2. BACKGROUND

The cement slurry, mortar and concrete mixture are dispersive systems, whose dispersive media is water, and cement particles, fillings or mineral additives make a disperse phase. Very small particles and water give to a dispersive system binding characteristics, on which the system structure and rheological properties depend. Viscosity of a dispersive system is greatly influenced by concentration of the disperse phase and the particles shape. Dispersive systems are characterized by thixotropy [15] and dilatancy [4 – 8], i.e. their characteristics depend on mechanical impact. Thixotropy most of all appears during vibration, when there is decrease in the system shear stresses and viscosity. Dilatancy appears when the system viscosity is increasing during the increase of shear stresses.

Relation between the suspense viscosity η and concentration of the solid (spherical) particles volume

*Corresponding author. Tel.: +370-37-455120; fax.: +370-37-300465.
E-mail address: gintautas.skripkiunas@ktu.lt (G. Skripkiūnas)

concentration ϕ (the volumetric fraction of solid material with respect to a total volume of one) at first was described by a well-known Einstein equation [16, 17]:

$$\eta = \eta_0(1 + 2.5\phi), \text{ [Pa}\cdot\text{s]} \quad (1)$$

where: η_0 is the viscosity of the liquid phase, [Pa·s]; ϕ is the volume concentration of solid particles.

This straight dependency is true only for liquid suspense of low concentration. Later after evaluation of the interaction of solid particles in suspension as mentioned in [17] by R. Roscoe applied this dependency to more concentrate suspension:

$$\eta_r = (1 - 1.35 \cdot c)^{-2.5}, \quad (2)$$

where: $\eta_r = \frac{\eta}{\eta_0}$ is the relative viscosity; c is the solid particles concentration.

In these formulas concentration of the solid particles is presented without taking into consideration the particle size distribution, which is a feature of cement and mineral additives.

After discussions with G. Karam, J. Murata and H. Kikukawa [18] it was suggested this equation for prediction of viscosity of the cement slurry:

$$\eta_r = \left(1 - \frac{1}{C(V)} \cdot V\right)^{-K(V)}, \quad (3)$$

where: $C(V)$ is the limit particle concentration, in which the slurry stops flowing because of the particles interaction in places of their contacts, V is the solid particle volume concentration; $K(V)$ is the Einstein or particle shape coefficient for spherical particles is 2.5 and for prolonged, eclipse or bar shape particles this coefficient is greater.

According to G. Karam the coefficient $C(V)$ can be equal to cement particle volume concentration when they are in dry bulk condition. According to the author the coefficient $K(V)$ depends on particle length to diameter ratio L/D [18]. This coefficient can be equal even 10, if $L/D = 16$. In this case cement particles limit concentration in the suspension decreases to 0.31 and such slurry becomes non-flowing.

Other authors [19] suggest Kreiger-Dougherty equation for evaluation of viscosity of dispersive systems:

$$\eta_r = \frac{\eta}{\eta_0} = \left(1 - \frac{\phi_s}{\phi_M}\right)^{-[\eta]\phi_m}, \quad (4)$$

where: ϕ_s is the solid particle volume concentration; ϕ_M is the solid particle maximum volume concentration, depending on the particles size, shape and surface $[\eta]$ is the coefficient, which was called by the authors of the article as “intrinsic viscosity of the particles”. When the shear stresses are low, i.e. a dispersive system is almost in a static state, location of its particles is close to random and ϕ_M is close to 0.63, then $[\eta] = 2.5$, as is the same as Einstein coefficient $K(V)$ for diluted suspensions. When shear stresses are greater, volume distribution of the particles changes and ϕ_M value reaches 0.74.

K. Asaga and D. M. Roy [17] after experimentally investigation of cement slurry, found dependency of yield stress upon cement volume concentration:

$$\tau_0 = A_0 \alpha^{(V_c - 0.5)}, \text{ [Pa]} \quad (5)$$

where: τ_0 is the yield stress, [Pa]; A_0 , α are the coefficients, depending on particle diameter and shape; V_c is the cement volume concentration.

Tests carried out by the authors showed that cement slurry yield stresses, as well as viscosity, are increasing, while cement volume concentration is increased. But according to the authors themselves, because of the small data pool, this dependency is not precise and some additional data is necessary to make it more precise.

For determination slurry viscosity J. Murata and R. M. Kondo [17] suggested exponent dependency:

$$\eta = B_0 \exp(K_1 V_c + K_2), \text{ [Pa}\cdot\text{s]} \quad (6)$$

where: B_0 , K_1 , and K_2 are the constants; V_c is the cement volume concentration.

Exponential Mooney function for prediction of viscosity of dispersive systems is widely used by many authors [20 – 24]. After applying this equation for cement slurry we get such an expression for its viscosity:

$$\eta_{ct} = \eta_v \cdot \exp\left(\frac{a_c \phi_c}{1 - b_c \phi_c}\right), \text{ [Pa}\cdot\text{s]} \quad (7)$$

where: η_{ct} , η_v are the cement slurry and water viscosities, [Pa·s]; ϕ_c is the cement volume concentration cement slurry; a_c is the coefficient, evaluating cement particle shape; b_c is the coefficient, depending on cement particles volume distribution density in cement slurry. Coefficient of particles shape a is equal to the Einstein coefficient K , which for particles of round shape is equal 2.5, and for particles of irregular shape it is equal 2.6.

Cement volume concentration in cement slurry is calculated using the equation [25]:

$$\phi_c = \frac{\rho_v}{\rho_v + \frac{V}{C} \rho_c}, \quad (8)$$

where: ρ_v , ρ_c are the water and cement densities, [kg/m³]; V/C is the water to cement ratio.

Coefficient of cement particle volume distribution density in cement slurry b_c is calculated using the equation [25]:

$$b_c = \frac{\rho_c}{\rho_c^{p'} \cdot \frac{\phi_c}{1.1 \cdot \phi_c^{nt}}}, \quad (9)$$

where: $\rho_c^{p'}$ is the cement dry bulk density in the state, after evaluation air sub-layers around the particles because of the roughness of their surface [25]:

$$\rho_c^{p'} = \rho_c^p (1 + 0.052(S_c - 0.15)^{0.27})^3, \text{ [kg/m}^3\text{]} \quad (10)$$

where: ρ_c^p is the cement dry bulk density, [kg/m³]; S_c is the cement specific surface area, [m²/kg]; ϕ_c^{nt} is the cement concentration in normal consistency cement slurry, which is possible to calculate using the equation [25]:

$$\phi_c^{nt} = \frac{\rho_v}{\rho_v + \left(\frac{V}{C}\right)_{nt} \rho_c}, \quad (11)$$

where: $\left(\frac{V}{C}\right)_{nt}$ is the water to cement ratio in normal consistency cement slurry.

Mooney dependency is used for calculating viscosity of other substances as well, e.g. for calcium sulphate suspension [26]. The authors state that the coefficient b_c is equal $\frac{1}{\phi_M}$, where ϕ_M is the maximum concentration of dry particles depending on their volumetric distribution. For spherical particles ϕ_M changes from 0.52 (when distribution of the particles is cubic) till 0.74 (when distribution of the particles is hexagonal). For the particles of irregular shape the value of ϕ_M is less.

3. EXPERIMENTAL PROCEDURE

For the test JSC “Akmenės cementas” Portland cement CEM I 42.5 and ground granulated blast furnace slag cement CEM III/B 32.5 N (GGBS cement), produced in CBR concern Lixhe factory (Belgium), having 66.2 % of ground granulated blast furnace slag, were used. Water requirements for normal consistency Portland cement slurry is 27.5 %, while for ground granulated blast furnace slag cement slurry is 30.9 %. Portland cement specific surface area is 353 m²/kg, particles density – 3110 kg/m³, dry bulk density – 1220 kg/m³. For GGBS cement correspondingly those characteristics are 450 m²/kg, 2960 kg/m³ and 1050 kg/m³. The cement slurry was mixed manually about 5 min. In the cement slurry W/C ratio was changing from 0.55 to 0.80. To avoid the sedimentation of cement particles, these slurries were continually mixed before testing.

Cement particles shape and surface microscopical tests were carried on using a scanning electron microscope JSM-5600 (firm JEOL). Cement slurries rheological properties were tested using rotational viscometer with coaxial cylinders BCH-3. The simplified scheme of the rotational viscometer is displayed on Figure 1.

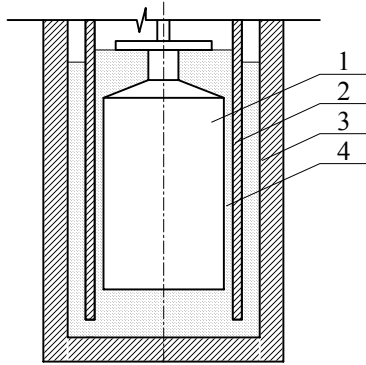

Fig. 1. Scheme of rotational viscometer with coaxial cylinders: 1 – cylinder connected with measuring scale; 2 – internal (rotating) cylinder; 3 – external (fixed) cylinder; 4 – cement slurry

The cement slurry is poured into a container (3) (external cylinder), which is fixed non-movably into the equipment stand. Inside the external the internal cylinder (2) can rotate. Because of the intrinsic friction of the layers of the cement slurry (4) appearing between the rotating

internal cylinder and the cylinder (1) positioned in the internal cylinder and connected to a measuring scale; the internal cylinder (1) makes a turn and the data displayed on the measuring scale changes. The gap between the rotating internal cylinder (1) and the cylinder inside it is 2 mm.

The cement slurry viscosity is tested at various speeds of the rotating cylinder – 200, 300, 400, 600 r.p.m. According to the scale display, the shear force F [mN] is calculated out on the calibration curve. The calibration curve depends on viscometer springs stiffness.

Shear rate $\bar{\gamma}$, for the different rotating speed of the cylinder (2), is calculated using the equation:

$$\bar{\gamma}_i = \frac{2\pi \cdot r \cdot n_i}{d_s}, [s^{-1}] \quad (12)$$

where: r is the radius of cylinder, connected to the scale, [m]; n_i is the cylinder rotation speed ($i = \overline{1,4}$), [r.p.m.]; d_s is the distance between the (1) and (2) cylinders, [m].

Shear stresses τ in cement slurry, are calculated using the equation:

$$\tau_i = \frac{F_i}{2\pi \cdot r \cdot h}, [Pa] \quad (13)$$

where: F_i is the shear force, calculated from the calibration curve according to the scale turning angle, [mN]; r and h are the radius and height [m] of the cylinder, connected to the measuring scale.

The viscosity of cement slurry η_i , is calculated using the equation:

$$\eta_i = \frac{\tau_i - \tau_0}{\gamma_i}, [Pa \cdot s] \quad (14)$$

where: τ_0 is the yield stress, found out of $\bar{\gamma} - \tau$ curve – the point, in which the curve crosses τ axis.

Cement slurry dilatancy is suggested to evaluate using the index D , which is calculated by increment of viscosity caused by shear stress increase using the equation [7, 8]:

$$D = \frac{\Delta\eta}{\Delta\tau}, \left[\frac{Pa \cdot s}{Pa} \right], \quad (15)$$

where: $\Delta\eta$ and $\Delta\tau$ are the cement slurries viscosity [Pa·s] and shear stresses [Pa] differences, when the shear rate are 630 1/s and 205 1/s.

4. TESTS RESULTS

Portland cement slurries with different W/C ratio have rheological curves shown in the Figure 2. From these curves we can see that while W/C ratio is increasing, yield stress of Portland cement slurry are decreased. According to the character of the flow curves (their angle to shear stress axis) and viscosity change (Table 1) we can see, that while W/C ratio is increasing from 0.55 to 0.80, cement slurry viscosity at different shear rates is decreased about 3.2 times, and dilatancy changes are not significant.

GGBS cement slurry with different W/C ratios rheological curves are displayed in Fig. 3.

From the curves presented in Fig. 3 we can see that while W/C ratio is increasing, GGBS cement slurry yield stresses are decreased. According to the character of the flow curves (their angle to shear stress axis) and viscosity

change (Table 2) we can see, that while W/C ratio is increasing from 0.55 to 0.80, cement slurry viscosity at different shear rates is decreased about 4.9 times, and dilatancy changes are not significant.

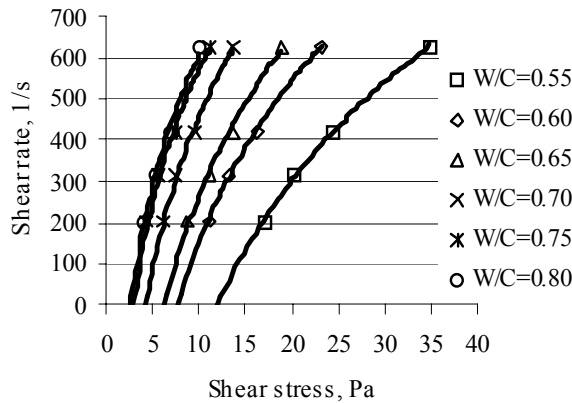

Fig. 2. Portland cement slurry with different W/C ratios shear rate dependency upon the shear stress

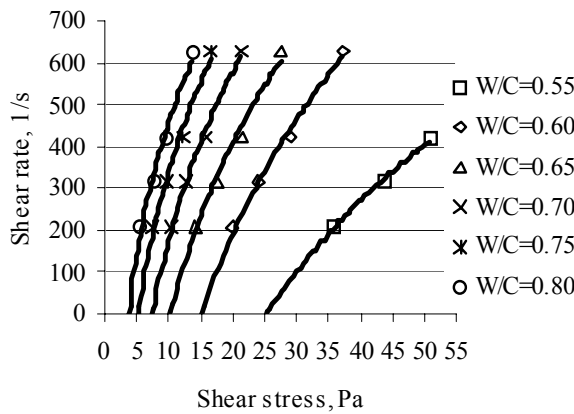

Fig. 3. GGBS cement slurry with different W/C ratios share rate dependency upon the shear stress

Portland cement and GGBS cement slurries yield stress dependency upon the cement concentration (calculated by equation (8)) is demonstrated in Fig. 4.

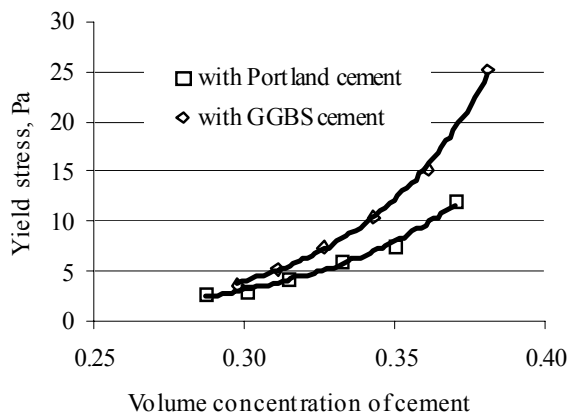

Fig. 4. Portland cement and GGBS cement slurry yield stress dependency upon the cement concentration

From the curves in Fig. 4 we can see, that while cement volume concentration changes from 0.28 to 0.39, the Portland cement slurry yield stress is increased 4.62 times and GGBS cement slurry – 6.8 times. GGBS cement

slurry has got greater (about 2 times) yield stresses in comparison with Portland cement slurry yield stresses. This fact is predestined by differences in cement particle shape an character of their surfaces.

Portland cement and GGBS cement slurry viscosity dependencies upon the cement concentration, when the shear rate is 205 1/s, are displayed in Fig. 5. As we can see in this figure, while the cement concentration is increasing from 0.28 to 0.39, the Portland cement slurry viscosity is increased 3.8 times and GGBS cement slurry – 5.8 times. When the cement concentration is low, the slurry viscosity differs not much, but when the cement concentration in the slurry is greater, the GGBS cement slurries viscosity increases about 2 times more than this of the slurry of Portland cement. This can be also explained by differences of cement particles shape and their surface characteristics. In slurry with irregular shape, edged particles of the ground granulated blast furnace slag cement some intrinsic friction appears, which increases the slurry viscosity.

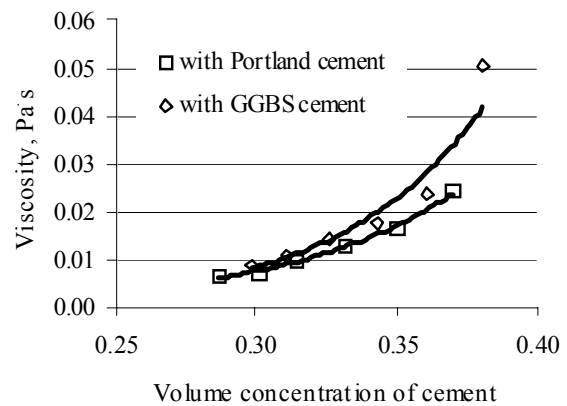

Fig. 5. Portland cement and GGBS cement slurries viscosity dependences upon the cement concentration, when the speed gradient is 205 1/s

In the range of cement volume concentration from 0.39 to 0.28 or W/C ratio from 0.55 to 0.80 yield stress and viscosity of GGBS cement slurry is about 1.8 times and 1.6 times respectively greater than Portland cement slurry. When in the slurry cement volume concentration is decreasing, distance among the cement particles is increasing and the system binding quality is decreased. Viscosity of such a dispersive system is approaching water viscosity (Tables 1 and 2).

Cement particles test using an electronic microscope demonstrated, that most of Portland cement particles edges are polished during the grinding, so a great part of these particles are close to cube or even sphere in there shape (Fig. 6, a and b). In GGBS cement it is quite easy to notice particles of granulated blast furnace slag, because most of them have sharp edges and angles, stick shape with a bit smaller and more round clinker particles (Fig. 6, c and d). Looking at those microphotographs we can see, that GGBS cement particles, in comparison with Portland cement particles, are not regular in their shape.

Even more, part of granulated blast furnace slag cement particles, which are characterized by a sharp edged prolonged shape, in their size obviously are outstanding in comparison with the surrounding smaller clinker particles. The average size of GGBS cement particles is about the

Table 1. Yield stress, viscosity and dilatancy factor of Portland cement slurries

No.	W/C	Viscosity, [Pa·s], at shear rates, [1/s]				τ_0 , [Pa]	D , [(Pa·s)/Pa]
		205	315	420	630		
1	0.55	0.0245	0.0256	0.0296	0.0363	12.00	0.0066
2	0.60	0.0167	0.0178	0.0206	0.0248	7.50	0.0066
3	0.65	0.0129	0.0153	0.0177	0.0201	6.10	0.0072
4	0.70	0.0094	0.0103	0.0129	0.0148	4.20	0.0073
5	0.75	0.0072	0.0089	0.0108	0.0127	2.90	0.0087
6	0.80	0.0065	0.0084	0.0105	0.0118	2.60	0.0087

Table 2. Yield stress, viscosity and dilatancy factor of GGBS cement slurries

No.	W/C	Viscosity, [Pa·s], at shear rates, [1/s]				τ_0 , [Pa]	D , [(Pa·s)/Pa]
		205	315	420	630		
1	0.55	0.0504	0.0591	0.0614	–	25.19	0.0071
2	0.60	0.0238	0.0286	0.0329	0.0350	15.19	0.0065
3	0.65	0.0176	0.0225	0.0267	0.0271	10.37	0.0070
4	0.70	0.0140	0.0174	0.0203	0.0218	7.41	0.0072
5	0.75	0.0110	0.0148	0.0168	0.0181	5.19	0.0077
6	0.80	0.0087	0.0133	0.0141	0.0160	3.70	0.0088

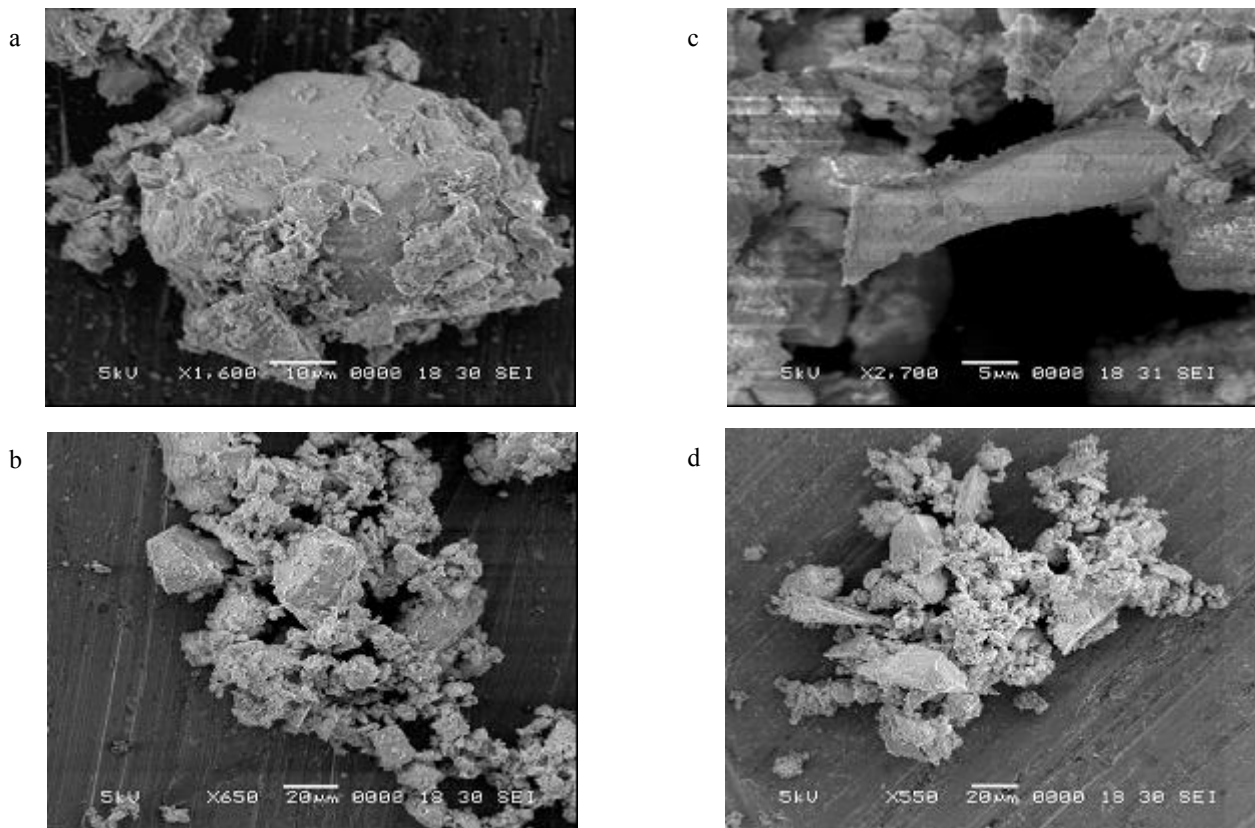

Fig. 6. Portland cement particles (a) and particle accumulations (b) microphotographs; GGBS cement particles (c) and particle accumulations (d) microphotographs

some as Portland cement particles. This was noticed after investigation of forty randomly appeared in the field of microscope watch, both GGBS cement and Portland cement particles (Table 3).

Table 3. Characteristics of particles of the Portland cement and GGBS cement

Characteristics	Portland cement	GGBS cement
Average of particle size, μm	20.9	19.8
Standard deviation of particles size, μm	13.5	12.4
Minimum value of particle size, μm	3.7	3.6
Maximum value of particle size, μm	56.2	57.1
Average value of L/D ratio	1.30	1.85
Minimum value of L/D ratio	1.0	1.0
Maximum value of L/D ratio	1.8	3.8

From the data presented in the Table 3 we can see, that the diameter of the tested particles does not differ much, the distribution of particles size is about the same for both cements, and their diameter maximum and minimum values are rather like. Ratio of the particles form L/D is calculated as a particle maximum to minimum

dimension ratio, and it shows that GGBS cement particles are more elongated, less close to a ball or a cube. For Portland cement average L/D ratio value is 1.30, and for GGBS cement is 1.85.

5. DISCUSSION

While changing cement concentration in the slurry, its viscosity was measured, and following the calculation results corresponding to the experimental values (Tables 4 and 5), the coefficients a_c and b_c to the (7) equation, were chosen. In calculation of the slurries theoretical viscosity the coefficient a_c , which evaluates the particles shape, was accepted as 2.7 for Portland cement (the Einstein coefficient for spherical shape particles is equal 2.5), and for GGBS cement – 2.9.

Coefficient b_c , which characterizes particle volume distribution density, is calculated using the equation (9). It was changed according to the cement volume concentration or it was supposed to be constant, though the cement volume concentration changes (Tables 4 and 5).

Portland cement slurry viscosity dependency on the cement concentration calculated and found out during the experiments is presented in Fig. 7, and this for GGBS cement is presented in Fig. 8.

From Figures 7 and 8 we can see, that good correlation was obtained using constant coefficient b_c (Fig. 7 and 8).

Table 4. Calculated and experimental rheological properties of Portland cement slurry

No.	W/C	Volume concentration of cement	Coefficient b_c		Yield stress, [Pa]		Viscosity, [Pa·s]		
			Calculated by (16) formula	Calculated by (9) formula	Calculated by (17) formula	By experimental results	With constant b_c	With changeable b_c	By experimental results
1	0.55	0.370	1.89	1.89	13.5	12.00	0.0270	0.0270	0.0245
2	0.60	0.350		2.00	8.0	7.50	0.0160	0.0226	0.0167
3	0.65	0.332		2.11	5.5	6.10	0.0109	0.0192	0.0129
4	0.70	0.315		2.22	4.1	4.20	0.0082	0.0166	0.0094
5	0.75	0.301		2.33	3.3	2.90	0.0065	0.0146	0.0072
6	0.80	0.287		2.43	2.7	2.60	0.0054	0.0129	0.0065

Table 5. Calculated and experimental rheological properties of GGBS cement slurry

No.	W/C	Volume concentration of cement	Coefficient b_c		Yield stress, [Pa]		Viscosity, [Pa·s]		
			Calculated by (16) formula	Calculated by (9) formula	Calculated by (17) formula	By experimental results	With constant b_c	With changeable b_c	By experimental results
1	0.55	0.381	1.89	1.89	24.95	25.19	0.0499	0.0499	0.0504
2	0.60	0.360		1.99	13.02	15.19	0.0260	0.0405	0.0238
3	0.65	0.342		2.10	8.18	10.37	0.0164	0.0336	0.0176
4	0.70	0.326		2.20	5.77	7.41	0.0115	0.0284	0.0140
5	0.75	0.311		2.31	4.40	5.19	0.0088	0.0243	0.0110
6	0.80	0.297		2.42	3.54	3.70	0.0071	0.0211	0.0087

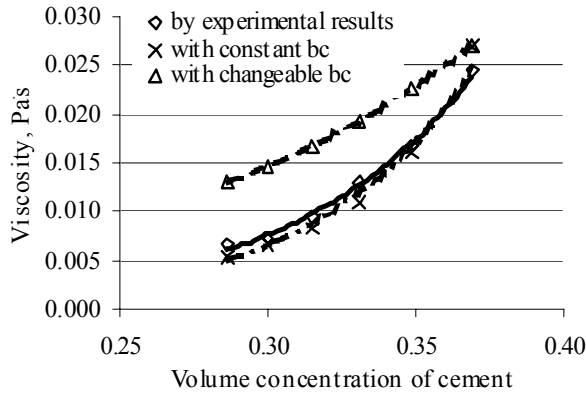

Fig. 7. Portland cement slurry calculated and found out during the experiment viscosities dependency on the cement concentration

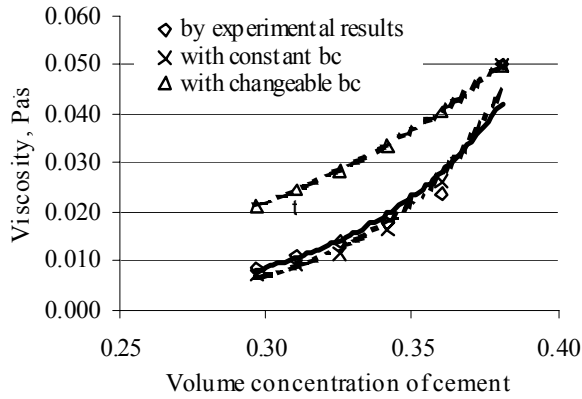

Fig. 8. GGBS cement slurry calculated and found out during the experiment dependency on the cement concentration

It means, that coefficient b_c does not depend on cement volume concentration in the slurry. It is suggested to calculate the coefficient b_c using this equation:

$$b_c = \frac{1}{\varphi_c^m k}, \quad (16)$$

where: coefficient k for Portland cement and GGBS cement it is equal 1.01...1.02.

We can account the coefficient b_c using the (16) equation, assuming that the maximum cement concentration in the slurry is equal to 1–2 % greater concentration that is in the normal consistency slurry. So, after making such an assumption and know water requirement for normal consistency cement slurry, it is easy to calculate the coefficient b_c value for different cements.

Particle shape coefficient a_c values, found out in the experiment, for Portland cement are 2.7, and for GGBS cement are 2.9. This coefficient value correlates with particle length to diameter ratio L/D . Coefficient a_c dependency on the particle length to diameter ratio L/D is presented in Fig. 9.

If some other cement is used in cement slurry, then according to the ratio L/D and dependency in Fig. 9 we can find the coefficient a_c , which is necessary for calculation of the cement slurries viscosity.

Portland cement and GGBS cement slurries with different W/C ratios dilatancy values are calculated according to the (15) formula and are presented in the

Tables 1 and 2. We can see that while cement volume concentration is changing from 0.29 to 0.38 for Portland cement and GGBS cement slurries their dilatancy does not change greatly.

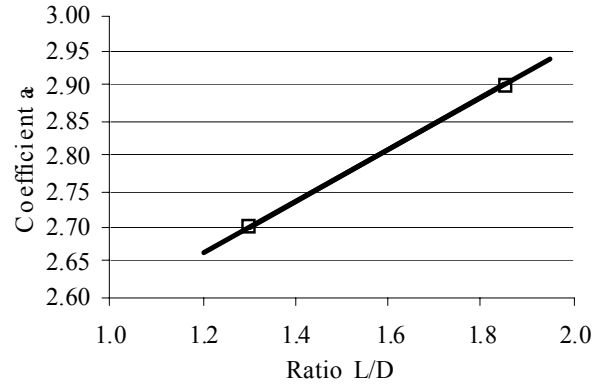

Fig. 9. Particles shape coefficient a_c dependency on the ratio L/D

The results presented in Fig. 4 demonstrate, that cement slurry yield stresses, as well as viscosity, while the particles volume concentration is increasing, are changing by an exponent dependency. That is why for prognosis of yield stresses it is possible to use a modified Mooney dependency, using the same coefficients a_c for the particles shape and b_c for the particles volume distribution density:

$$\tau_0 = 0.5 \cdot \exp \frac{a_c \varphi_c}{1 - b_c \varphi_c}, \quad [\text{Pa}] \quad (17)$$

Portland cement and GGBS cement slurry yield stresses, calculated according to the (17) equation and found out during the experiments are presented in the Tables 4 and 5. The calculated Portland cement slurry yield stresses and those found during the experiment results dependency on the cement concentration is presented in the Fig. 10, and for GGBS cement – in Fig. 11.

Looking at Fig. 10 and 11 we can see, that according to the (17) equation the calculated slurry yield stress values quite precisely correspond to the results of the experiment, so this dependency is suitable for prediction of slurry yield stresses.

Some references point out, that glassy state granulated blast furnace slag particles improve cement slurry (mortar, concrete mixture) rheological properties. Some others state, with adding some ground granulated blast furnace slag into cement, flow properties of slurries, mortars and concrete mixtures is improved. Properties of those mixtures depend on slag grinding method and on its fineness. Z. X. Zhang and J. Han [27] after testing very fine additives (granulated blast furnace slag, micro silica, ashes, limestone and other) effect on cement slurry rheological properties have found, that while increasing quantity of such additives, cement slurry yield stress most often are decreased. But slurry viscosity depends on the additives type and quantity. Very finely ground slag ($S = 846 \text{ m}^2/\text{kg}$) reduces slurry viscosity efficiently, when the additive is added by more than 15 % of cement mass.

M. Heikal, I. Aiad, I. M. Helmy [28] tested GGBS cements, prepared of ground granulated blast furnace slag and Portland cement clinker, taken in different proportion (70/30, 50/50 and 30/70 per cents) mixture properties. Into

those mixtures also there were added 2.5; 5.0; 7.5 and 10 % of cement dust. The test results showed, that after adding granulated blast furnace slag, the cement slurry viscosity decreases and in greater effect, if more slag is added.

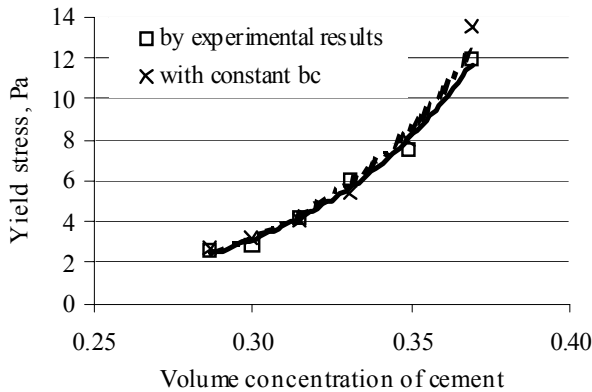

Fig. 10. Portland cement slurry calculated and found out during the experiment yield stress dependency on the cement concentration

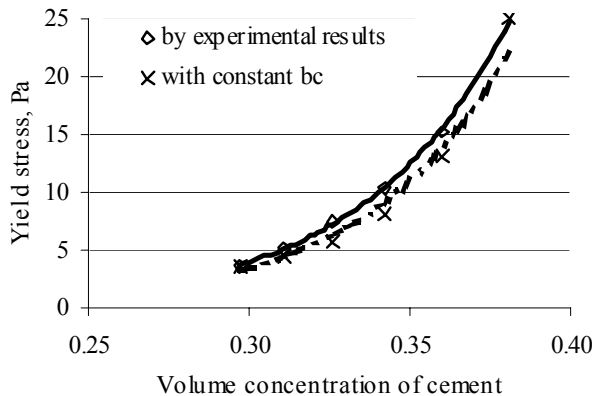

Fig. 11. GGBS cement slurry calculated and found out during the experiment yield stress dependency on the cement concentration

Great influence on GGBS cement slurry rheological properties has slag grinding technology. H. Wan, Z. Shui, Z. Lin [29] investigated granulated blast furnace slag granulometry and particles shape influence on cement properties. In this experiment slag was ground using a few methods: ball mill, air stream mill, laboratory vibrating mill and ball mill at the same time using some additive improving the grinding. Using slag morphology and granulometry there was a test where video electronic microscope and laser particle analyser were applied. Out of the test results we can see, that in the slag ground in air stream mill particle diameter is dispersed in a narrow interval, and when granulated slag was taken, after grinding it in a ball mill, the dispersion was in a large interval. Most of the particles gained of slag ground in vibrating mill have got a spherical shape and they are characterized by a smooth and plane surface. At the same time while grinding in ball and air stream mills, the particles are angulated and sharp edged. Slump of the mortars that were prepared using granulated blast furnace slag depended on the slag particles size dispersion, i.e. if

particle size of granulated slag was dispersed in a narrow interval, the mortars were characterized by greater slump.

Because of possible different slag grinding method and different particle size and shape characteristics results of experiments of various authors differ. On the other hand, that demonstrates that trying to describe in mathematical way GGBS cement slurry rheological properties, it is necessary to evaluate adequately such technological aspects as grinding method of granulated blast furnace slag particles, particles shape and status of their surface.

7. CONCLUSIONS

1. In the range of cement volume concentration from 0.39 to 0.28 or W/C ratio from 0.55 to 0.80 yield stress and viscosity of GGBS cement slurry is about 1.8 times and 1.6 times respectively greater than Portland cement slurry because of irregular and sharp edged shape of the slag particles.
2. For cement slurry viscosity prediction from cement volume concentration or W/C ratio exponential Mooney equation can be used.
3. Portland cement is predominated by particles of spherical shape, and GGBS cement particles are characterized by sharp edges and angles. Particle shape coefficient a_c in Mooney equation for predicting cement slurry viscosity for Portland cement can be taken as equal approximately 2.7, and for GGBS cement – 2.9.
4. Mooney equation coefficient of particles volume distribution b_c does not depend on cement volume concentration in cement slurry. This coefficient is related to cement particles volume concentration in normal consistency cement slurry or water requirement for normal consistency cement slurry.
5. For calculating cement slurry yield stresses a modified Mooney equation is suitable with the same coefficients a_c and b_c as in the viscosity equation.
6. Portland cement and GGBS cement slurries dilatancy does not change significantly when cement volume concentration changes from 0.28 to 0.39.

REFERENCES

1. **Tang, C.-W., Yen, T., Chang, C.-S., Chen, K.-H.** Optimizing Mixture Proportions for Flowable High-Performance Concrete via Rheology Tests *ACI Materials Journal* 98 (6) 2001: pp. 493 – 502.
2. **Hu, Ch., de Larrard, F.** The Rheology of High-Performance Concrete *Cement and Concrete Research* 26 (2) 1996: pp. 283 – 294.
3. **Banfill, P.F.G.** The Rheology of Fresh Cement and Concrete – a Review *11-th International Cement Chemistry Congress*. Durban, May 2003: pp. 136-149.
4. **Curcio, F., DeAngelis, B. A.** Dilatant Behavior of Superplasticized Cement Pastes Containing Metakaolin *Cement and Concrete Research* 28 (5) 1998: pp. 629 – 634.
5. **Skripkiūnas, G., Daukšys, M.** Investigation of Rheological Properties and Dilatancy of Cement Slurries *Conference on Concrete and Ferroconcrete Technologija*, Kaunas. 2003: p. 28 – 35 (in Lithuanian).

6. **Daukšys, M.** Influence of Cement Type on Rheological Properties of Cement Slurries *Advanced Materials and Technologies. Book of Abstracts of the 5-th International Summer School-Conference* Technologija, Kaunas, 2003: p. 31.
7. **Skripkiūnas, G., Daukšys, M.** Dilatancy of cement slurries with chemical admixtures *Journal of Civil Engineering and Management*. Technika, Vilnius. 10 (3), 2004: pp. 227-233.
8. **Skripkiūnas, G., Daukšys, M.** Influence of Chemical Admixtures on Rheological Properties and Dilatancy of Cement Slurries *Modern Building Materials, Structures and Techniques, Abstracts of the 8-th International Conference*. Vilnius, 2004: pp.75 – 76.
9. **Reiner, M.** Deformation, Strain and Flow. An Elementary Introduction to Rheology. Gostoptechizdat, Moscow. 1963: 381 p. (in Russian).
10. **Uryev, N. B., Michailov, N. V.** Rheological Properties of the Cement-Water Suspensions under Vibration *Proceedings of Academy of Science of USSR. Technical Physics* 153 (4) 1963: pp. 828 – 831 (in Russian).
11. **Saak, A. W., Jennings, H. M., Shah, S. P.** The Influence of Wall Slip on Yield Stress and Viscoelastic Measurements of Cement Paste *Cement and Concrete Research* 31 (2) 2001: pp. 205 – 212.
12. **Lapasin, R., Papo, A., Rajgelj, S.** Flow Behavior of Fresh Cement Pastes. A Comparison of Different Rheological Instruments and Techniques *Cement and Concrete Research* 13 (3) 1983: pp. 349 – 356.
13. **Ferraris, Ch. F., Martys, N. S.** Relating Fresh Concrete Viscosity Measurements from Different Rheometers *Journal of Research of the National Institute of Standards and Technology* 108 (3) 2003: pp. 229 – 234.
14. **Rahman, M. A., Nehdi, M.** Effect of Geometry, Gap and Surface Friction of Test Accessory on Measured Rheological Properties of Cement Paste *ACI Materials Journal* 100 (4) 2003: pp. 331 – 339.
15. **Khayat, K. H., Saric-Coric, M., Liotta, F.** Influence of Thixotropy on Stability Characteristics of Cement Grout and Concrete *ACI Materials Journal* 99 (3) 2002: pp. 234 – 241.
16. **Struble, L. J.** Rheology of Flocculates and Dispersed Cement Paste *Fundamentals of Refractory Castables, Thirtieth Annual Symposium on Refractories*. St. Louis, Missouri, March 25, 1994: 13 p.
17. **Asaga, K., Roy, D. M.** Rheological Properties of Cement Mixtures: IV. Effects of Superplasticizers on Viscosity and Yield Stress *Cement and Concrete Research* 10 (2) 1980: pp. 287 – 295.
18. **Discussion by Karam, G. and authors.** Viscosity Equation for Fresh Concrete. Paper by J. Murata and H. Kikukawa *ACI Materials Journal* 90 (2) 1993: pp. 194 – 195.
19. **Mansoutre, S., Colombet, P., Van Damme, H.** Water Retention and Granular Rheological Behavior of Fresh C₃S Paste as a Function of Concentration *Cement and Concrete Research* 29 (9) 1999: pp. 1441 – 1453.
20. **Afanasyav, A. A.** The Technology of the Impulse Compacting of the Concrete Mixtures. Stroyzdat, Moscow, 1987: 168 p. (in Russian).
21. **Gorchakov, G. I. and others.** Composition, Structure and Properties of the Cement Concrete. Stroyzdat, Moscow, 1976: 231 p. (in Russian).
22. **Bleschik, N. P.** Structural and Mechanical Properties and Rheology of the Concrete Mixtures and Vacuum Concrete. Nauka i Technika, Minsk, 1977: 232 p. (in Russian).
23. **Gumuliauskas, A.** A Question of the Evaluation of the Concrete Workability *Technology of the Concrete: Proceedings of Conference* Kaunas, 1989: pp. 13 – 17 (in Lithuanian).
24. **Gumuliauskas, A.** About Structural Basic of Design of the Concrete Mixtures *Technological Mechanics of the Concrete: Collected Scientific Works*. Riga, Latvia, 1990: pp. 85 – 93 (in Russian).
25. **Skripkiūnas, G.** Optimization of Concrete Macrostructure According to its Technological and Service Properties and Raw Materials Resources. *PhD Thesis*. Kaunas University of Technology, 1993: 185 p. (in Lithuanian).
26. **Huynh, L., Jenkins, P., Ralston, J.** The Rheological Properties of a Copper Concentrate Slurry: from Surface Chemistry to Pipeline Transport www.Rheofuture.de/papers2002/300702_au_01.pdf. 2002: 11 p.
27. **Zhang, X., Han, J.** The Effect of Ultra-Fine Admixture on the Rheological Property of Cement Paste *Cement and Concrete Research* 30 (5) 2000: pp. 827 – 830.
28. **Heikal, M., Aiad, I., Helmy, I. M.** Portland Cement Clinker, Granulated Slag and By-Pass Cement Dust Composites *Cement and Concrete Research* 32 (11) 2002: pp. 1805 – 1812.
29. **Wan, H., Shui, Z., Lin, Z.** Analysis of Geometric Characteristics of GGBS Particles and Their Influences on Cement Properties *Cement and Concrete Research* 34 (1) 2004: pp. 133 – 137.

DOI: 10.5755/j01.ms.11.2.26509