

Determination of Modulus of Elasticity in Hypoeutectic Silumin Castings

Mieczysław HAJKOWSKI*

Poznań University of Technology, Piotrowo 3, 60-138, Poland

Received 20 June 2005; accepted 08 July 2005

The paper presents the results of investigations of elasticity modulus of aluminum alloys castings of various silicon content. The castings solidified in various thermal conditions. It was found that modulus of elasticity depend on microstructure parameters. The results of studies for elasticity modulus were presented using different relationships. Computations were made for elasticity modulus of α -phase and eutectic determined in different conditions of solidification process. The results of calculated modulus of elasticity were compared with that taken from the experiment for castings solidify in various conditions.

Keywords: castings, Al-Si alloys, elasticity modulus.

1. INTRODUCTION

All materials undergo some deformation during their exploitation. One of the criteria of proper material choice is its ability to overcome the deformation. Material ability to resist the load in the range of elastic deformation, achieved in result of the casting process, is determined not only by the force of interatomic bonds but also by the defects in the structure of crystals, boundaries of the grains, and microporosity [1]. Macroelasticity of polycrystalline casted materials is an effect of microelasticity, grain anisotropy defects, difference between the properties of particular grains, and microporosity. In the castings made of hypoeutectic Al-Si an α -phase and Si+ α eutectic occur. Single crystals, for example of the α -phase, are characterized by anisotropic modulus of elasticity. In the (111) crystallographic direction the Young's modulus $E_{(111)} = 77.4$ GPa, while in the (100) direction $E_{(100)} = 64.1$ GPa [2]. In a polycrystalline material the modulus takes an intermediate value. The differentiation of the modulus in the crystal indicates that mutual orientation and the slope angle of the crystals with respect to the load direction should affect the value of the elasticity modulus.

The work is aimed at determining the dependence of modulus of elasticity of the castings solidifying in various thermal conditions on microstructure parameters and analysis of mathematical relationships found in literature with regard to their usefulness for purposes of forecasting the modulus of elasticity of the castings made of Al-Si alloys.

2. METHODS OF THE STUDY

Moduli of elasticity (in lengthwise and transversal directions) were investigated in the castings made of Al alloys of varying silicon contents: 0.4 % Si (the contents approximating the one of the α -phase, in the castings of $\varnothing 30$ mm, solidifying in the moulds of quartz sand), 6.7 % Si and 12.5 % Si (eutectic contents), solidifying in various thermal conditions (the moulds: Kw, Ch, Mi-Cu, St). The mould markings: Kw, Ch, Mi – the sands with

liquid glass binder on the quartz sand, chromite sand, or microspheres (insulation material) respectively. Cu is a chill in the microsphere mould. The St mould is made of steel, with the cast reproducing surface covered with graphite. The castings are made in a 6-cavity mould of the design shown in Fig. 1. Dried moulds were poured with a refined alloy (the refiners of trade names "degasal T200" and "probat fluuss Al224") of the temperature 720 ± 3 °C.

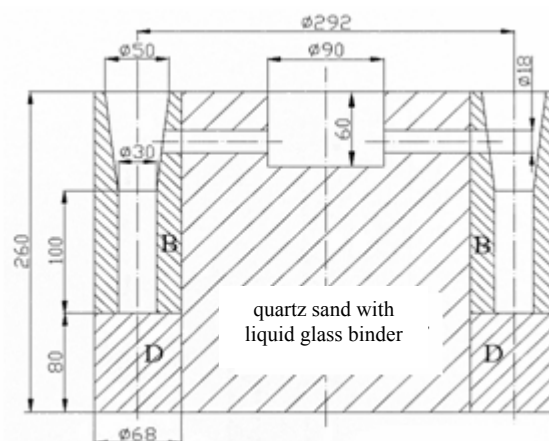

Fig. 1. Experimental mould, B – material: quartz sand (Kw), chromite sand (Ch), microsphere sand (Mi), steel (St), D – material: quartz sand (Kw), chromite sand (Ch), copper (Cu), steel (St)

The microstructure parameters were examined on lengthwise and transversal polished specimens. An average thickness of dendrite branches of the α -phase (d_α), thickness (g_1) and the length (l_1) of Si precipitation in the eutectic, average angle of the dendrite slope with respect to the cylinder axis, and the degree of mutual orientation of dendrites were determined.

Elasticity modulus were investigated on the samples of measurement diameter and length equal to 14 mm (the centre of measurement length located 35 mm from the bottom cylinder base).

3. RESULTS OF STUDIES, CALCULATION AND ANALYSIS

Results of studies on the effect of solidification conditions on modulus of elasticity of the castings of

* Corresponding author. Tel.: +48-61-6652459; fax: +48-61-6652217
E-mail address: mieczyslaw.hajkowski@put.poznan.pl (M. Hajkowski)

various silicon contents are shown in Fig. 2. The microstructure is illustrated in Fig. 3 for the castings made in a uniform mould – Kw and in the mould with a chill – Mi-Cu (the mould of improved heat carrying away in the cylinder axis direction).

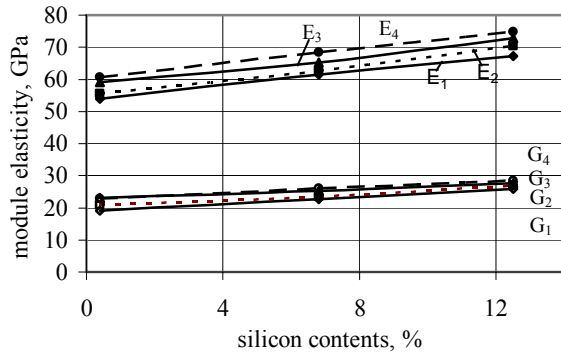

Fig. 2. Dependence of Young's modulus E and shear modulus G on alloy silicon contents in solidifying castings in the moulds: 1 – Kw; 2 – Ch; 3 – Mi-Cu; 4 – St

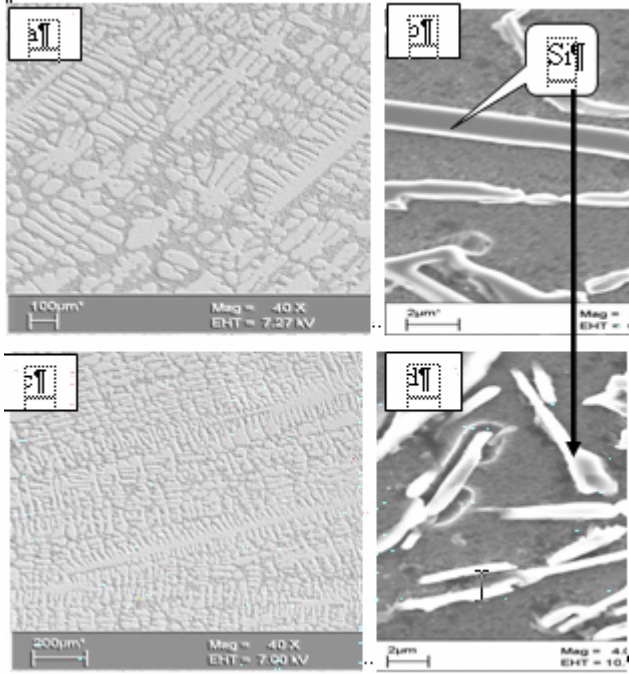

Fig. 3. Microstructure of dendrites of the α -phase: a – Kw, c – Mi-Cu; eutectic Si+ α : b – Kw, d – Mi-Cu

Microstructure parameters: average thickness of dendrite branches (d_α) and Si precipitations in eutectic (g_1) of the castings solidifying in the Kw mould are more than twice larger as compared to the ones solidifying in Mi-Cu moulds, with the degree of mutual dendrite orientation (Z_α) being about 4 times larger.

Results of analysis of significance (with multi-regression method) of the effect of investigated parameters of the structure on modules of elasticity of the castings of partially oriented structure of the AlSi6.7 alloy (0.019 % Fe) made under various thermal conditions are presented in Table 1. The results indicate that parameters of the structure not connected directly to the dimensions of crystallites (β_α and Z_α) also significantly affect elasticity modulus of the castings. The studies give evidence that the

Young modulus depends on bigger number of parameters of the crystalline structure than the shear modulus does.

Table 1. Parameters of crystalline structure of the AlSi6.8 alloy castings solidifying under various thermal conditions (the moulds Kw, Mi-Och, Ch, St) significantly affecting the elasticity constants

Elasticity constants	Parameters of the crystalline structure
Young's modulus E	$d_\alpha, Z_\alpha, \beta_\alpha, g_1$
Shear modulus G	d_α, Z_α

In order to verify whether the modulus of elasticity may be determined by a single parameter of the structure the Table 2 provides a correlation coefficient (R). Analysis of significance of influence of the parameters of structure and correlation coefficients indicates that the relationship between the modulus of elasticity and structure of the casting made of the examined alloy may be defined by a single parameter of crystalline structure, i.e. the average thickness of dendrite branch of the α -phase d_α (Table 1, $R = -0.96$ and -0.97).

Table 2. Correlation coefficients of Young's modulus and shear modulus with a single parameter of crystalline structure of the AlSi6.8 (0.019 % Fe) alloy castings solidifying under various thermal conditions

Elasticity constants	Parameters of the crystalline structure				
	d_α	β_α	Z_α	g_1	I_1
	correlation coefficients with a single structural parameter				
Young's modulus E	-0.95	-0.51	0.39	-0.92	-0.93
Shear modulus G	-0.96	-0.42	0.32	-0.93	-0.92

The relationship between the moduli of elasticity and significant parameters of the structure for the castings of solidifying module similar to the one used in the work ($M_k = 7.5$ mm) of the AlSi6.8 (0.019 % Fe) alloy castings solidifying under various conditions occurring in casting moulds is as follows (the parameters occurring in the equations are ordered starting from the most significant one):

– Young's modulus

$$E = 39421.6 Z_\alpha - 1151.3 d_\alpha + 31496.7 g_1 + 748.2 \beta_\alpha \quad (1)$$

– shear modulus

$$G = 1506.1 Z_\alpha - 452.4 d_\alpha, \quad R = 0.97 \quad (2)$$

Consideration of the experimental data on modulus of elasticity of hypoeutectic α -phase (AlSi0.4) and eutectic (AlSi12.5) included in the castings obtained under various solidification conditions allows to calculate the modules of elasticity by means of additive equations (of the mixtures), i.e. so-called Voigt and Reuss model [3]:

– for equal deformations of α -phase and eutectic (upper value of the modulus):

$$E_{//} = E_\alpha (1 - u_e) + E_e \cdot u_e; \quad (3)$$

– for equal stress of α -phase and eutectic (lower value of the modulus):

$$E_{\perp} = (E_{\alpha} \cdot E_e) / [E_{\alpha} \cdot u_e + E_e(1 - u_e)] ; \quad (4)$$

and, based on the constitutive equation:

$$\sigma_{ij} = C_{ijkl} \cdot \varepsilon_{kl} , \quad (5)$$

where α, e is α -phase or eutectic, respectively, u_e is the contribution of eutectic, C_{ijkl} is the elasticity tensor, $\varepsilon_{11}, \dots, \varepsilon_{13}$ is the strain tensor.

The calculation was aimed at verifying whether this method allows to determine, with a good accuracy, the modulus of elasticity of a casting made of an Al-Si alloy of partially oriented structure. First of all, the calculation was performed with the method of mixtures, with the help of the equation (3). Moduli of elasticity obtained from an experiment for the α -phase and eutectic of the castings solidifying with various values of intensity of heat carrying away to the mould are shown in Table 3. The equation (3) determines the upper values of the modulus of elasticity (crystallites of parallel orientation with respect to the tension direction), while the equation (4) (crystallites of perpendicular orientation with respect to the tension direction) provides their lower values.

Table 3. Values of moduli of elasticity: experimental for the alloy phases and calculated with the method of mixtures (marked with a z-index) for the AlSi6.8 alloy castings

Solidification conditions (mould)	Experimental modules for the phases				
	α -phase			eutectic	
	$E, \text{ GPa}$	$G, \text{ GPa}$	Z_{α}	$E, \text{ GPa}$	$G_p, \text{ GPa}$
Kw	54.9	20.2	0.28	67.8	26.1
Ch	56.3	20.9	0.25	70.4	26.9
Mi-Cu	59.2	22.1	0.81	72.6	27.7
St	60.7	22.9	0.21	74.8	28.5
	AlSi6.8 alloy modules				
	calculated (z)			experimental	
	$E, \text{ GPa}$	$G, \text{ GPa}$	Z_{α}	$E, \text{ GPa}$	$G_p, \text{ GPa}$
Kw	60.7	22.7	–	60.8	23.2
Ch	62.5	23.5	–	62.7	23.9
Mi-Cu	65.5	24.7	–	67.7	25.4
St	67.1	25.4	–	68.4	26.1

Moreover, Young modulus of elasticity was calculated from the constitutive stress-strain relationship describing an anisotropic material of hexagonal symmetry, for the case of model structure is shown in Fig. 4.

Modulus of elasticity of the material of partially oriented crystalline structure should take the values between these levels. Therefore, further calculation of modules of elasticity was performed taking into account the relationship of mutual orientation of α -phase dendrites:

$$E_z = E_{\parallel c} Z_{\alpha} + E_{\perp c} (1 - Z_{\alpha}) ; \quad (6)$$

$$G_z = G_{\parallel c} Z_{\alpha} + G_{\perp c} (1 - Z_{\alpha}) , \quad (7)$$

where $E_{\parallel c}, E_{\perp c}, G_{\parallel c}, G_{\perp c}$ are the moduli of elasticity calculated from the formulus (3) and (4) based on the modulus of elasticity of the α -phase and eutectic found for predetermined solidification conditions.

The elasticity moduli calculated for the AlSi6.8 alloy castings (E_z and G_z) based on proposed equations (6) and (7) as well as experimental data are shown in Tables 3 and

4 (eutectic contribution to the casting structure was found in transversally polished specimens $u_e = 0.48$).

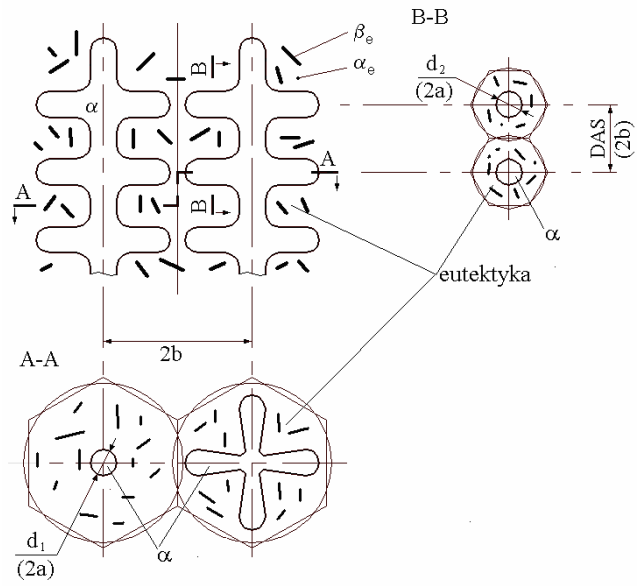

Fig. 4. Model of crystalline structure of a hypoeutectic Al-Si alloy casting

In case of hexagonal arrangement of the structure phases the elastic tensor C_{ijkl} (equation 5) has five independent variables ($C_{1111}, C_{1122}, C_{1133}, C_{3333}, C_{3131}$). Appropriate constitutive stress-strain relationships are derived in the paper [4]. They have the following form:

$$\sigma_{11} = C_{1111} \varepsilon_{11} + C_{1122} \varepsilon_{22} + C_{1133} \varepsilon_{33} \quad (8)$$

$$\sigma_{22} = C_{1122} \varepsilon_{11} + C_{1111} \varepsilon_{22} + C_{1133} \varepsilon_{33} \quad (9)$$

$$\sigma_{33} = C_{1133} (\varepsilon_{11} + \varepsilon_{22}) + C_{3333} \varepsilon_{33} \quad (10)$$

$$\sigma_{23} = 2C_{3131} \varepsilon_{23} \quad (11)$$

$$\sigma_{31} = 2C_{3131} \varepsilon_{31} \quad (12)$$

$$\sigma_{12} = (C_{1111} - C_{1122}) \cdot \varepsilon_{12} \quad (13)$$

Young's modulus of elasticity for tension along the cylinder axis of the model structure (Fig. 4) is given by the formula [4]:

$$E_K = \frac{C_{3333} \cdot (C_{1111} + C_{1122}) - 2C_{1133}^2}{(C_{1111} + C_{1122})} , \quad (14)$$

where

$$C_{1111} + C_{1122} = - \left[\frac{2(1-u_e)\mu_e(\lambda_{\alpha} + \mu_{\alpha} - \lambda_e - \mu_e) + 2A}{(1-u_e)(\lambda_{\alpha} + \mu_{\alpha} - \lambda_e - \mu_e) - (\lambda_{\alpha} + \mu_{\alpha} + \mu_e)} \right]$$

$$C_{1133} = \frac{(1-u_e)[2\lambda_{\alpha}\mu_e - \lambda_e(\mu_{\alpha} + \mu_e)] + \lambda_e(\lambda_{\alpha} + \mu_{\alpha} + \mu_e)}{(\lambda_{\alpha} + \mu_{\alpha} + \mu_e) - (1-u_e)(\lambda_{\alpha} - \lambda_e + \mu_{\alpha} + \mu_e)}$$

$$C_{3333} = \frac{\lambda_{\alpha} + \mu_{\alpha} + \mu_e(\lambda_e + 2\mu_e) - (1-u_e)^2(\mu_{\alpha} - \mu_e)B}{(\lambda_{\alpha} + \mu_{\alpha} + \mu_e) - (1-u_e)(\lambda_{\alpha} - \lambda_e + \mu_{\alpha} - \mu_e)} + \frac{(1-u_e)(\mu_{\alpha} - \mu_e)(3\lambda_e + 2(\mu_{\alpha} - \lambda_e))}{(\lambda_{\alpha} + \mu_{\alpha} + \mu_e) - (1-u_e)(\lambda_{\alpha} - \lambda_e + \mu_{\alpha} - \mu_e)}$$

$A = (\lambda_e + \mu_e)(\lambda_\alpha + \mu_\alpha + \mu_e)$; $B = (3\lambda_\alpha - 3\lambda_e + 2(\mu_\alpha - \mu_e))$, where $u_e = 1 - (a/b)^2$ is the eutectic surface fraction, $\mu = G = E/[2(1 + \nu)]$, $\lambda = \nu \cdot E/(1 + \nu)(1 - 2\nu)$ is the Lamé constant, (α - phase α , e - eutectic), $\nu = [(E/2G) - 1]$ is the Poisson ratio.

The data obtained from the experiment and calculated from the formulas, used for purposes of calculation of Young's modulus by means of the constitutive equation, together with the moduli obtained this way, are shown in Table 4.

Table 4. Values of Young's modulus (E_K) of the AlSi6,8 alloy castings calculated from the constitutive equation.

Solidification conditions (mould)	Lame constant, GPa			
	α -phase		eutectic	
	μ_α	λ_α	μ_e	λ_e
Kw	20.2	43.6	26.1	39.2
Ch	20.9	46.1	26.9	43.8
Mi-Cu	22.1	46.9	27.7	45.2
St	22.9	40.9	28.5	46.6
	Modules of elasticity, GPa			
	$C_{1111}+C_{1122}$	C_{3333}	C_{1133}	E_K
Kw	133.3	91.1	44.7	61.4
Ch	138.2	92.5	45.0	63.2
Mi-Cu	141.7	95.7	46.1	65.7
St	137.8	94.7	43.5	67.2

Comparison of Young's modulus calculated with the method of mixtures by means of the equation (3), the proposed equation (6), and the constitutive equation (14) with the experimental modules of Table 5 shows that the equations well describe the Young's moduli (considering the contribution of surface phases of the structure and elasticity modules of α -phase and eutectic for predetermined solidification conditions).

Table 5. Specification of Young's elasticity modulus of AlSi6,8 (0.019 % Fe) alloy castings, calculated from various equations and experimental data

Solidification conditions	Young's modulus of elasticity of the alloy, GPa				Poisson ratio of the alloy phases		
	calculated from the equation			experimental	α -phase	eutectic	
	E_{II}	E_Z	E_K				
Kw	61.0	60.7	61.4	60.8	0.34	0.30	
Ch	63.1	62.5	63.2	62.7	0.34	0.31	
Mi-Cu	65.6	65.5	65.7	67.7	0.34	0.31	
St	67.5	67.1	67.2	68.4	0.32	0.31	
Hypothetical	H1	111	-	93.9	-	0.34	0.37
	H2	111	-	101.0	-	0.34	0.34
	H3	111	-	109.4	-	0.34	0.31
H1: $E_\alpha = 56.3$ GPa, $G_\alpha = 20.9$ GPa, $E_e = 170$ GPa, $G_e = 62.0$ GPa, H2: $E_\alpha = 56.3$ GPa, $G_\alpha = 20.9$ GPa, $E_e = 170$ GPa, $G_e = 63.4$ GPa, H3: $E_\alpha = 56.3$ GPa, $G_\alpha = 20.9$ GPa, $E_e = 170$ GPa, $G_e = 64.9$ GPa							

The simulation performed for actual and hypothetical values of elasticity moduli (Young's and shear modules) of the α -phase and eutectic has shown that the Young modulus obtained for the alloy with the method of mixtures (equation 3) and the constitutive equation (14) approximate each other when $(\nu_\alpha/\nu_e) > 1.032$ (where: ν_α , ν_e - Poisson ratios of the α -phase and eutectic, respectively). On the other hand, Young's modulus calculated for the alloy (Table 5) with the use of the constitutive equation for $(\nu_\alpha/\nu_e) = 1$ is by 9 % smaller as compared to the one calculated with the method of mixtures (3), while for $(\nu_\alpha/\nu_e) = 0.92$ is even by 15 % smaller.

The equation of mixtures (3) gives proper results for the modulus of elasticity for the upper elastic limit E_{II} and with the use of the elasticity modulus of the α -phase and eutectic defined for predetermined solidification conditions. The use of a complicated constitutive relationship is then not required. Moreover, application of (6) and (7) formulas, including the degree of mutual orientation of α -phase dendrites is also useless. The formulas (6) and (7) may be used when only the value of Z_α varies, with the phases (d_α , g_1) remaining nearly constant.

4. CONCLUSIONS

1. Moduli of elasticity of the Al-Si alloy castings depend on several geometric parameters of their microstructure (dendrite branch thickness, the degree of mutual orientation, the angle of slope of the α -phase dendrites with respect to the load direction, and the thickness of Si-precipitation in the eutectic).

2. The values of modulus of elasticity of hypoeutectic Al-Si alloys of partially oriented structure may be calculated with the method of mixtures (3) based on the moduli of elasticity of the α -phase and eutectic under similar solidification conditions. Calculation results well approximate the experimental data.

REFERENCES

- Dong, M. J., Prioul, C., Francois, D. Damage Effect on the Fracture Toughness of Modular Cast Iron: Damage Characterization and Plastic Flow Stress Modeling *Metallurgical and Materials Transactions* 28A 1997: pp. 2245 - 2254.
- Bernsztejn, M. L., Zajmowski, W. A. Structure and Mechanical Properties of Metals. Warsaw, WNT, 1973 (in Polish).
- Wyrzykowski, J. W., Pleszak, E., Sieniawski, J. Deformation and Tearing of Metals. Warsaw, WNT, 1999 (in Polish).
- Hajkowski, M., Ignaszak, Z., Kamiński, H., Sypniewska-Kamińska, G. Modeling of Relation between Elasticity and Structure of Al-Si Hypoeutectic Alloys *Materials Science (Medziagotyra)* 6 (2) 1999: pp. 11 - 14.

DOI: 10.5755/j02.ms.26546