

Mechanical Reclamation Treatment of Used Silica Foundry Sand at Extra-low and Ambient Temperatures

Jozef DANKO*, Rafal DANKO

Department of Foundry Machines and Equipment, Foundry Engineering Faculty, AGH-University of Science and Technology, 30-059 Kraków, ul. Reymonta 23, Poland

Received 13 June 2005; accepted 11 July 2005

The article presents a short study of the mechanical reclamation techniques implemented in industry and of a research conducted at AGH-UST aiming at intensification and improvement of the mechanical reclamation processes by using extra-low temperature environment. In the paper, the laboratory stand and the results of mechanical reclamation of used foundry silica sands with bentonite and water glass binder, carried out at both extra-low (about minus 70 °C) and ambient temperatures, are presented. The obtained results were evaluated and compared with data taken from the foundry practice.

Keywords: foundry used sand, mechanical reclamation, cryogenic reclamation, sand testing, waste minimization.

1. INTRODUCTION

The reclamation of used moulding sands regarded as a mean of recycling own foundry waste originating from the process of making castings is a problem of primary importance for every foundry plant and equally for the protection of natural environment. Numerous publications stress the fact that dumping of the waste moulding sands or using them in unprocessed condition in road building or as a filler for dormant mines, etc. may have very serious implications for ecological safety of the environment. This is related, first of all, with possible penetration of toxic compounds included in the sand composition to the soil and underground water [1]. Very strict laws applied in the United States and in other countries of the western world [2] in the matter of foundry waste disposal to the dumping grounds clearly show us that this problem has been finally noticed and is now treated very seriously.

Within the research described in this paper some tests have been made to improve the effectiveness of a mechanical reclamation process as applied to the two types of the waste moulding sands typically produced during castings manufacture, namely:

- the sand with bentonite,
- the sand with water glass hardened with an addition of ethylene glycol (flodur).

The choice of the above mentioned sands for the tests and research was dictated by very practical reasons – they are both used on a very wide scale by domestic foundries, and both are known to be hardly reclaimable by the conventionally used methods [3, 4]. As we all know, a typical waste bentonite sand has been until recently considered absolutely harmless, and as such it was used quite willingly as a backfill material on the dumping grounds of municipal waste. However, the studies conducted recently by J. L. Lewandowski and others [5] have proved that this sand contains a very high level of

polycyclic aromatic hydrocarbons (PAHs), which are formed as a result of the molten metal acting on the carrier of lustrous carbon, which is one of the components of these sands.

The second type of the waste moulding sand accepted for studies, that is, the water glass sand from a floster process, is commonly considered to be the sand almost unreclaimable by any of the currently available types of the mechanical reclamation, which considerably reduces its application in spite of relatively low price and rather mildly negative impact on the environment. The most effective method of reclamation of these sands is a wet process, at present totally abandoned in Poland because of its strenuousness and very high cost. So, these sands are now reclaimed only by the mechanical process in an equipment which produces the effect of abrasion, rubbing and crushing. Yet, the low output of the mechanical reclamation applied to the waste moulding sands with water glass is the very reason why new techniques are searched to intensify and improve this process.

In own investigations described further in this text, it was thought to use extra-low temperatures as a factor intensifying the process of the waste sand mechanical reclamation. It was assumed that by considerably reducing the temperature at which the process of reclamation is carried out, the envelope of water glass, present on the surface of the sand grains, should become more brittle, and in the case of bentonite sands, the binding forces which are acting between the sand grains and the envelope of binder present on these grains should be weakened [6, 7]. This should improve the sand reclaimability in the case of both tested types of the waste sand and release in quite an easy manner the sand grains from the sticking envelope of the used binding material.

2. TESTS AND EXPERIMENTS

2.1. Laboratory stand

The laboratory test stand (Fig. 1) is a reduced model of the mechanical reclamation unit with blades acting as a

*Corresponding author. Tel.: +48-12-6172726; fax.: +48-12-6336348.
E-mail address: jd@agh.edu.pl (J. Dańko)

rotating abrasive element. The test reclamation unit enables the reclamation process to be carried out with and without the use of a cooling agent. It has been provided with a feeding system for liquid nitrogen to carry out the reclamation process at extra-low (cryogenic) temperatures.

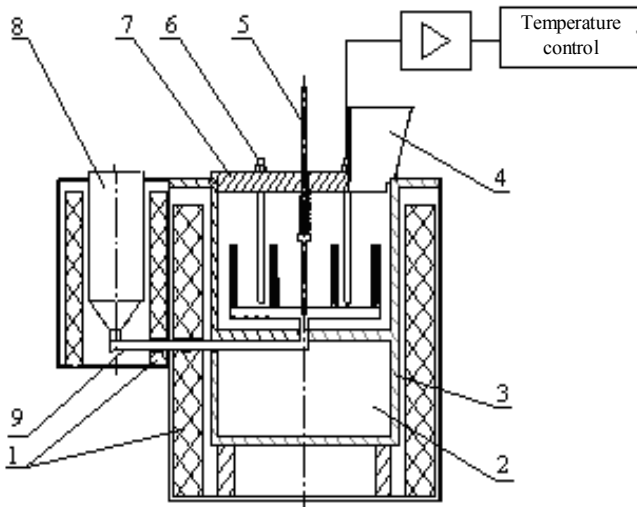

Fig. 1. Schematic of the experimental mechanical and combined (mechanical-cryogenic) reclamation unit 1 – housing with heat insulation, 2 – hollow volume, 3 – reclamation chamber, 4 – used sand feeder, 5 – impeller of abrasive aggregate, 6 – impact elements, 7 – cover plate, 8 – cryogenic agent container, 9 – cryogenic agent feeder [8, 9]

A temperature sensor, placed on the bottom of the sand container, enables current control of the temperature of the reclaimed waste sand.

The possibility of conducting in the same equipment either the mechanical reclamation alone, or a combination of the mechanical and cryogenic reclamation provides an excellent tool for comparison of the real efficiency of the reclamation process obtained in both examined cases.

2.2. The test run

The waste sand supplied from a foundry shop after separation of tramp metal and preliminary crushing and screening through a 3 mm mesh screen was subjected to de-dusting in a pneumatic classifier to remove the free dust fractions having an adverse effect on the process of reclamation. The process of the proper reclamation of the sand grains was conducted under the following operating parameters of the reclamation unit: rotational speed of the impeller blades – 300 rev/min, time of reclamation – 1, 3, 5, 10 and 15 min, successively. A sample of the waste sand (circa 4 kg) was subjected to reclamation at ambient temperature; the second analogical sample was reclaimed with simultaneous feeding of liquid nitrogen to the sand in an amount enabling the temperature of the reclaimed batch to be reduced to about minus 70 °C.

The effectiveness of releasing the sand grains from the envelope of the used binding material was evaluated by means of the tests mentioned in Table 1 which, as a result of own studies carried out previously [8, 9], were considered

to be the tools reliable enough in evaluating the degree of the examined waste sand reclamation.

Table 1. Parameters used in evaluation of the sand reclamation degree

Examined parameter	Waste sand with water glass	Waste sand with bentonite
Content of Na ₂ O in reclaim	X	
Clay binder content in reclaim		X
Value of pH and of ADV coefficient of the reclaim	X	X
Screen analysis after reclamation	X	X
Screen analysis after reclamation and final classification	X	X
Strength of the sand prepared with reclaim	X	X
Permeability of the sand prepared with reclaim		X

2.3. The results of the tests

The results of the tests are shown in Figures 2 – 5 and in Table 2.

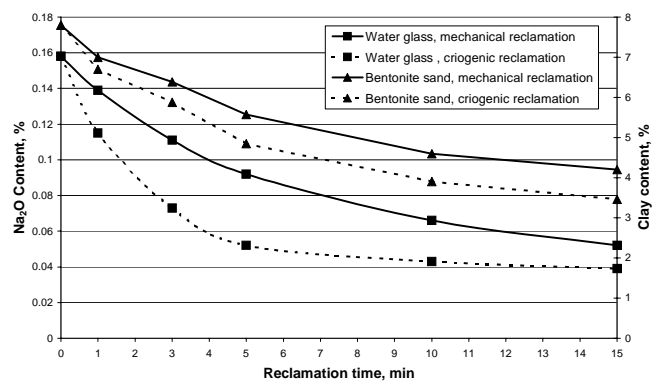

Fig. 2. Na₂O content (water glass used sand) and clay content (used bentonite sand) versus reclamation time

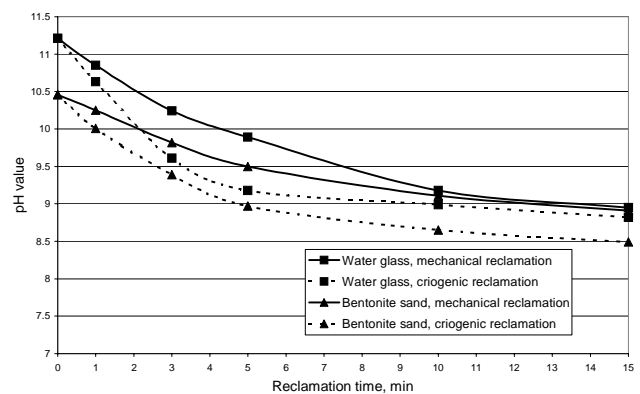

Fig. 3. The pH value versus reclamation time for reclaimed used sands

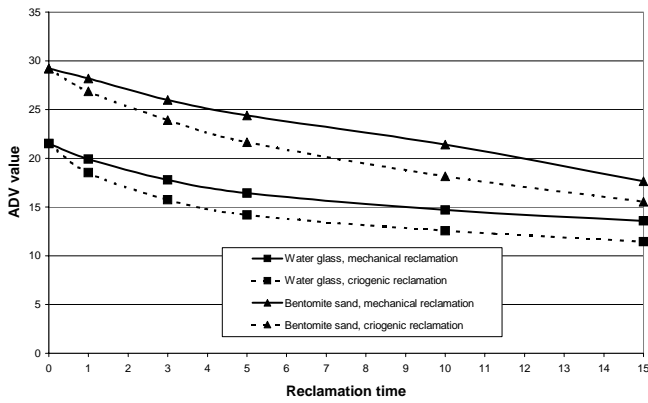

Fig. 4. ADV value versus reclamation time for reclaimed used sands

Table 2. Bending strength (R_g^u) of foundry mass prepared from reclaimed water glass sand after various reclamation time and 1, 4 and 24 h of hardening time

Moulding sand prepared from:	R_g^u 1 h, MPa	R_g^u 4 h, MPa	R_g^u 24 h, MPa
New sand	0.50	1.55	3.23
Used sand	0.0	0.34	0.93
Mechanical reclamation (MR)			
MR 1 min	0.10	0.52	1.19
MR 5 min	0.25	1.10	2.42
MR 10 min	0.38	1.51	3.25
MR 15 min	0.32	1.25	2.61
Cryogenic reclamation (CR)			
CR 1 min	0.25	1.03	2.18
CR 5 min	0.42	1.50	3.25
CR 10 min	0.40	1.26	3.01
CR 15 min	0.32	1.07	2.45

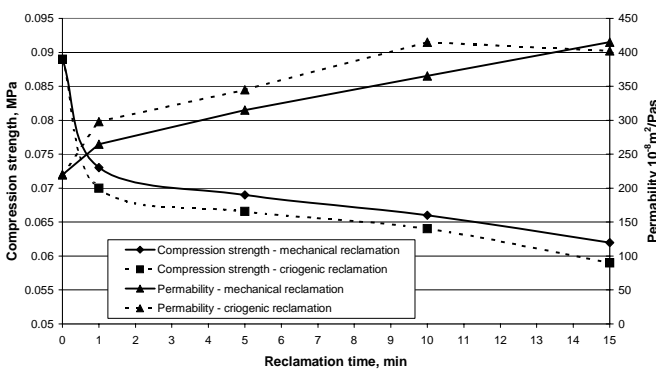

Fig. 5. Pressure strength and permeability of foundry mass prepared from reclaimed bentonite sands

2.3. Analysis of the results

The data shown in Figure 1 indicate that prolonged time of reclamation of the waste moulding sand with water glass results in reduced content of Na_2O in the reclaim. Reclamation at cryogenic temperatures reduces even more the value of this parameter, which is particularly well

visible at an initial stage of the reclamation process. In a comparable, for both cases, time of the reclamation, much better results of releasing the sand grains from the waste binder are obtained in the case of a high-rate cooling of the sand.

As we all know, the waste sand with water glass is characterised by a strong basic reaction – the feature that is to a great extent transposed to the reclaim obtained from this sand. The data shown in Figures 2 and 3 indicate that the values of the examined pH and ADV are much more advantageous in the case of mechanical-cryogenic reclamation. These values are observed to decrease along with an increasing degree of the sand grains cleaning and removal of binder envelope from their surface. Table 2 shows the results of mechanical tests which lead to a very obvious conclusion that in the mechanical-cryogenic reclamation the best results are obtained after 3 and 5 minutes of the conducted reclamation process. Although longer time of the reclamation process improves the degree of the sand grains cleaning, one can also note a negative effect of the prolonged reclamation, which is quick wear of the sand grains. The extra-cool sand grains are much more sensitive to mechanical degradation, their specific surface increases (as proved by the screen analysis), which means that the amount of binder necessary to keep constant the required thickness of the binder coating in sand mixture prepared with the reclaim must be increased as well.

In evaluating the effectiveness of a reclamation process of the waste sand with bentonite, as a main indication of the effectiveness of this reclamation has been adopted the content of the clay binder present in reclaim. The waste sand without any reclamation treatment, subjected only to removal of tramp metal, preliminary crushing, and screening through a 3 mm mesh screen is characterised by the clay binder content amounting to about 8 % (in present investigations it was 7.8 %). In foundries, this sand is rebonded with an addition of about 0.8 % bentonite and 0.1 % coal dust, and next – after having been mixed – it is used for production of moulds for castings. Typically, in a standard system, when the thermal load in a moulding sand, determined by an average mould weight/casting weight ratio, is assuming a value of 4 : 1, about 15 % of the unit sand should be subjected to reclamation after each cycle of the sand preparation [10, 11]. After reclamation treatment, the content of the clay binder in the sand drops to a value of 4.20 % and 3.5 % for, respectively, the mechanical and mechanical-cryogenic reclamation conducted for a time of 15 minutes. The chemical analysis of reclaim also indicates a high degree of removal of the used binder from the sand grains; in the case of mechanical-cryogenic reclamation this effect is even more pronounced. Figure 5 shows the results of testing the mechanical strength and permeability of sands prepared with the obtained reclaims. In these studies the obtained reclaim was treated as a replacement of the new sand. The sand composition included 7 % of Zębiec bentonite and 3.5 % of water content. In the case of the sand with bentonite, raising the intensity of reclamation makes the value of the compression strength R_c^w decrease due to removal from the sand grains surface of a portion of the still active binder. The permeability of those sands increases along with the longer time of reclamation. In the case of mechanical-

cryogenic reclamation one can observe a drop of permeability in the sand prepared with reclaim processed in a reclamation unit for a time longer than 10 minutes. This is due to the effect of the sand grains being crushed, which is observed after this time and proved by the successively made screen analyses. Crushing of the sand grains reduces their diameter, raises the specific surface, and changes their shape from rounded to a sharp-edged one, as proved by examinations of the grain surface morphology.

3. CONCLUSIONS

The studies described here indicate that the reclamation of used moulding sands with water glass conducted in the range of extra-low and cryogenic temperatures is fully justified from the technological point of view. The mechanical-cryogenic reclamation obviously improves the reclamation output in the case of both investigated sand types, subjected to reclamation in the same reclamation unit, which has all the features of a plant of the traditional design, commonly used for the mechanical reclamation process.

It can be stated that the currently used processes of reclamation with application of extra-low temperatures are the only ones which among all other well-known techniques of the reclamation can effectively utilise the hygroscopic behaviour of moulding sands as a factor intensifying the process of releasing the sand grains from a binding material. The presence of a "freezing" agent changes the volume of both binder and sand grains, leading to increased stresses on the grains surface and inside the grains, combined with higher brittleness of the binding material.

Compared to most of the currently used mechanical reclamation units operating under ambient conditions, the same equipment when adapted to operation at low temperatures, may in a short time produce the sand grains of better technological parameters. This is very advantageous not only in respect of the process economy but, first and foremost, in respect of the environmental protection, as it provides us with a tool making the use of larger amounts of the reclaim in the newly prepared sand possible, which quite obviously should reduce the volume of the post-production waste.

At this point, however, attention should be drawn to the fact that the mechanical-cryogenic reclamation of sands

with either water glass or bentonite may, if not adequately controlled, lead to a much quicker wear of the sand grains and formation of large volumes of the dust.

Aknowledgements

The studies were done within AGH own research programme, №. 10.10.170.187

REFERENCES

1. **Holtzer, M., Kargulewicz, I.** Leaching of Cd, Cu, Pb, and Zn from Used Sands as a Criterion for Estimate Harmfulness *III International Conference "Modern Foundry Technologies – Environmental Protection*, Kraków, 7–9 September, 2000: pp. 87–92.
2. Used Foundry Sand – Classification and Disposal. EPA (Environmental Protection Act) Guidelines. Re-issued September 2003.
3. **Good, G., Hoyt, D. F. et al.** Total Sand Reclamation. AFS Special Report, July 1987: pp. 30–34.
4. **Leidel, D. S.** The Influence of Sand and Binders on Reclaimability *Foundry Trade Journal* Issue 3497 168 1994: pp. 384–387.
5. **Lewandowski, J. L., Solarski, W., Zawada, J.** Toxicity of Moulding Sands with Bentonite and Coal Dust *Solidifications of Metals and Alloys* 35 1998: pp. 67–76.
6. **Tordoff, W. L., Miller, J., Trembly, J.** New Development in Sand Reclamation. CIATF Technical Forum, 1999: pp. 377–386.
7. **Tordoff, W. L.** Could Cryogenics Crystallize as an Option for sand Reclamation? *Modern Casting*, Aug. 1998: pp. 35–37.
8. **Dańko, J., Dańko, R.** Low Temperature Reclamation Treatment of Water-Glass Bonded Sands *Archives of Foundry* 4 (11) 2004: pp. 102–107.
9. **Dańko, R.** Re-using the Sand Reclaimed by Various Reclamation Processes in Preparation of Core Sands *International Conference "Modern Methods of Core Production"*, Milovy, Czech Republic, 2003: pp. 123–130.
10. **Dańko, J., Dańko, R.** Reclaimability of Used Self Setting Sand with Selected Type of Resin *Archives of Foundry* 4 (13) 2004: pp. 45–50.
11. **Dańko, J., Holtzer, M.** Reclaimability of Core and Mould Sands with Various Kind of Resins *First International Symposium For Foundry Chemical Resins* Sharm El-Sheikh, Egypt, 15–18 February, 2004: p. 19.

DOI: 10.5755/j02.ms.26548