

Determination of the Modulus of Elasticity, Poisson's Ratio and the Coefficient of Thermal Expansion of Electrochemically Metallized Nickel Coatings

Harri LILLE*, Jakub KÕO

Institute of Forestry and Rural Engineering, Estonian Agricultural University, Kreutzwaldi 5, Tartu 51014, Estonia

Received 08 June 2005; accepted 21 July 2005

A four-point bending method is developed for determination of the modulus of elasticity and Poisson's ratio in a nickel coating deposited by electrochemical metallizing from a sulphate electrolyte on a brass strip substrate. For determination of the coefficient of thermal expansion the strip substrate was heated with and without the coating. The method involves use of strain gauges that are attached on the free surfaces of substrate and the coating. The sensitivity of the method was studied and the uncertainty of the computed mean values of the modulus of elasticity, Poisson's ratio and the coefficient of thermal expansion are presented.

Keywords: nickel coating, strain gauge, elastic modulus, Poisson's ratio, coefficient of thermal expansion, uncertainty.

1. INTRODUCTION

In order to determine properties and characteristics as residual and thermal stresses, fracture toughness and fatigue crack growth rate of galvanic coatings, it is necessary to know their modulus of elasticity, Poisson's ratio and the coefficient of thermal expansion (CTE) [1, 2]. Determination of these characteristics for coating materials is difficult as coatings are thin and are attached to a thicker substrate. Since coatings are used while bound to a substrate, it is still desirable to determine the modulus of elasticity, and the coefficient of thermal expansion in situ.

The material of a nickel coating deposited by electrochemical metallizing [3] (brush-plating) from a sulphate electrolyte on a brass strip substrate is examined [4].

The experimental equipments were developed for deposition of a coating and for four-point bending of a strip substrate without and with the coating. Adequate calculation formulae are presented for determination of the modulus of elasticity and the CTE of nickel coating material. The readings of the strain gauge attached to the surface of the substrate and the coating, and the bending moment, acting on the gauge section, obtained by a weight, or by a load caused by temperature change, serve as quantities.

Poisson's ratio was calculated in relation to the strain records of the transverse and longitudinal directions measured on the free surfaces of the coating.

The uncertainty of the calculated values of the modulus of elasticity, CTE and Poisson's ratio are determined. The dispersion of the readings within the measured data are added to standard uncertainty, and expanded uncertainty is the calculated. Thus calculated quantities are obtained serving the input in the calculating formulae in order to determine, e.g. residual stresses.

2. MEASUREMENTS

2.1. Modulus of elasticity of the coatings material

The modulus of elasticity of the substrate and coating materials was determined by four-point bending with a load applied to the ends of a strip substrate using calibrated weights (Fig. 1). The deformation of the free surface of the substrate or the coating was measured with a strain gauge. The modulus of elasticity of the coating material was calculated, according to laminated (bimetal) beam bending theory, using an iterative method and insertion of the values of the modulus of elasticity until the measured and the calculated longitudinal strains of the free surface of the substrate or the coating, respectively, were equal [5].

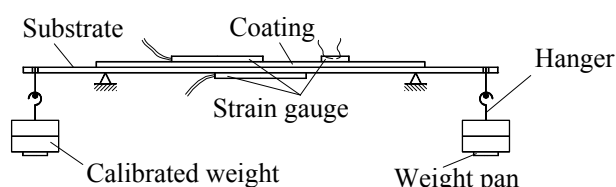

Fig. 1. Experimental equipment and a coated substrate for four-point bending test

The longitudinal strain is calculated by formula

$$\varepsilon_l = \frac{M(z+a)}{E_2 I_2 + E_1 I_1}, \quad (1)$$

where M is the applied bending moment, $I_1 = \frac{b((h_1 - e)^3 + e^3)}{3}$, $I_2 = \frac{b((h_2 + e)^3 - e^3)}{3}$, I_1 and I_2 are the moments of inertia of the substrate and coating, respectively; E_1 , E_2 are the moduli of elasticity of the substrate and coating, respectively, b is the width of the substrate; the distance of the reduction surface from the interface between the coating and the substrate is expressed as follows:

*Corresponding author. Tel.: +372-7-313181; fax: +372-7-313154
E-mail address: harri.lille@eau.ee (H.Lille)

$$e = \frac{h_1^2 - \gamma h_2^2}{2(h_1 + \gamma h_2)},$$

where $\gamma = E_1/E_2$ and h_1 is substrate thickness, h_2 is coating thickness and z is the distance from reduction surface to free surface of substrate or coating, a is distance from the free surface to the centre the cross section of the wires of the strain gauge (in our case about 0.06 mm) (Fig. 2).

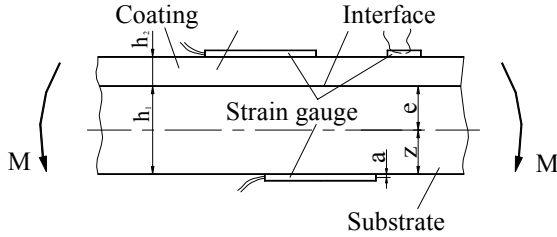

Fig. 2. Scheme for calculating the modulus of elasticity and Poisson's ratio of the coating

The modulus of elasticity of the substrate is obtained as follows:

$$E_1 = M(z+a)/I\varepsilon_1, \quad (2)$$

where $I = bh_1^3/12$ is the moment of inertia of the substrate without coating, ε_1 is longitudinal strain of the substrate.

Poisson's ratio was calculated as follows:

$$\mu_2 = |\varepsilon_t/\varepsilon_l|, \quad (3)$$

where ε_t and ε_l are the strain records of the transverse and longitudinal directions of the free surface of the coating.

2.2. Coefficient of thermal expansion of coating material

To determine the coefficient of thermal expansion of the coating, the specimen was heated in a thermostat. The longitudinal strain ε_1 of the free surface of the substrate without and with the coating in the state of free bending, corresponding to temperature change, was measured. Then the coefficient of thermal expansion was calculated as follows [6]:

$$\alpha_2 = \frac{\varepsilon_1(h_1^4 + 4\gamma h_1^3 h_2 + 6\gamma h_1^2 h_2^2 + 4\gamma h_1 h_2^3 + \gamma^2 h_2^4)}{h\gamma\Delta T(4h_1^3 + 3h_1^2 h_2 + \gamma h_2^3 - 6(h_1 + h_2)(h_1 + a)h_1)} + \alpha_1, \quad (4)$$

where α_1 is the coefficient of thermal expansion of the substrate (which is known), ΔT is temperature change.

2.3. Analysis of uncertainties of measured parameter values

Combined uncertainty can be expressed as relative standard deviation. Denoting $w(x_i) = u(x_i)/\bar{x}_i$, where \bar{x}_i is the mean value of x_i and relative combined uncertainty is calculated by formula [7, 8]:

$$u_c(y) = \sqrt{\sum_{i=1}^N w^2(x_i)}. \quad (5)$$

Expression (5) shows that the combined uncertainty of the estimate y is equal to the sum of the relative dispersions of the input estimates x_i , N are input quantities.

Evaluation of a standard uncertainty case can be obtained by the following formula

$$u(x_i) = \sqrt{\frac{1}{n(n-1)} \sum_{j=1}^n (x_{i,j} - \bar{x}_i)^2}, \quad (6)$$

where

$$\bar{x}_i = \frac{1}{n} \sum_{j=1}^n x_{i,j}, \quad (7)$$

where \bar{x}_i is the mean of the input estimates $x_{i,j}$, n are independent specimens.

The dispersions of the readings within of the measured data can be expressed by the assumed square distribution

$$u(\bar{x}_i) = s_p/3, \quad (8)$$

where s_p is the semi-interval of the fluctuating value of the strain indicator.

This uncertainty is added to standard uncertainty

$$u_c(y) = \sqrt{w(x_i)^2 + w(\bar{x}_i)^2}. \quad (9)$$

Then expanded uncertainty is calculated by the following formula:

$$U = k u_c(y), \quad (10)$$

where k is the coverage factor. If $k=2$, expanded uncertainty is defined by the interval with a level of confidence of approximately 95%.

3. EXPERIMENTAL DEVICE AND PROCEDURE

The experimental measuring system (see Fig. 3) used for coating a substrate consists of the following components: stylus, experimental device for fixing the substrate, continuous measurement and recording of deformations and temperature during the process of coating. The stylus was swabbed over the area where the coating was to be deposited (for more detail see our paper [4]).

A nickel coating with a thickness of about 0.06 mm was deposited from an electrolyte elaborated by M. Pille, Ph D (Estonian Agricultural University), containing Ni SO₄ × 7 H₂O, 350 g/litre; HCOOH, 60 g/litre; HCOONa × 2 H₂O, 40 g/litre; MgSO₄ × 7 H₂O, 10 g/litre; gravity 1.19 ± 0.01 g/cm³, pH = 1.57 – 1.63 (determined at 20 °C), to a brass strip substrate with the dimensions 72.0 × 22.0 × 0.95 mm, coated length 50 mm (Fig. 4). Current density was 60 – 64 A/dm² and the ratio of the anode surface to the surface to be coated was 1 : 4.

The strip with and without coating was loaded by four-point bending by $M = 146.8$ Nmm (Fig. 1). Deformations were measured using wire strain gauges (base length 20 mm in the longitudinal direction and 10 mm in the transverse direction, resistance 200 Ω, gauge factor 2.1 at 20 ± 1 °C) glued onto the free surfaces of the substrate or the coating, and the results were stored in a multi-channel strain indicator supplied with a processor. Calibration of the strain gauges yielded the factor 3.06×10^{-6} pps.

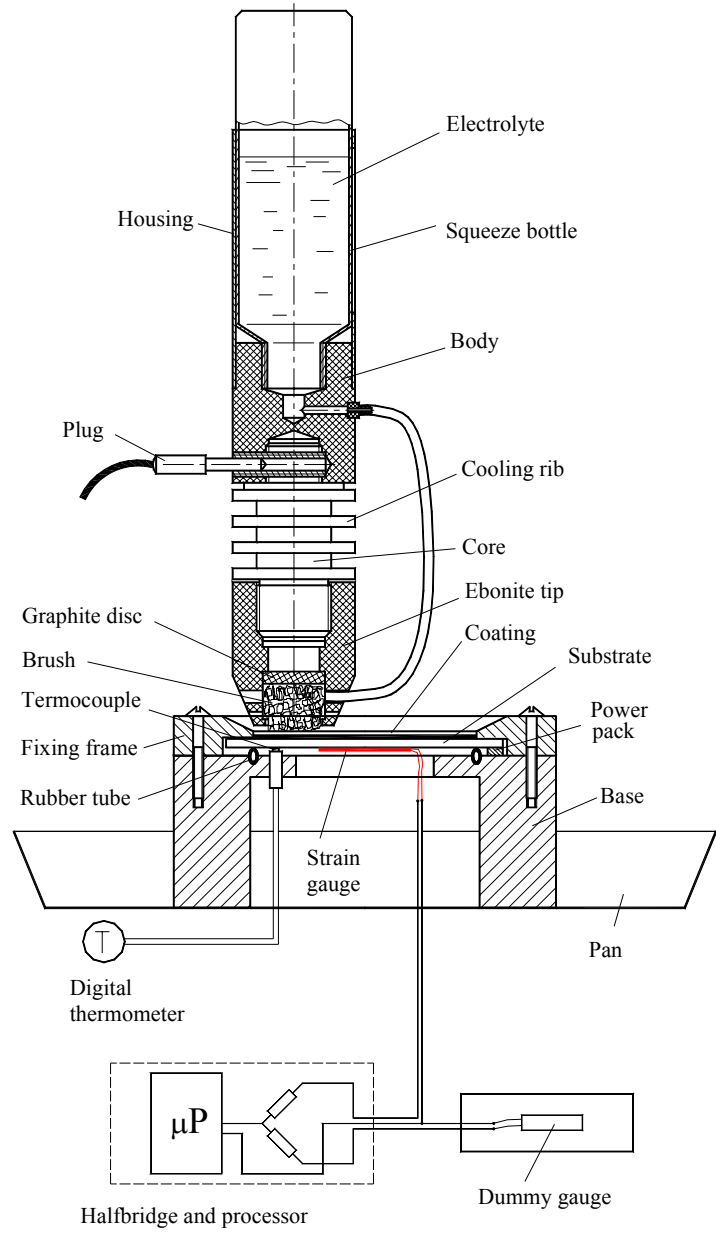

Fig. 3. Experimental system

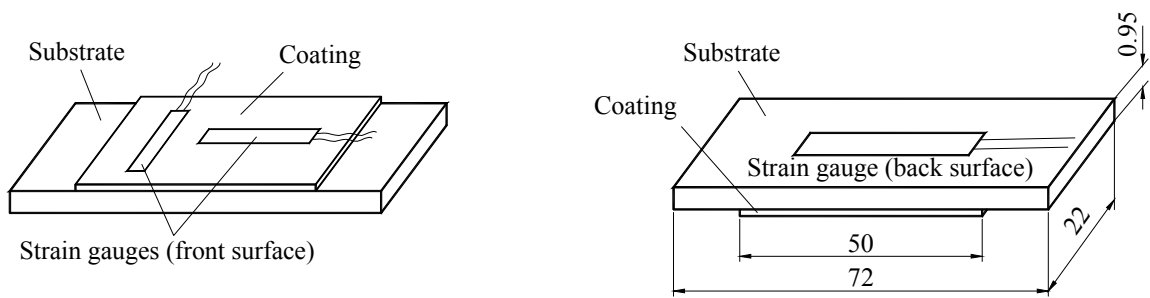

Fig. 4. Geometry of the specimen

4. EXPERIMENTAL RESULTS

Altogether 16 specimens were analyzed allowing calculation of standard uncertainty.

The modulus of elasticity of the substrate material was determined by formula (2).

The mean value was 9.91×10^4 N/mm² with a standard uncertainty of 0.066×10^4 N/mm², the mean value of the strain gauge reading was 509 $\mu\epsilon$ with a maximum uncertainty of 2.5 $\mu\epsilon$, yielding expanded uncertainty of 1.6 %. The obtained modulus of elasticity of the strip was $(9.91 \pm 0.16) \times 10^4$ N/mm² (in [9] 1.08×10^4 N/mm² for mild brass).

The modulus of elasticity of the coating material was calculated using formula (1).

The mean value of the modulus of elasticity was 1.63×10^5 N/mm² with a standard uncertainty of 0.11×10^5 N/mm², mean value of the strain gauge reading was 302 $\mu\epsilon$ with a maximum uncertainty of 2.5 $\mu\epsilon$ and expanded uncertainty was 13.5 %. The obtained modulus of elasticity of nickel material was $(1.63 \pm 0.22) \times 10^5$ N/mm² (in [2] for nickel 2.07×10^5 N/mm²).

The handbook [10] presents the values for moduli of elasticity of nickel coatings deposited in a bath (e. g. for electroless deposited nickel, 1.2×10^5 N/mm², and for electroplated nickel, 2.1×10^5 N/mm²), in [11] for electroplated nickel from Watt's bath $(1.46 - 1.87) \times 10^5$ N/mm².

Poisson's ratio was calculated by formula (3). The mean value was 0.324 with a standard uncertainty of 0.00713, mean value of the strain gauge reading in the transverse direction was 98 $\mu\epsilon$ with a maximum uncertainty of 2.5 $\mu\epsilon$, and expanded uncertainty was 6.7 %. The obtained Poisson's ratio of the nickel coating material was 0.324 ± 0.022 (in [2] 0.31 for nickel).

The coefficient of thermal expansion was calculated using formula (4), where the $\alpha_1 = 2.04 \times 10^{-5}$ 1/°C [9]), temperature change $\Delta T = 50$ °C.

The mean value was 1.249×10^{-5} with a standard uncertainty of 0.0572×10^{-5} , mean value of the strain gauge reading was 79.6 $\mu\epsilon$ with a maximum uncertainty of 2.5 $\mu\epsilon$, and expanded uncertainty was 11.1 %. The obtained CTE for nickel coating material was $(1.249 \pm 0.139) \times 10^{-5}$ 1/°C (in [2] 1.33×10^{-5} 1/°C for nickel).

The handbook [11] presents 1.46×10^{-5} 1/°C for nickel coating deposited from Watt's bath and 1.36×10^{-5} 1/°C from sulfamate bath.

Sensitivity analysis showed that the expanded uncertainty of the determined parameters can be up to 13.5 %, which is sufficiently accurate (for moderately unstable electrochemical metallizing processes) for applications of practical interest.

5. CONCLUSIONS

1. The modulus of elasticity of nickel coating material is lower than that of a nickel for wrought counterpart, but it is comparable to the values obtained for electroplated nickel.
2. The values of Poisson's ratio and the CTE of the nickel coating material are comparable with those of a nickel-wrought counterpart, but the obtained CTE is lower than for nickel deposited in the bath.
3. The significant uncertainty of the modulus of elasticity and Poisson's ratio is caused by the dispersion of the experimental readings of the strain gauges in the direction of bending.
4. The calculated values of CTE of the coating are the most sensitive to the uncertainties of the readings caused by the strain indicator (uncertainty about 2.5 $\mu\epsilon$ and mean strain readings about 80 $\mu\epsilon$).

REFERENCES

1. **Dini, J. W.** Electrodeposition. The Materials Science of Coatings and Substrates. Noyes Publications, New Jersey, 1993.
2. **Doi, O., Ukai, T.** Residual Stress Measurement of Multi-Layered Plate by curvature Method *Bulletin of the JSME* 14 (67) 1971: pp. 1 – 10.
3. **Rubinstein, M.** Electrochemical Metallizing. Van Norstrand Reinhold Company Inc., New York, 1987.
4. **Lille, H., Kõo, J., Pihl, T.** Measurement of Residual Stresses in Brush Plated Nickel Coatings *Proc. 3rd Int. Conf. DAAAM Nat. Est. (Eds. J. Papstel, B. Katalinic)*, Tallinn, 2002: pp. 185 – 188.
5. **Boyarchinov, S. V.** Fundamentals of Machine Structural Mechanics. Machinostroyeniye, Moscow, 1973 (in Russian).
6. **Kõo, J.** Determination of Residual Stresses in Coatings and Coated Parts *Thesis of Dr. Sc. Eng.* Tallinn Technical University, Tallinn, 1994.
7. **Laaneots, A.** Reliability of Measured Result. Tallinn Technical University Press, 2004 (in Estonian).
8. **Taylor, B. N., Kuyatt, C. E.** Guidelines for Evaluating and Expressing the Uncertainty of NIST measurements Results. NIST Technical Note 1297, 1994. <http://www.physics.nist.gov/Pubs/>.
9. Handbook for Metal-Worker. Handbook in Five Volumes. Second Volume. Eds. **A. C. Rakhshad, V. A. Brostrem.** Machinostroyeniye, Moscow, 1976 (in Russian).
10. Handbook of Tribology: Materials, Coatings, and Surface Treatments. Eds. **Bharat Bhushan, B. K. Gupta.** McGraw-Hill, Inc., 1991.
11. A Handbook. The Properties of Electrodeposited Metals and Alloys. Ed. **William H. Safranek.** American Electroplaters & Surface Finishers S; 2nd edition, 1986.

DOI: 10.5755/j02.ms.26551