

Heat Balance of Prototype Plasma Furnace for Melting Reactive Metals

Andrzej MODRZYŃSKI*, Krzysztof GRZEŚKOWIAK

Institute of Materials Technology, Poznań University of Technology, 3 Piotrowo Str., 60-965 Poznań, Poland

Received 13 June 2005; accepted 01 September 2005

In this paper the construction and heat balance of prototype stand for plasma melting of reactive alloys are described. The operating parameters of prototype stand during making the testing melts of titanium alloys are presented. Such parameters like arc current, mean arc voltage in plasma arc, discharge of water for plasmatron/cold crucible/working chamber cooling systems and output and input temperature of water were investigated as well. During testing melts several thermocouples were fixed in characteristic point of furnace to determine temperature distribution inside and outside the melting chamber. Automatic computer measuring stand was used for recording the changes of temperature as a function of time. The heat balance described in this paper was obtained during melting titanium alloy grade Ti-6Al-4V at decreasing pressure (10 – 13 kPa) in melting chamber with use of helium as a plasma working gas. The melting process was divided into two stages : stage I – six minutes with using second tap of transformer and stage II – three minutes with using third tap of transformer. Temperature distributions in furnace during testing melt are presented in this paper as well. Heat balance presented in this paper has shown that the thermal efficiency in stage I was 49.8 % and in stage II was 63.9 %. Thermal efficiency of the prototype plasma furnace is on the same level as in any other plasma furnaces described in technical literature.

Keywords: plasma furnace, heat balance, titanium alloys, thermal efficiency.

1. INTRODUCTION

In many electric heating engineering technologies an electric arc is used as a strong source of heat. Among many forms of plasma arcs the DC gas stabilized arc burning between plasmatron (cathode) and metal furnace charge is very often used. The possibilities of high temperature obtained and easy control of thermal parameters is an advantage of this kind of heating. These includes [1 – 4]:

- designing and research of plasma torches for metallurgical application,
- application of low temperature plasma for melting, refining and recycling of metals and casting alloys.

The plasma furnaces introduced to metallurgical processes have the following advantages in comparison to the classic ones [5 – 7]:

- they allow to obtain a high temperature in the working chamber and easily controllable working conditions,
- they are characterized by easy control of the power supplied to the furnace,
- they are characterized by high concentration of power transferred in the volume unit of the plasma arc,
- they create conditions for free shaping of gaseous phase of the furnace by the rational selection of the gas used for plasma generation,
- their feature is high intensity of transferring heat from the plasma arc to the molten metal.

Melting titanium and its alloys is very difficult because of [5 – 7]:

- titanium is reactive metal which reacts actively at a higher temperature with oxygen and nitrogen from the furnace atmosphere making oxide and nitrides,
- solubility of hydrogen in titanium and its alloys is very high,
- molten titanium reacts with most refractory materials commonly used for manufacturing refractory crucibles.

Therefore, metallurgical units used for melting titanium and its alloys should satisfy the following conditions :

- melting should be performed in vacuum or inert atmosphere,
- the crucible used for melting titanium should not react with alloys components,
- the furnace should be capable of metal overheating up to temperature of 1800°C thanks to the used of heat source of large energy concentration.

The prototype laboratory stand for melting reactive metals and alloys was built a few years ago and is presented. This laboratory furnace for melting reactive metals at decreased pressure consists of the following basic elements:

- working chamber with water cooling system,
- DC arc plasmatron with a hollow cathode adapted for work at decreased pressure with the supply and cooling systems,
- plasmatron supply system with working gas (argon, helium) with device for purifying the working gas and measurement of gas pressure and flow intensity,
- vacuum installation with a system for cooling waste gases and equipment for measure the composition of gaseous phase and its pressure.

*Corresponding author. Tel.: +48-61-6652423; fax.: +48-61-6652217.
E-mail address: andrzej.modrzynski@put.poznan.pl (A.Modrzynski)

For melting titanium alloys the cold crucible made of copper with cooling system was applied. The construction of cold crucible is presented in Fig. 1.

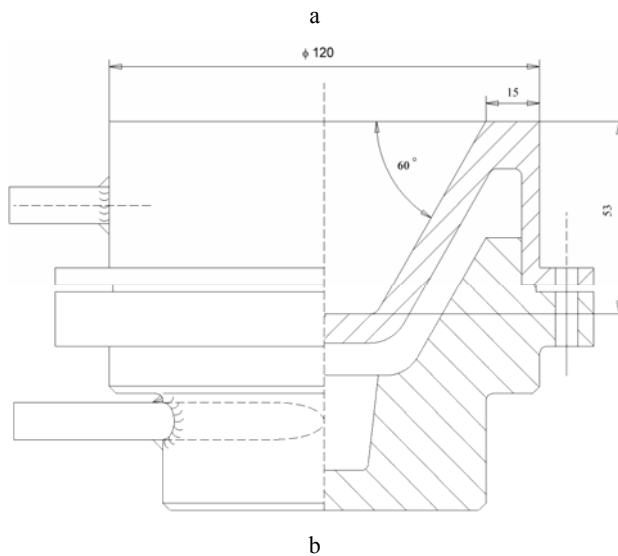

Fig. 1. Cold crucible: a – melting chamber with cold crucible, b – construction of cold crucible

Due to the kind of molten metal, the Ti-6Al-4V titanium alloys, it was necessary to use water-cooled copper crucible which enables to carry out heats of very high metallurgical quality [5]. Conducting heats in the water-cooled copper crucible, in which a solidified metal layer acts as a furnace lining, is a difficult technological task. Melting and overheating molten metal up to the temperature of about 1800 °C requires detailed determining of cooling water consumption (the speed of heat radiation), which would guarantee that a skull layer of sufficient thickness is created. Maintaining the skull layer during melting process is very important from a point of view the safety of the people operating the plasma furnace.

The laboratory stand was equipped with a prototype DC arc plasmatron with hollow cathode. This plasmatron is presented in Fig. 2.

2. THERMAL BALANCE OF A PLASMA FURNACE

The thermal balance of prototype plasma furnace preparing for making melts in the conditions of decreasing pressure was made during melting a scrap of titanium alloys Ti-6Al-4V. The melting process was carried out at decreasing pressure (10 – 13 kPa) with applying helium as a working gas. The melting process consisted of two stages:

- the first one with duration about 6 minutes was carried out with applying the second top of the transformer,
- the second one (with applying the third top of the transformed) with duration about 3 minutes was carried out was used for preheating the liquid metal.

The working parameters during the tests melts were varied in the following ranges:

Pressure in furnace chamber	– 4.9 – 90.6 kPa;
Working gas	– He;
Arc current intensity	– 420 – 680 A;
Arc voltage	– 23 – 42 V;
Power supplied	– 9.66 – 28.56 kW.

The amount of thermal energy taking part in the process of charge melting can be determined by making thermal balance of a metallurgical furnace. Such a balance also allows further research directed at possibilities of applying computer programs for simulating and optimizing metal melting process. During particular experimental heats, the authors recorded the values of parameters necessary to make the thermal balance and measured temperature distribution in the laboratory plasma furnace, using a computer stand for data acquisition.

The energy balance of a furnace has following components:

$$Q_p = Q_{cp} + Q_{ct} + Q_{pt} + Q_{pl} + Q_{pm} + Q_g + Q_a, \quad (1)$$

where Q_p is the heat flux generated by plasma torch, Q_{cp} is the heat flux carried away by plasmatron cooling system, Q_{ct} is the heat flux carried away by crucible cooling system, Q_{pt} is the heat flux carried away by crucible by radiation, Q_{pl} is the heat flux carried away from an arc by radiation and convection, Q_{pm} is the heat flux carried away from molten metal by radiation and convection, Q_g is the

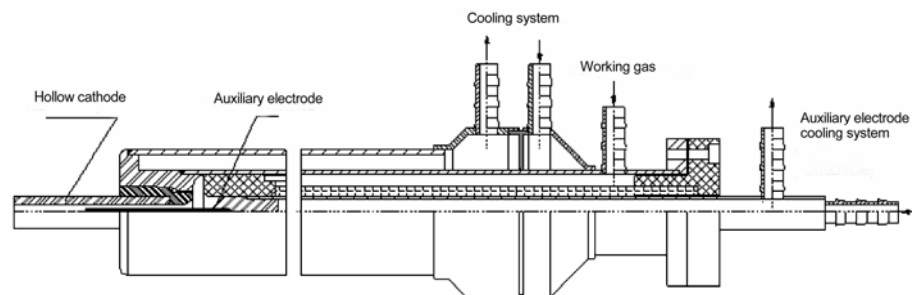

Plasmatron PPNA 1/99 DC-E-Ar

Fig. 2. Plasma torch for working in low pressure [1, 2]

Table 1. Heat balance of prototype furnace [4]

Equation	Data for stage 1	Data for stage 2	Result for stage 1	Result for stage 2
$Q_p = U \cdot I$	$U = 39 \text{ V}; I = 449 \text{ A}$	$U = 46 \text{ V}; I = 770 \text{ A}$	$Q_p = 17511 \text{ J/s}$	$Q_p = 35420 \text{ J/s}$
$Q_{cp} = m \cdot c_w \cdot \Delta T$	$m = 0.085; c_w = 4150; \Delta T = 22$	$m = 0.085; c_w = 4150; \Delta T = 26$	$Q_{cp} = 7760 \text{ J/s}$	$Q_{cp} = 9171 \text{ J/s}$
$Q_{ct} = m \cdot c_w \cdot \Delta T$	$m = 0.06; c_w = 4150; \Delta T = 35$	$m = 0.101; c_w = 4150; \Delta T = 54$	$Q_{ct} = 8715 \text{ J/s}$	$Q_{ct} = 22634 \text{ J/s}$
$Q_{cpw} = m \cdot c_w \cdot \Delta T$	$m = 0.033; c_w = 4150; \Delta T = 4$	$m = 0.033; c_w = 4150; \Delta T = 16$	$Q_{cpw} = 548 \text{ J/s}$	$Q_{cpw} = 2191 \text{ J/s}$
$Q_{cd} / Q_{cpw} = (2 \cdot S_d) / S_{cpw}$	$S_d = 0.3129; S_{cpw} = 1.131;$ $Q_{cpw} = 684$	$S_d = 0.3129; S_{cpw} = 1.131;$ $Q_{cpw} = 2191$	$Q_{cd} = 378 \text{ J/s}$	$Q_{cd} = 1212 \text{ J/s}$
$Q_g = m_{\text{He}} \cdot c_{\text{He}} \cdot \Delta T_{\text{He}}$	$m_{\text{He}} = 1.482 \cdot 10^{-4}; c_{\text{He}} = 5234;$ $\Delta T = 4$	$m_{\text{He}} = 1.482 \cdot 10^{-4}; c_{\text{He}} = 5234;$ $\Delta T = 30$	$Q_g = 3 \text{ J/s}$	$Q_g = 23 \text{ J/s}$
Q_a			$Q_a = 107 \text{ J/s}$	$Q_a = 189 \text{ J/s}$

m , m_{He} – flux of cooling water and helium, [kg/s]; ΔT – temperature difference between outlet and inlet of cooling water and helium, [K]; c_w , c_{He} – specific heat of water and helium, [J/kg·K]; S_d – surface of bottom part of the melting chamber, [m²]; S_{cpw} – surface of the chamber cooling jacket, [m²].

heat flux carried away by exhauster with working gas by pumping system from chamber to external atmosphere, Q_a is the heat flux carried away by the anode of the furnace.

The heat emitted by the crucible, plasma arc, and the upper surface of the molten metal and the heat radiated by convection will be absorbed by furnace walls. This we can state that:

$$Q_{pl} + Q_{pl} + Q_{pt} = Q_{cd} + Q_{cpw}, \quad (2)$$

where Q_{cpw} – is the heat flux carried away by furnace walls cooling system, Q_{cd} is the heat flux carried away by the top and bottom of the furnace chamber.

Then:

$$Q_p = Q_{cp} + Q_{ct} + Q_{cpw} + Q_{cd} + Q_g + Q_a. \quad (3)$$

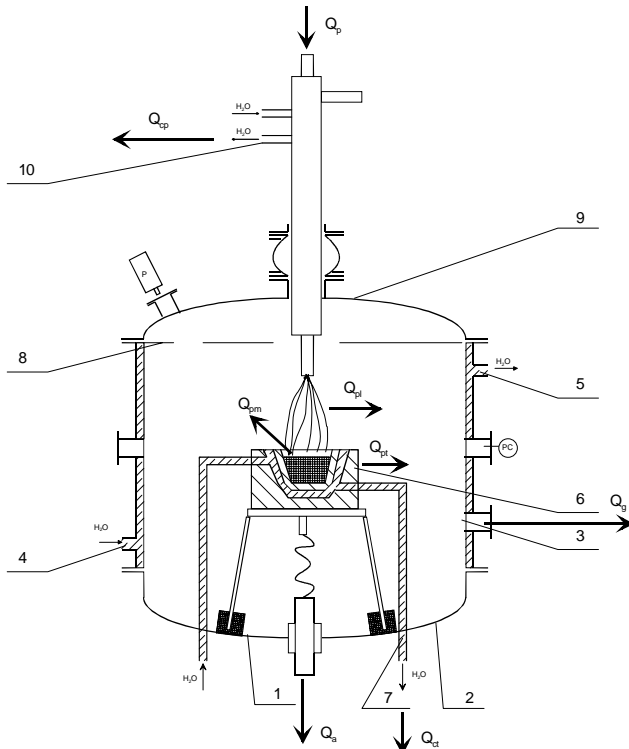
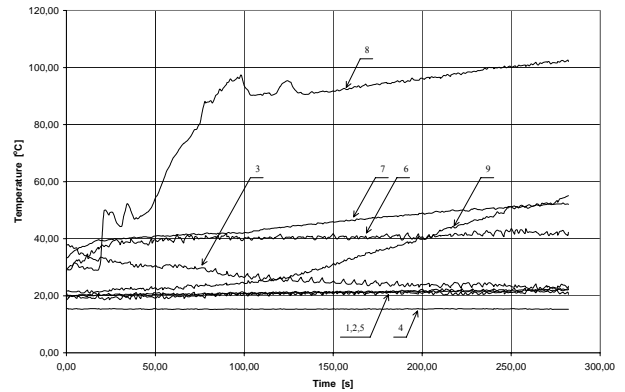

Fig. 3. Scheme with the points of thermoelements location and heat transfer direction [4]

For one of the testing melts the heat balance was made. The furnace was equipped with thermocouples to determine the temperature distribution at characteristic points of system.

The scheme of the furnace with points of temperature measurement was presented in Fig. 3. Temperature changes during testing melt in defined point of plasma furnace (point 1 – 9) during first and second stage of melting process are presented in Fig. 4.



a

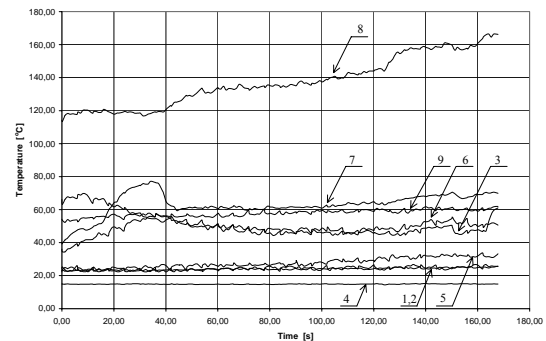

b

Fig. 4. Temperature changes during testing melt in defined point of plasma furnace: a – II tap of transformer, b – III tap of transformer (point 1 – 9 see Fig. 3)

Detailed results necessary for making thermals balance have been determined after the heating parameters have been stabilized. During the testing melt the temperature of external surface wall of cold crucible was at the same level as the temperature of cooling water (about 70 °C). So, the assumption that

$$Q_{pt} = 0 \quad (4)$$

was made.

The parameters necessary for making heat balance were specified in Table 1.

Analysis of the results of heat fluxes during the testing melt allows to determine the thermal efficiency of the melting process from the relation

$$\eta = (Q_{cp} / Q_p) 100, \% \quad (5)$$

The thermal efficiency for stage one was about 49.8 % and for the second stage 63.9 %.

3. CONCLUSIONS

On the basis of the research, we can state that:

- the main elements of plasma laboratory furnace construction were working well,
- we receive the thermal coefficient of titanium melting process on the level which is presented in the literature [8] for plasma furnace,
- the cold crucible was working well and the assumptions of its construction were correct,
- the new construction of DC plasma torch with hollow cathode was working very well as the heat source.

REFERENCES

1. **Modrzyński, A., Niewiedzial, R., Namyślak, R.** Application of Arc Plasmatron for Melting Metals at Decreased Pressure *Proc. of IX International Conference – Switching Arc Phenomena* Publ. by Łódź TU, Poland, 2001: pp. 248 – 25.
2. **Modrzyński, A., Grzeškowiak, K., Namyślak, R.** Prototype Stand for Plasma Melting of Metals *Proc. Of 7th International Conference – TECHNOLOGY 2001, Bratislava Slovak TU* Vol.II 2001: pp. 532 – 534.
3. **Modrzyński, A., Lybacki, W.** Analysis of Deoxidation and Degassing of Cast Carbon Steel in Plasma-type Induction Furnace *Scientific proceedings of the International Congress Mechanical Engineering “TECHNOLOGIES’97” – Foundry Section, Bulgaria* Vol. 3 (12) September 1997: pp. 11 – 16.
4. **Modrzyński, A., Grzeškowiak, K.** Heat Balance of Prototype Plasma Furnace for Melting Reactive Metals *Archives of Mechanical Technology and Automatization* 24 (2) Poznań, Poland, 2004: pp. 187 – 195.
5. **Szweycer, M., Modrzyński, A., Lybacki, W., Jackowski, J.** Physical and Chemical Conditions of Melting Titanium and Titanium Alloys *Proceedings of First Symposium “Processing of Titanium and Titanium Alloys”* Publ. by Poznan University of Technology. Poznan, Poland, 1991: pp. 13 – 20.
6. **Krone, K.** Production and Properties of Precision Investment and Compact Castings in Titanium Alloys *Giesserei* 65 (20) 1978: pp. 540 – 549.
7. **Krone, K.** Herstellung, Eigenschaften und Verwendung von Titanguss. Teil I: Schmelz – und Giessverfahren, Formstoffsysteme *Metall* 30 Jg H. 6 1976: s. 556 – 559.
8. **Dembowski, V.** Plasma Metallurgy. Elsevier Science Pub. Co., 1985.

DOI: 10.5755/j02.ms.26552