

Wood Bandsaw Blade Rigidity: the Impact of Sawblade Dimensions and Strain

K. Ukvalbergienė*, A. Baltrušaitis, V. Prancėvičienė

Department of Mechanical Wood Technology, Kaunas University of Technology,
Studentų 56, LT-3031 Kaunas, Lithuania

Received 30 September 2003; accepted 29 October 2003

The productivity and sawing accuracy of band sawing machines are highly dependent on stable operation of band sawblades, thus the study was aimed to ascertain the influence of blade thickness, blade width, blade length, blade tension and loading on sawblade rigidity during operation and how the quality of sawing with changing sawblade tension changes. During the study, the dependence of sawblade deflection on side loading was investigated. Side force of band sawblades comprised 10 N, imitating destabilizing the saw loading. The studied band sawblades were 0.5 – 1.0 mm in thickness, 16 – 108 mm in width, and 600 – 1200 mm in length. The results of investigation show, that the greatest influence on operational stability of the band sawblades has actual tension power and sawblade free length. A rather high influence was demonstrated by sawblade width and thickness as well. The paper presents obtained relationships and conclusions.

Keywords: band sawblade, rigidity, stability, blade length, blade width, blade thickness, guides.

1. INTRODUCTION

The productivity and sawing accuracy of band sawing machines highly depends on stable operation of band sawblades. The ability of band sawblades to resist side force i.e. their ability to sustain flat equilibrium form under loading is characterized as rigidity [1]. The loss of equilibrium of band sawblade preconditions the appearance of wavy sawing, breakdown losses and other undesirable phenomena.

Three kinds of rigidity are distinguished: j_c – natural rigidity of unstrained sawblade, which depends on sawblade length, cross-sectional parameters (width and thickness) and the condition of sawblade itself after rolling; j_H – initial rigidity of unstrained sawblade in the absence of sawing force; j_d – operational rigidity of sawblade, taking into account sawing force [2].

To ascertain operational sawblade rigidity, according to which sawing accuracy is estimated it is necessary to know j_H . It is ascertained according to side force Q and caused by it sawblade deflection y :

$$j_H = \frac{Q}{y}. \quad (1)$$

Calculation scheme to ascertain sawblade bend is shown in Fig. 1.

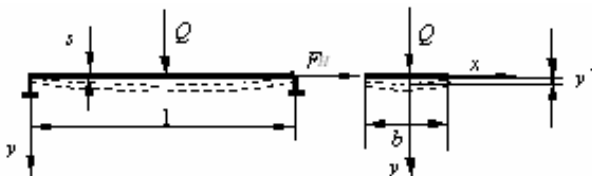

Fig. 1. Scheme of side force Q influence: s – sawblade thickness, b – sawblade width, l – sawblade length, F_H – tension force, Q – side force

The operational sawblade rigidity is calculated according to formula:

$$j_d = j_H \left(1 - \frac{P^2}{P_{cr}^2} \right), \quad (2)$$

where P is the maximal value of normal sawing force, N; P_{cr} is the critical value of normal sawing force, under which sawblade loses stability, N.

The condition of precision sawing determines, that maximal sawblade deflection y_{max} during sawing should not exceed allowable value [3]:

$$y_{max} \leq [y]. \quad (3)$$

Thus, the condition of precision sawing is

$$y_{max} = \frac{Q}{j_H \left(1 - \frac{P^2}{P_{cr}^2} \right)} \leq [y], \quad (4)$$

where Q is the side resistance force when sawing; j_H is the initial sawblade rigidity, MPa.

Therefore, the condition of precision sawing shows that sawing accuracy depends on the forces affecting the sawblade (Q, P) and on the ability of the sawblade to resist the forces (j_H, P_{cr}). The value of critical force P_{cr} depends on geometrical parameters of the sawblade, sawblade free length, tension force, relative eccentricity of sawblade tension, as well as on the condition of sawblade tension due to rolling. Increase of relative eccentricity of sawblade tension to a certain size, called optimal, effects on increase of critical force. Further increment of eccentricity leads to the reduction of critical force. Installation of sawblade with optimal eccentricity allows increasing their stability up to 30 % [1].

The stability of sawblades is influenced by various factors, both of technological and instrumental character: forces acting within wood sawing zone, geometrical sawblade parameters and sawblade operational length, tension force, uneven heating of sawblades according to length and width.

*Corresponding author. Tel.: + 370-650-59832; fax.: + 370-37-353863.
E-mail address: reference@email.lt (K. Ukvalbergienė)

In order to increase the precision of sawn details, it is necessary to reduce side forces, to increase sawblade rigidity and stability during operation. Band sawblades are insufficiently rigid. Therefore, in purpose to increase sawing precision, sawblades are often strained using too high force, which leads to metal fatigue and significant reduction in durability of the tool. Optimal tension of band sawblades is 100 – 150 MPa. Greater tension force damages the sawblade.

A force ensuring required sawblade rigidity should strain band sawblade. Tension force F_H is equal

$$F_H = 2\sigma_H sb, \quad (5)$$

where b is the band width, mm; s is the band thickness, mm; σ_H is the tension, ensuring stable operation of a sawblade.

When band thickness increases, band stability improves [4]. The higher is band tension force, the less influence theoretically has its thickness on band stability. This explains the opinion, that with decreasing thickness and increasing tension, band stability is sustained or even improved, while losses due to saw kerf decrease. Highly drawn band is characterized by almost 40 % better stability despite the fact that it is by 25 % thinner. This is a philosophy of high tension/thin kerf [4].

The changes in blade width may lead to astonishing results. Theoretically, small changes do not show any greater effect. Band stability may become even worse with increasing width. It may be caused by side force affecting the top of saw teeth and rotation of the band. When band width increases, the appearance of a longer lever shoulder and greater rotation moment increase destabilizing band movements (data by UDDEHOLM company [4 – 5]). Literature sources by Russian scientists point out on the contrary, i.e. with decrease band width from 160 to 80 mm, critical force decreases by 31 % [1].

Distance between band guides influences band stability during sawing [6 – 7]. The greater is free distance, the worse is the stability. However, some practical tests reveal that the effect is not so great as it is shown in theory. One explanation in this case is that logs are often sawn close to the lower guide and thus the band is operating having a sufficiently good support, however it is not completely proved yet.

Band tension is an important field for investigation in order to improve band stability, therefore this study seeks to ascertain what influence on bandsaw rigidity during operation has band thickness, width, free operational length, tension, loading and how sawing quality changes with changing sawblade tension.

2. EXPERIMENTAL

The stability of bandsaws may be static and dynamic. Static stability is characterized by the magnitude of critical force under which the sawblade loses its balance form and bends [8].

Dynamic stability is characterized by the appearance of changing loadings, owing to which resonance oscillations of the blade appear and consequently the saw loses its ability to resist sawing forces. Then straight-linear sawing becomes impossible.

Practically the loss of dynamic stability is not observed because of sawing precision decrease long before attaining such a condition. The calculation of dynamic stability is rather complicated thus in this paper only static stability is presented.

During this study the deflection of sawblade due to side loading was investigated. The sawblades were subjected to 10 N forces loading (it was constant during the study). The thickness, width and length of studied saws were 0.5 – 1.0 mm, 16 – 108 mm and 600 – 1200 mm respectively.

A special stand was used to measure the tension and deflection of sawblades (Fig. 2).

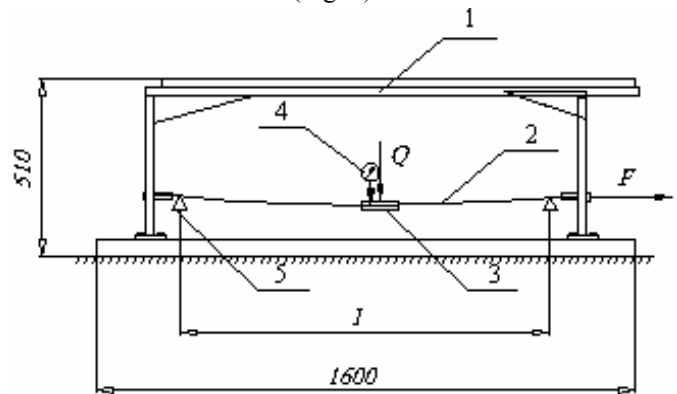

Fig. 2. Sawblade tension stand: 1 – frame; 2 – sawblade; 3 – tension measurer “Sandvik 5000”; 4 – deflection indicator; 5 – support; l – free operational length ($l = 600 - 1200$ mm)

In this stand on one side the saw is fixed stationary, while on the other side sawblade tension may be changed by tightening bolt. On the back or toothed edge of the bandsaw the band tension measurer (tensometer) “Sandvik 5000” is fastened. The pointer of the instrument is connected to its sensor. The sensor consists of a differential transformer with installed oscillator and demodulator. Measuring length of the sensor is 206 mm, maximal depth – 15 mm. Maximal measuring limit is 600 MPa.

Having strained the sawblade up to 10 MPa, in its center a load of 10 N is placed and deflection indicator is provided. During the experiment tension was changed every 10 MPa and the deflection was measured. The interval of tension applied was 0 – 150 MPa.

Any measurement gives not precise value of the measured size, but only an approximate, i.e. more or less close to the precise value. During sawblade tension testing value deviations of deflection indicator, tensometer and weight as well as measurement errors should be taken into account. The error of bend indicator is 0.01 mm, that of tensometer 1 MPa. The error of 1000 g weight imitating side force is 2.5 g.

In this way sawblades of different thickness, widths and lengths were studied.

3. RESULTS AND DISCUSSION

Analyzing the data obtained it was found that sawblade rigidity during operation depends on blade thickness, width, length and blade tension. Figure 3 shows that when blade tension $\sigma = 10$ MPa, the greater the length

of the sawblade, the greater is its deflection (almost linear dependence is obtained).

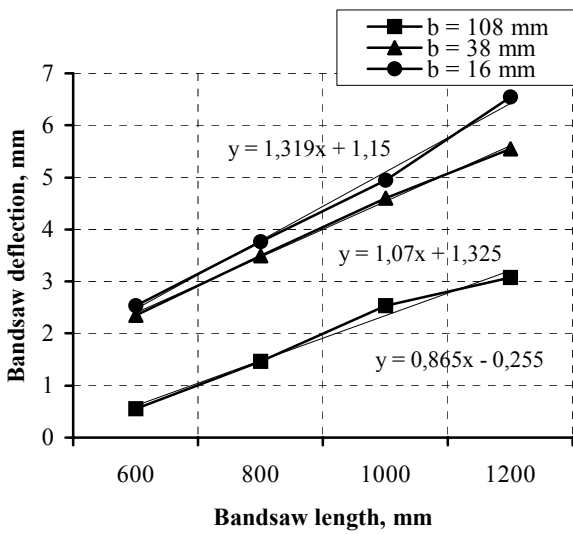

Fig. 3. Dependence of blade deflection on free operational length. Blade tension $\sigma = 10$ MPa

The greater is blade length, the greater is the distance between guides, which have a high influence on blade stability during sawing. The longer is free operational zone the worse is blade rigidity.

Figure 4 shows when $\sigma = 100$ MPa that when blade width $b = 108$ mm, blade deflection is significantly less and with increasing blade length it increases slower than that of narrower blades which have $b = 16$ mm.

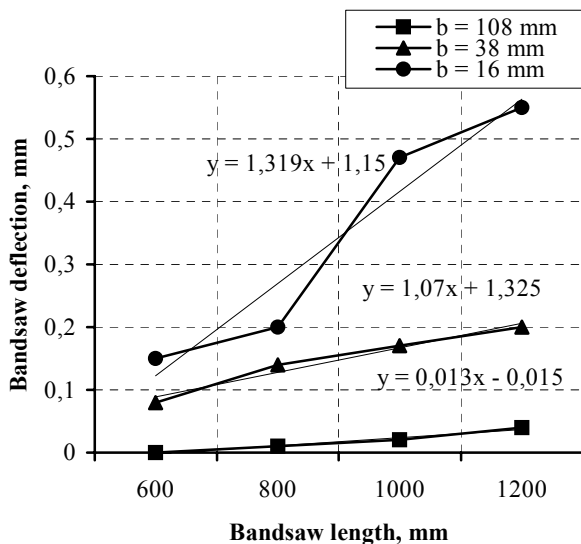

Fig. 4. Dependence of blade deflection on free operational zone. Sawblade tension $\sigma = 100$ MPa

When the length of free operational zone is $L = 1200$ mm, blade width $b = 16$ mm, then blade deflection is $y = 0.55$ mm, and when blade width $b = 108$ mm, blade deflection $y = 0.04$ mm. Thus it may be stated that using wider blades higher rigidity may be obtained under the same tension. However, with greater width increases the

shoulder of blade torsion torque, due to which greater side forces start affecting the saw and it begins to vibrate resulting in wavy cut. It is especially observed using wide thin blades thus wider blades are produced of greater thickness. However, in this case increases losses due to saw kerf, which in modern wood processing industry is very irrational.

When the blade width increases (Fig. 5), the deflection decreases and the shorter is the length of free operational zone, the smaller the deflection is.

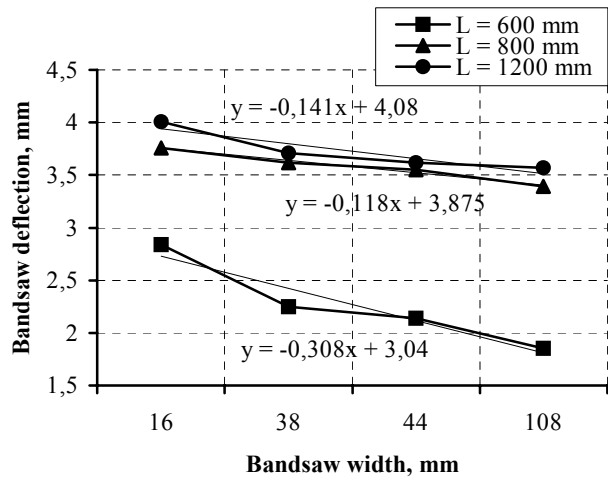

Fig. 5. Dependence of blade deflection on blade width, when $\sigma = 10$ MPa

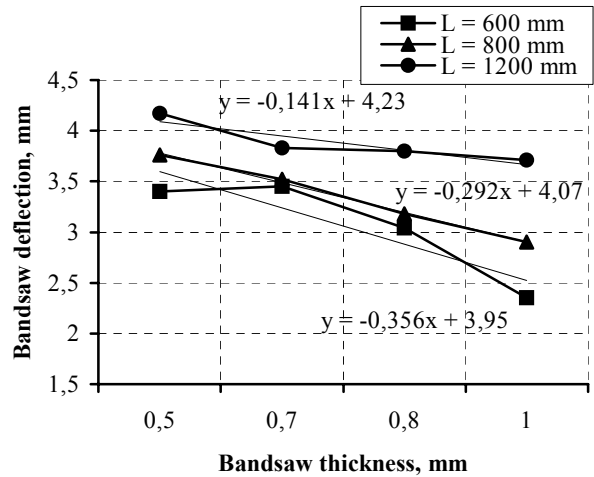

Fig. 6. Dependence of blade deflection on blade thickness, when $\sigma = 10$ MPa

Therefore, using and designing new bandsaws it is actual to reduce free blade length as much as possible. An example could be sawblades with aerostatic guides, in which this length is minimal, thus blade rigidity increases several times. Besides, such bandsaw have more advantages: increases blade durability due to greater bending radius of guides and less tension; it is possible to use blades the teeth of which have hard alloy edge; increases reliability of bandsaw operation, because there is no radial beating of pulley inertia; decrease the dimensions

and metal consumption; more simple is manufacturing of such bandsaws [9].

With the increase of blade thickness the stability of blade during operation improves (Fig. 6). When blade thickness $s = 0.5$ mm, blade deflection $y = 3.49$ mm, and when blade thickness $s = 1$ mm, blade bend $y = 2.35$ mm (this is related also to the fact, that thicker blades are wider). However, increasing blade thickness decreases wood output. This problem is usually solved by reducing blade thickness and increasing tension, but doing it in this way, especially in Lithuania, i.e. drawing blades “visually”, without tension measurers, leads to their spoiling due to overtension, causing the appearance of fissure between teeth, etc.

The greater is blade tension the higher is blade rigidity during operation, however tension is limited due to possible metal fatigue. Tension force especially affects narrow and thin blades.

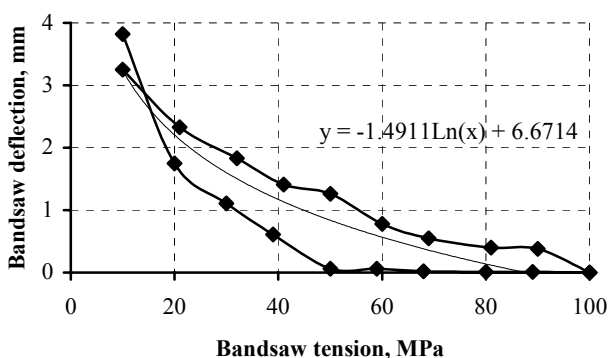

a

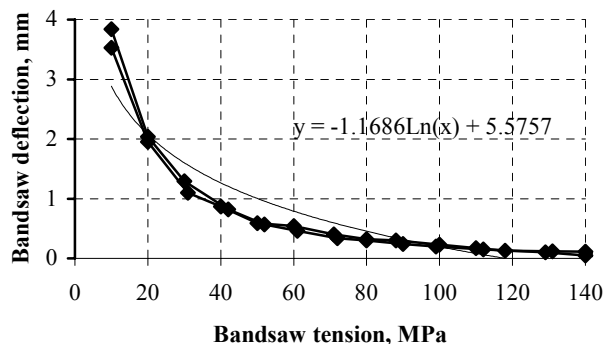

b

Fig. 7. Dependence of blade deflection on blade tension: a) dependence of a sawblade operating for a long time on tension, when blade length $L = 800$ mm, blade thickness $s = 1$ mm, blade width $b = 108$ mm; b) dependence of a new sawblade on tension, when blade length $L = 800$ mm, blade thickness $s = 1$ mm, blade width $b = 38$ mm

Figure 7 shows that straining and loosening a new sawblade (b), data almost coincide, while straining and loosening a blade which has been operating for a long time (a), a hysteresis loop is obtained. It may be explained by the fact that residual deformation appears on a long-operating blade due to regular tensioning and loosening.

Thus, it is very important to use tension measurers, so that every time blade is strained applying the same force (100 – 150 MPa). Therefore, it can be seen that the tension of blade is one of the most important blade longevity factors.

4. CONCLUSIONS

1. The rigidity of band sawblades is the most important factor preconditioning sawing efficiency. Rigidity depends on free length, blade cross-sectional parameters (width and thickness) and tension condition after rolling. In purpose to increase sawing precision, blades are often drawn using too great forces, which leads to metal fatigue and the longevity of the tool highly decreases.

2. The longer is free operational zone the worse is blade rigidity. It is especially obvious when thinner blades are used. When blade width $b = 16$ mm, blade length $L = 600$ mm, the blade deflection $y = 2.54$ mm (blade tension $\sigma = 10$ MPa), when blade length $L = 1200$ mm, then blade deflection $y = 6.54$ mm. When blade width $b = 108$ mm, while blade length $L = 600$ mm, then deflection $y = 0.55$ mm, when blade length $L = 1200$ mm, blade deflection $y = 3.08$ mm. When blade tension reaches $\sigma = 100$ MPa, influence of its width on rigidity increases. For wide blades when $b = 108$ mm tension force of 100 MPa is optimal, while for narrow blade when $b = 16$ mm, deflection changes from $y = 0.15 \div 0.55$ mm (depending on the length of free operational zone). Such blades should be drawn using greater force (about 150 – 160 MPa).

3. With the increase blade width, blade rigidity increases. Analyzing short free zone blades ($L = 600$ mm), the width of which $b = 108$ mm, even initial rigidity, when $\sigma = 10$ MPa, was sufficiently good ($y = 0.55$ mm), while initial rigidity of blades with blade width $b = 16$ mm was $y = 2.54$ mm. However, wider blades are more expensive, because more metal is consumed for their production, it is difficult to saw curvilinear kerfs with them and they are more affected by side forces.

4. The thicker is the blade, the greater is band stability during sawing. When blade thickness $s = 0.5$ mm, blade deflection $y = 3.49$ mm, while when blade thickness $s = 1$ mm, blade deflection $y = 2.35$ mm. However, it is irrational to use thick blades in modern wood processing industry because highly increase wood losses due to sawing kerf. The use of thin blades saves wood but either a higher tension or a reduction of feeding rate by 20 – 40 % under each 0.2 mm thickness reduction is required.

5. When blades are drawn at higher than allowable force (100 – 150 MPa), this causes blade overtensioning. A permanent deformation appears on blades. Many Lithuanian sawmills lack tension measurers for strain calibration. Blades are drawn “visually”, while after the appearance of permanent deformations it is impossible to draw the blades each time using the same desirable force. Therefore, wood processing precision decreases, while blades have to be exchanged earlier than they should serve. Enterprises then suffer considerable losses.

REFERENCES

1. **Prokofjev, G. F.** Intensification of Wood Sawing with Frame Saws and Bandsaws. Moscow, Lesnaja promislennost, 1990 (in Russian).
2. **Ivankin, I. I.** Theoretical Research of the Initial Rigidity of Bandsaws *Forestry Journal ISSN 0536-1036* 3 2000: pp. 112 – 119 (in Russian).
3. **Prokofjev, G. F.** Main Trends of Intensification of Wood Sawing with Saw-frame and Band Sawing Machines *Forestry Journal ISSN 0536-1036* 6 1998: pp 53 – 65 (in Russian).
4. How to Increase profit in Bandsawing. Woodtooling information. Stockholm, Sweden, Uddeholms Aktiebolag, No. 837, 2000: 44 p.
5. Wood Bandsaw Blade Manual. Stockholm, Sweden, Uddeholms Aktiebolag, 2000: 48 p.
6. **Williston, E. M.** Saws. Design, Selection, Operation, Maintenance. USA, 1989: 450 p.
7. Production, Use and Maintenance of Wood Bandsaw Blades. A Manual from Sandvik Steel. AB Sandvik Steel, Sandviken, 1999: 136 p.
8. **Bogdanov, E. A., Ostroumov, I. P.** Preparation and Maintenance of Frame Saws. Moscow, Lesnaja promislennost, 1986 (in Russian).
9. **Prokofjev, G. F., Ivankin, I. I.** Stability of the Saw of Band Sawing Machine with Curvilinear Aerostatic Guides *Forestry Journal ISSN 0536-1036* 1 2001: pp. 67 – 74 (in Russian).

DOI: 10.5755/j02.ms.26598