

Investigation of Mechanical Parameters and Defects of Solid Wood Glued Panels

D. Albrektas* J. Vobolis

Faculty of Design and Technology, Kaunas University of Technology, Studentų 56, LT-3031 Kaunas, Lithuania

Received 30 September 2003; accepted 24 October 2003

The group of glued wooden articles comprises glued beams, wooden panels and plywood. Glued joints may be considered as heterogenous systems where the parameters of separate components greatly differ. The main reasons of low – quality gluing include insufficient compression strength and gluing temperature as well as greasy or unsuitably rough surface. Therefore, production of wooden articles and selection of suitable wood require knowledge not only on wood, but also on mechanical parameters of different joints, such as strength, stiffness, damping etc. In this paper the method and equipment of estimation of mechanical parameters of scantling panels is presented. Two types of panels were selected for the study. To study the effect of possible low – quality gluing and other defects, a defect in the panel was imitated by making an incision in the gluing zone. The resonance vibrations method was used for investigation.

Keywords: dynamical modulus of elasticity, coefficient of damping, resonance vibration, glued wooden panel, defects.

INTRODUCTION

The group of glued wooden articles usually comprises glued beams, wooden panels and plywood.

Scantling panels are made of wooden pieces (scantlings) by gluing their edges. There exist one – layer and multi – layer panels. They are used for general and construction proposes in dry, humid environment and open air. Scantling panels are produced from coniferous or deciduous wood, using non – solid and solid pieces. Their surface may be unsanded, sanded, relief and finished (veneered, painted etc.) [1 – 3].

Scantling panels are used to produce various furniture articles, partition – walls, ceilings, joinery articles etc. Sometimes they may be applied for sound absorption or insulation, or its intensification. Therefore, production of wooden articles and selection of suitable wood require knowledge not only on wood, but also on mechanical parameters of different joints, such as strength, stiffness, damping etc.

The main reasons of low – quality gluing include insufficient compression strength and gluing temperature, as well as greasy or unsuitably rough surface. Besides, gluing of wood of improper moisture content may in the long run lead to deformations in glue lines and wood itself.

Glued joints may be considered as heterogenous systems, where the parameters of separate components greatly differ.

Mechanical parameters of wood and wooden articles are ascertained by testing them statically and dynamically.

Bending strength and modulus of elasticity may be ascertained by static panel testing.

Most investigations are conducted by testing articles dynamically.

The major portion of dynamical study methods are based on forcing study object to vibrate, and these vibrations help to define physico–mechanical parameters [4 – 7]. The advantage of dynamical study methods, as compared to the static ones, lies in the fact, that study

objects remain undestroyed, usually it is unnecessary to produce special specimens and a better and more precise assessment of defects is possible.

The aim of this work was to estimate the mechanical parameters and defects of scantling panels by the resonance oscillations method.

THEORETICAL BACKGROUND

Most small details of wooden articles are of a beam or plate form. The construction of scantling panels is close to that of plates.

It is known, that mechanical parameters of plates made from different materials are ascertained using resonance vibrations.

The classical vibration equation of a flexible plate is sufficiently precise until the length of bending wave of the plate is at least 5 times greater than the thickness of the plate. This equation looks as follows [8, 9]:

$$\alpha^4 \nabla^4 \xi + \frac{\partial^2 \xi}{\partial t^2} = p, \quad (1)$$

where

$$\nabla^2 = \frac{\partial^2}{\partial x^2} + \frac{\partial^2}{\partial y^2} \quad \text{and} \quad \alpha^4 = \frac{h^2 E}{12(1-\nu^2)\rho},$$

here h is the thickness of the plate, ν is the Poisson's ratio, E is the modulus of elasticity, p is the exciting force per area unit of the plate, ρ is the density of the material; ξ is the function of variables x , y and t .

This equation may be applied if the distance from the edge of the plate to the point of vibration is greater than the thickness h of the plate.

If the plate is fixed so that its perimeter is in xOy plane, then boundary conditions are:

$$\xi = 0, \frac{\partial \xi}{\partial r} = 0 \quad \text{or} \quad \frac{\partial \xi}{\partial x} = \frac{\partial \xi}{\partial y} = 0. \quad (2)$$

In case the plate rests on its edges, boundary conditions are:

$$\xi = 0, \frac{\partial^2 \xi}{\partial r^2} + \nu \frac{\partial^2 \xi}{\partial s^2} = 0, \quad (3)$$

* Corresponding author. Tel./fax: +370-37-353863
E-mail address: Darius.Albrektas@stud.ktu.lt (D. Albrektas)

where s – is the coordinate in direction of perimeter so, that M_s - bending moment in respect of edge tangent of the plate and r – coordinate would be in the direction of the normal to this line.

Transverse oscillations of freely placed rectangular plate (Fig. 1) may be described by the following function:

$$\xi = V_{mn} \sin \frac{mx\pi}{l_1} \sin \frac{ny\pi}{l_2} \cos w_{mn}t, \quad (4)$$

where $m, n = 1, 2, 3, \dots, l_1, l_2$ – length and width of the plate, respectively, w_{mn} – resonance frequencies expressed as follows:

$$w_{mn} = w_{ap}m^2 + w_{bp}n^2, \quad (5)$$

where

$$w_{ap} = \frac{\alpha^2 \pi^2}{l_1^2}, \quad w_{bp} = \frac{\alpha^2 \pi^2}{l_2^2},$$

$$\alpha^4 = \frac{h^2 E}{12(1-\nu^2)\rho} = \frac{c_p^2 h^2}{12(1-\nu^2)},$$

where α – coefficient, $c_p = (E/\rho)^{1/2}$ – is the sound speed in a pivot made from the same material as the plate.

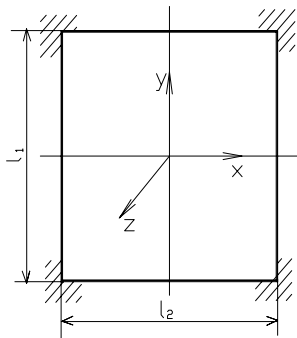

Fig. 1. Freely fixed plate: l_1, l_2 – length and width of the plate, respectively

Thus knowing the resonance frequency of the plate, the form of resonance curve, density of the material and dimension, it is possible to ascertain modulus of elasticity and the coefficient of damping.

Resonance oscillations were applied to estimate mechanical parameters of scantling panels and to ascertain their defects.

STUDY METHODS AND EQUIPMENT

A panel of glued scantlings from natural wood is not a uniform solid article. Physico-mechanical parameters (density, modulus of elasticity) of each scantling differ. Besides, the properties of glue lines differ as well. Thus, the regularities of oscillations of solid plates are not fully applicable to the scantling panels. This will also influence the amplitude – frequency dependencies of scantling panels. Scheme of the stand used during studies is presented in Fig. 2.

Loudspeaker 4, controlled by the generator of electric oscillations 8, excites resonance oscillations of the panel. For this purpose the frequency of the generator's oscillations is changed. These oscillations are recorded by the measuring element 9 fixed in certain places of the

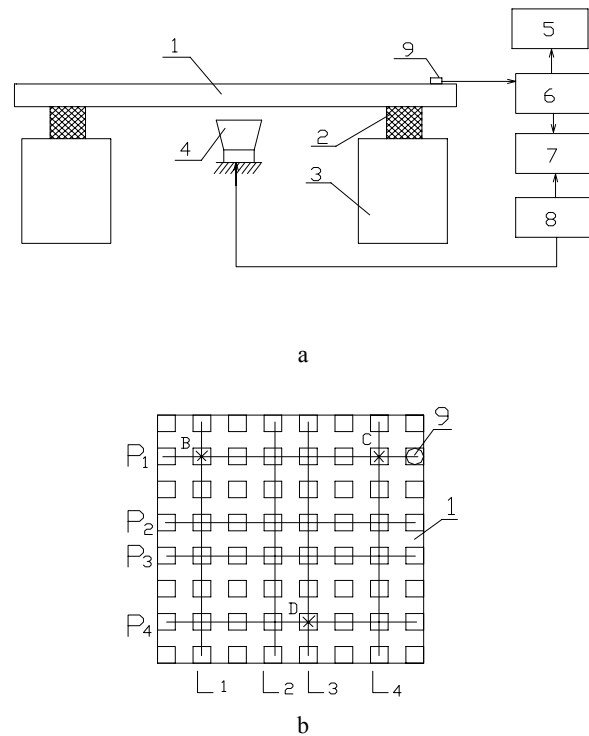

Fig. 2. Scheme of the study equipment (a) and location of measuring element (b): 1 – scantling panel, 2 – elastic polypropylene elements, 3 – supports from natural wood, 4 – loudspeaker, 5 – oscilloscope, 6 – measuring device, 7 – phasometer, 8 – generator of electric oscillations, 9 – measuring element, $L_1 - L_4$ – panel stripes in longitudinal direction, $P_1 - P_4$ – in perpendicular direction

panel. Their amplitude is measured using device 6. To ascertain the direction of panel bending, the phase of oscillations is measured by a phasometer 7. The phasometer receives signal from the measuring device and the generator. For a more accurate ascertainment of the form of bending, 91 (I) and 64 (II) panel zones were chosen. In these zones the measuring element was fixed and oscillations were recorded, i. e. their amplitude and phase were measured.

EXPERIMENTAL DATA

Two types of panels were selected for the study. Their dimensions were: I – 1800×900 mm and II – 700×700 mm, thickness 30 mm. Some bending forms of scantling panels are presented in Fig. 3, while resonance frequencies are given in Table 1.

It can be observed, that resonance frequencies depend on the dimensions of panels. The frequencies of their similar oscillation forms differ approximately 2 – 4 times. Having studied panels it can be stated, that their stiffness, similarly to solid wood, is greater in the longitudinal direction of fibres (scantlings in panels are glued only in respect of width). The panel bends in the longitudinal direction (longitudinally to glue lines) under almost 3 times higher frequency, than in a similar form in perpendicular direction. Further studies were conducted with the panel of type II.

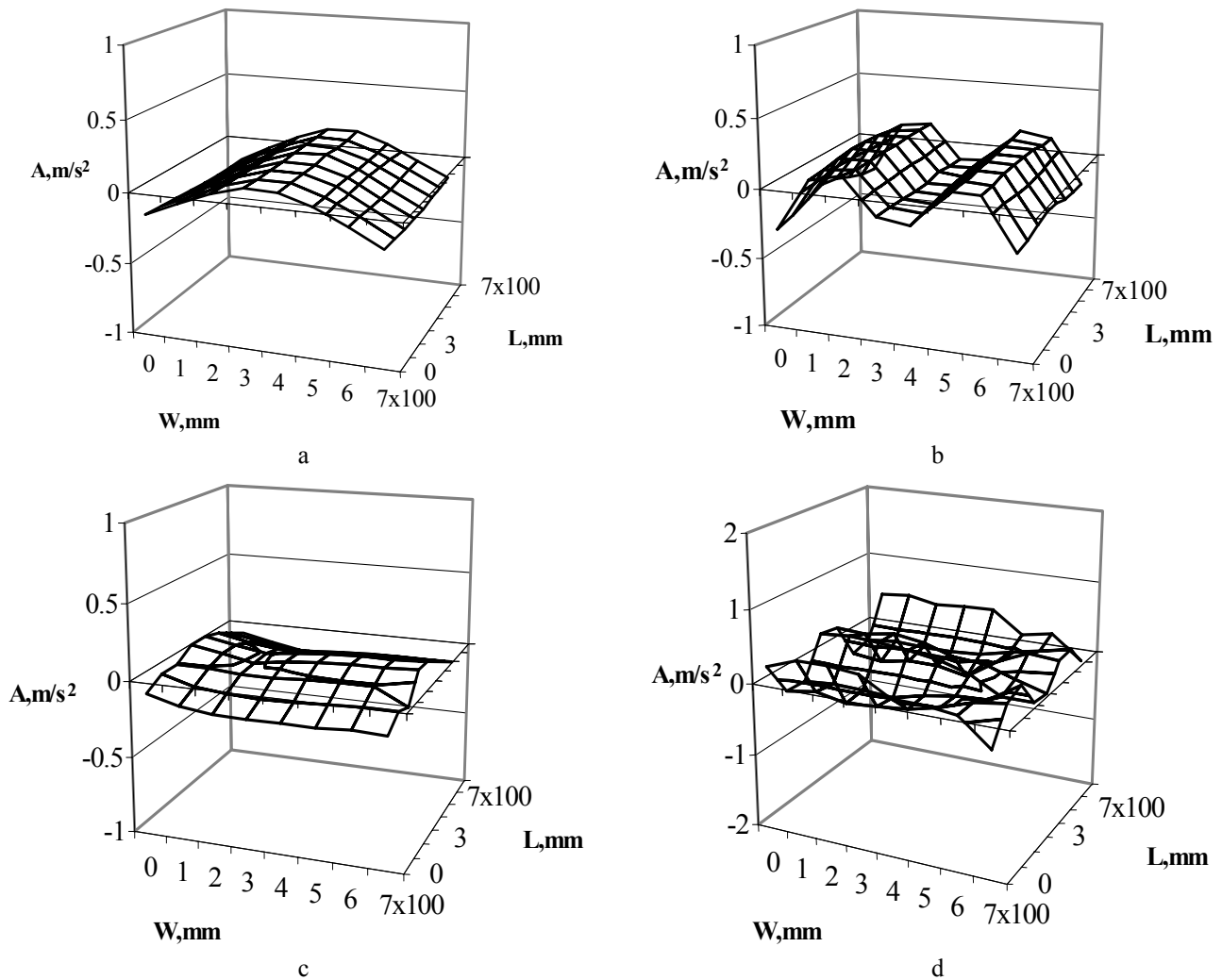

Fig. 3. Bending forms of the studied panels in perpendicular (a, b) and longitudinal (c, d) directions: a – $f = 93$ Hz, b – $f = 500$ Hz, c – $f = 235$ Hz, d – $f = 1390$ Hz, A – amplitude of oscillation acceleration, m/s^2 , L – length of the panel, W – width of the panel

Table 1. Resonance frequencies of scantling panels

Panel	Resonance frequencies, Hz				
I	20.6	24.7	28.2	42	50
	113	225	262	295	320
	500	555	610	700	855
II	93	194	235	265	318
	430	500	700	760	840
	1180	1270	1390	1480	1880

For processing of the results some characteristic zones were selected in the studied panel (Fig. 2, b). Their area comprises about 4 cm^2 . The zones B and C are close to the corners of the panel, while zone D is close to its edge. In these zones the amplitude and phase of oscillations vary to the highest degree. Their amplitudes under resonance frequencies are shown (Fig. 4). It can be seen, that the greatest amplitude of oscillations of the panel is attained under frequencies of 265, 430, 840 and 1390 Hz. Further studies were focused on the changes of amplitudes under these frequencies.

In the studied panel stripes P_1 , P_2 , P_3 and P_4 were singled out in perpendicular direction, while in longitudinal direction – L_1 , L_2 , L_3 and L_4 (Fig. 2, b).

These stripes were chosen not randomly – P_1 and P_4 show, how the panel bends in perpendicular direction at the sides, P_2 and P_3 – in the middle. L_1 , L_4 and L_2 as well as L_3 show, how the panel bends in longitudinal direction. The distribution of oscillation amplitude of points within these strips is shown in diagrams (Fig. 5).

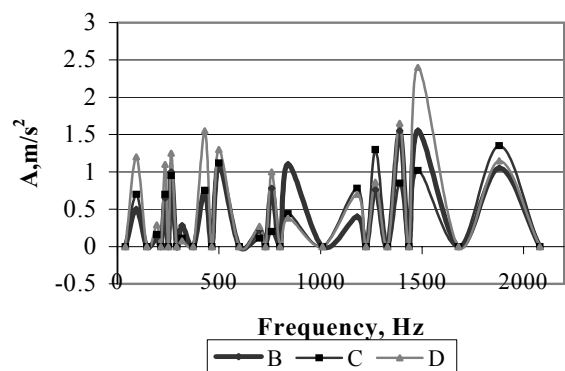

Fig. 4. Variation regularities of oscillation amplitudes in characteristic panel zones

Under some, especially lower resonance frequencies (93, 235 Hz), vibration of both sides of the panel have similar amplitudes ($0.1 - 0.13 \text{ m/s}^2$) (Fig. 5, b), while the

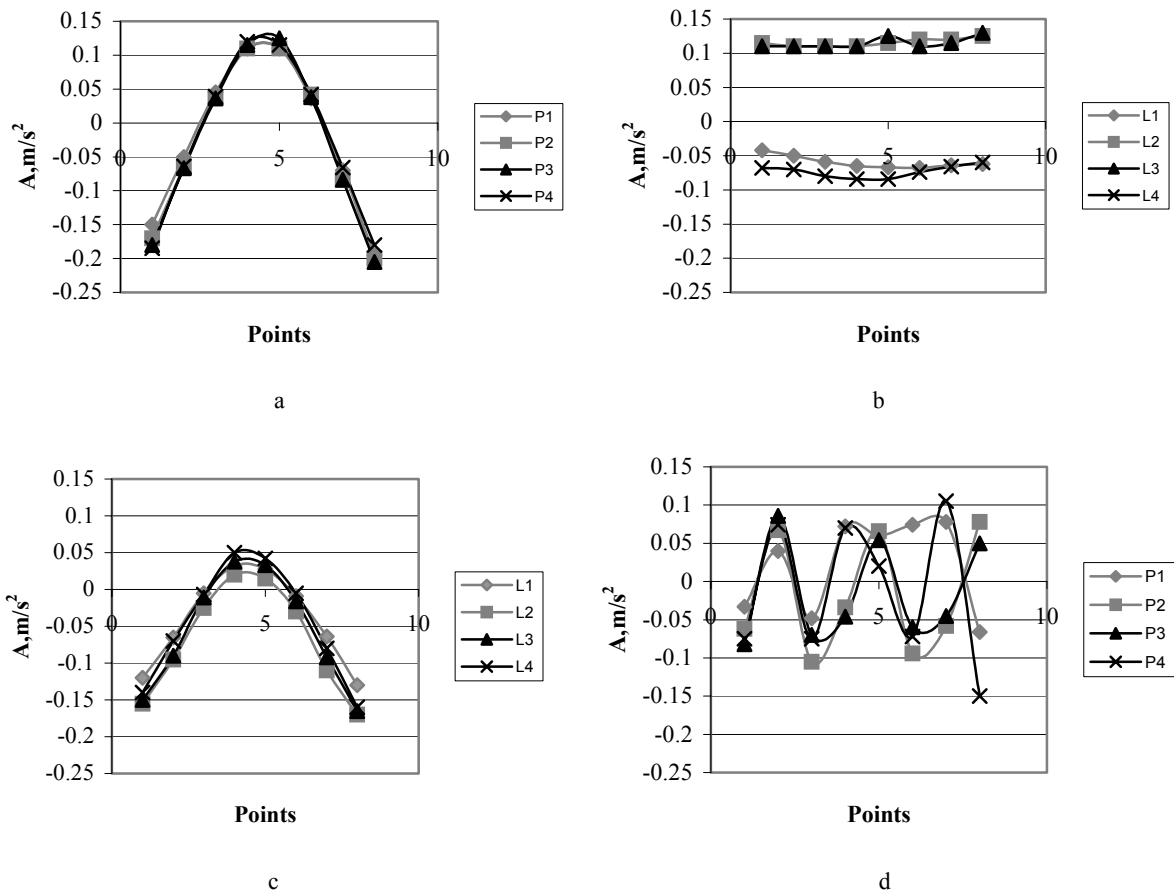

Fig. 5. Regularities of oscillation amplitude variation of points within selected panel strips: a – perpendicularly, $f=93$ Hz; b – longitudinally, $f=93$ Hz; c – longitudinally, $f=235$ Hz; d – perpendicularly, $f=1180$ Hz

middle – different amplitudes ($0.04 - 0.08 \text{ m/s}^2$), or vibration of the whole panel in the same direction has similar amplitudes (Fig. 5, a, c). Similar results are obtained also under frequencies of 430, 500 Hz. However, in most cases, and especially under higher frequencies (Fig. 5, d), amplitudes of the strips are different, the forms of panel bending are complex and greatly differ from theoretical forms of solid plates.

To study the effect of possible low – quality gluing and other defects, a defect in the panel was imitated by making an incision in the gluing zone (Fig. 6). The length of 1.5 mm wide incision varied from 50 to 650 mm, making incisions every 50 and 100 mm and recording the forms of panel bending. 15 resonance frequencies of the panel were recorded without incision. Increasing incision, the number of resonance frequencies augmented to 27. It was found, that most resonance frequencies, having made an incision, decreases by 10 – 15 %. e. g., the frequency of 500 Hz decreases to 438 Hz (when incision length was 150 mm, resonance frequency of the panel – 470 Hz (Fig. 7, b)), that of 700 to 632, 840 – to 780, although the bending form did not change. In some cases, increasing incision length, resonance frequency remained constant, however, the amplitude of oscillations was changing (235, 265 Hz).

Increasing length of incision led to the changes in oscillation amplitudes. The obtained results (Fig. 8) show, that vibration of the panel has the smallest amplitude when the length of incision comprises approximately one half of

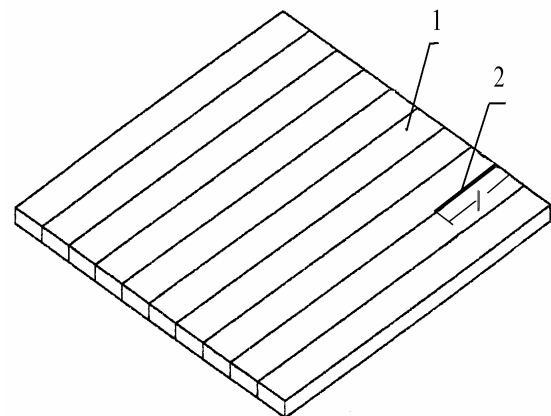

Fig. 6. Scheme of defect imitation in the panel: 1 – panel, 2 – incision, l – length of the imitated defect

the panel length. E. g., when the incision length was 50, 100, 150 mm under 265 Hz frequency, the amplitude was $0.2 - 0.36 \text{ m/s}^2$. Similar to zone B results were obtained in zones C and D.

According to the ascertained resonance frequencies in perpendicular and longitudinal directions, by the equation (5) the modulus of panel elasticity were estimated. It was found, that longitudinally $E_i = 12000 \text{ MPa}$, perpendicularly $E_s = 1600 \text{ MPa}$ (Fig. 9). Having compared with reference sources (for oak it is within 8300 – 16100 range [10]) it can be seen, that modulus of elasticity of the whole panel in longitudinal direction corresponds to the modulus of

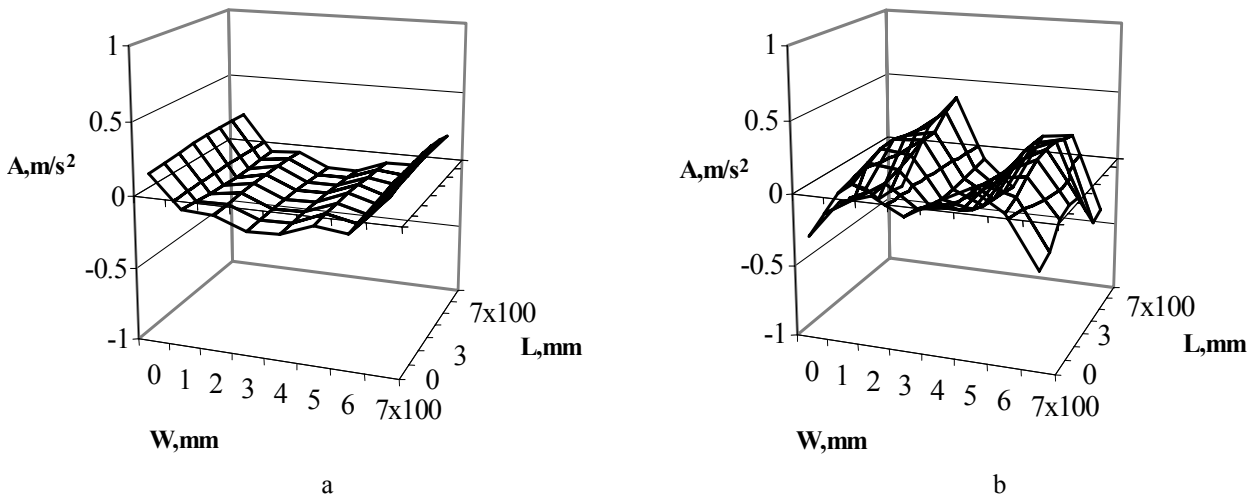

Fig. 7. Bending forms of the studied panels: a – incision 50 mm, $f = 93$ Hz; b – incision 150 mm, $f = 470$ Hz

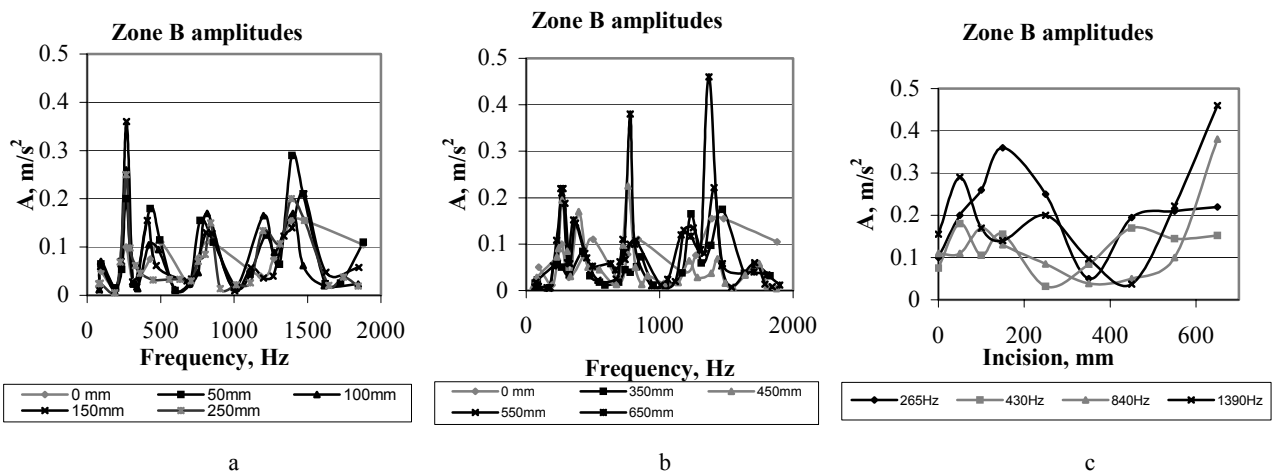

Fig. 8. Variation regularity of oscillation amplitude under changing defect size in one of the panel points (B): a, b – effect of incision in the studied frequency range; c – variation regularities of the amplitude under characteristic frequencies.

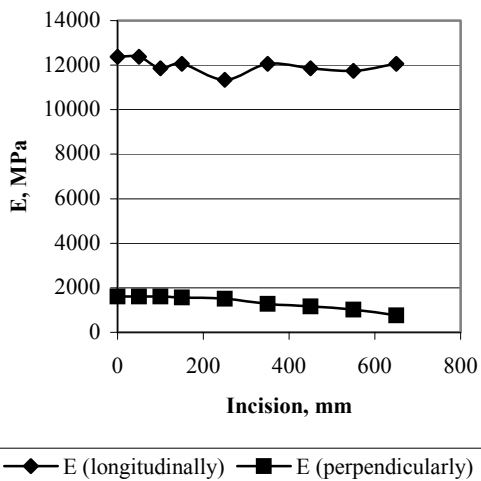

Fig. 9. Dependence of panel elasticity modulus on the defect size elasticity of solid wood. Besides, having made an incision, modulus of elasticity in this direction practically remained constant.

As wood is an anisotropic material, Poisson's ratio both in radial and tangential directions differs. Estimating modulus of elasticity in perpendicular direction, an arithmetical mean of the ratios was accepted as Poisson's

ratio in radial and tangential directions (it was found, that annual rings of most scantlings and the surface of the panel comprise an angle of 45°). Modulus of elasticity of the panel in perpendicular direction, is lower, as well as that of solid wood. With increasing incision length, modulus of elasticity in perpendicular direction evenly decreases. When the length of incision was 650 mm, $E_s = 761$ MPa.

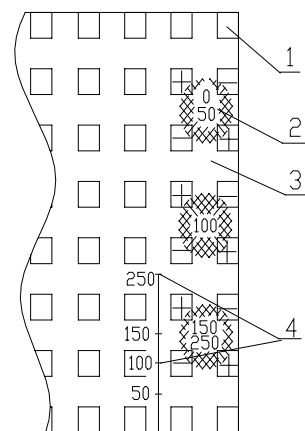

Fig. 10. Variation of the phase of vibrations in the "cut" section of the panel: 1 – fixing place of the measuring element; 2 – place of combination of phases ($\pm \pi$) under a certain incision length, 3 – panel, 4 – incision length, mm

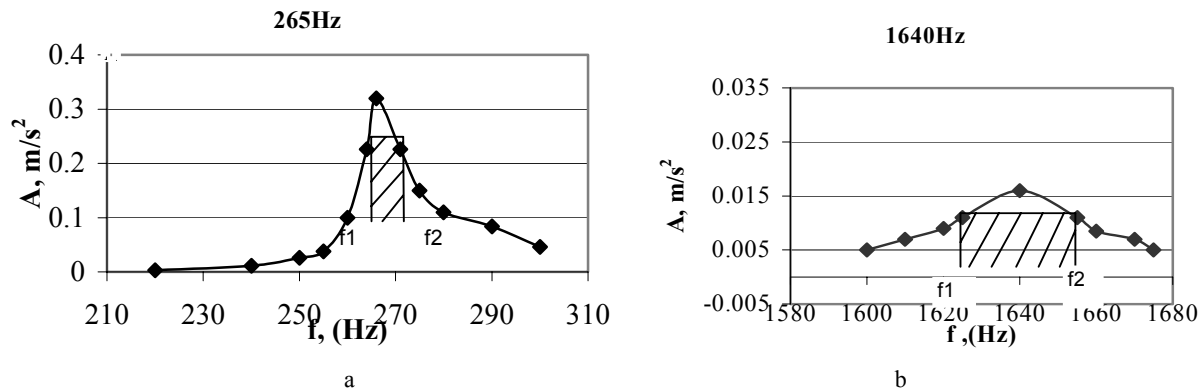

Fig. 11. Amplitude – frequency characteristics of the panel under different bending forms: a – $f_r = 265$ Hz, b – $f_r = 1640$ Hz

Measuring the phase of panel vibrations, precise forms of the studied panel bending were obtained. Variation of the phase was especially distinct having made a defect in the panel.

In case when length increases, it was recorded, that in the “cut” section of the panel under the same panel bending form (without incision $f = 840$ Hz) the phase of oscillations was regularly towards the incision (Fig. 10). When the incision was small (50 mm), the combination of phases ($\pm \mp$) was recorded in the second and third lines of measuring element fixing places. Here “+” means that in this zone the direction of panel vibrations coincides with the direction of the generator’s signal, while “–” means an opposite direction of vibrations of the panel zone to the direction of generated signal. Having made a 100 mm incision, this combination moved to the fourth and fifth lines, while when the length of incision was 150–250 mm, combination of these phases was recorded in the sixth and seventh lines.

The coefficient of damping was evaluated as well [6]. Having recorded resonance frequency f_r and amplitude, later, adjusting the frequency of the generator, two other frequencies f_1 and f_2 are obtained, when the resonance amplitude decreases $\sqrt{2}$ times (Fig. 11). The ratio of strip width $\Delta f = f_1 - f_2$ and resonance frequency f_r characterizes the coefficient of damping.

It can be seen, that even a small defect can cause obvious changes in amplitude–frequency characteristics of the whole panel. In this way it is also possible to ascertain other defects, e.g. knots, interior splits, unglued zones.

Therefore, using resonance oscillations it is possible to estimate mechanical parameters of scantling panels and assess different panel defects.

CONCLUSIONS

1. Panel modulus of elasticity in the longitudinal direction to fibres (gluing solid scantlings), as compared to modulus of elasticity perpendicular to fibres, is higher by about 7.5 times.

2. Introduction of a defect leads to the changes in amplitude – frequency characteristics of the whole panel.

3. Increasing the length of a defect, in most cases bending form of the panel remains constant, only

resonance frequency decreases. In other cases, amplitude changes as well, and slightly the form of bending.

4. Increasing the length of defect longitudinally to glue line direction, the value of modulus of elasticity longitudinally to fibres fluctuates within 8 % range, while perpendicularly to fibres – decreases to 47 %.

5. The least amplitude of panel vibrations is obtained when the length of incision comprises approximately one half of the panels length.

REFERENCES

1. Regeneration, Tending, Protection and Formation of Oak Stands *Standards of Wooden Panels. Information Leaflet ISSN 1392 – 3870* 19 (2) 2002: 43 p. (in Lithuanian).
2. Cai, Zhiyong, Hunt, M. O., Ross, R. J., Soltis, L. A. Static and Vibration Modulus of Elasticity of Salvaged and New Joists *Forest Products Journal* 50 (2) 2000: pp. 35 – 40.
3. Lam, F., Barrett, J. D., Nakajima, S. Engineering Properties of Hem – Fir Used in Japanese Post and Beam Housing *Forest Products Journal* 51 (5) 2001: pp. 79–87.
4. Molin, N. E., Lindgren, L. E. Parameters of Violin Plates and Their Influence on the Plate Modes *Journal Acoustical Society of America* 83 (1) 1988: pp. 281 – 291.
5. Cai, Z., Ross, R. J., Hunt, M. O., Soltis, L. A. Pilot Study to Examine Use of Transverse Vibration Nondestructive Evaluation for Assessing Floor Systems *Forest Products Journal* 52 (1) 2002: pp.89 – 93.
6. Vobolis, J., Dragašiūtė, N., Aleksiejūnas, M., Albrektas, D. The Investigation of Dynamical Parameters of Polymers by Vibrations *Journal of Vibroengineering* 9 (2) 2002: pp. 23 – 30.
7. Wang, X., Ross, R. J., Mattson, J. A., Ericson, J. R., Forsman, J. W., Geske, E. A., Wher, M. A. Nondestructive Evaluation Techniques for Assessing Modulus of Elasticity and Stiffness of Small – Diameter Logs *Forest Products Journal* 52 (2) 2002: pp. 79 – 85.
8. Skucik, E. Simple and Complex Vibratory Systems. Moscow, Mir, 1971: 558 p. (in Russian).
9. Vainberg, D. Reference Book of Strong, Stability and Oscillations of Panels. Kiev, Budivel'nik, 1973: 488 p. (in Russian).
10. Novoderzkin A. Materials Science. Moscow, Mir, 1971: 264 p. (in Russian).

