

A Multiscale Approach to Deformation and Fracture of Heat-Resistant Steel Under Static and Cyclic Loading

Pavlo MARUSCHAK^{1*}, Denys BARAN¹, Vladimir GLIHA²

¹ Ternopil Ivan Pul'uj National Technical University, Ruska str. 56, 46001, Ternopil, Ukraine

² University of Maribor, Smetanova str. 17, 2000, Maribor, Slovenia

crossref <http://dx.doi.org/10.5755/j01.ms.19.1.3821>

Received 30 May 2011; accepted 17 March 2012

Regularities of static and cyclic deformation, damage and fracture of heat-resistant steel 25Kh1M1F, based on the approaches of physical mesomechanics and 3D interferometry method, are presented in this paper. The applicability of these techniques for different hierarchy levels of deformation was studied. The investigation of scanning microscope photos was conducted for several dissipative structures, fragmentation of the material, localisation of macrodeformation and subsequent failure on macro- and mesolevel. It is shown that the used modern techniques of experimental analysis are very efficient in understanding deformation and damage evolution in materials.

Keywords: fracture, heat-resistant steel, cyclic loading, fatigue, plastic deformation.

1. INTRODUCTION

The synergetic principles of physical mesomechanics require that a deformed solid body is considered as a multilevel hierarchical system [1]. Static deformation causes accumulation of defects in the material. Every structural level is characterised by a certain type of the defect-carrier of plastic deformation [2]. With an increase in the degree of plastic deformation the scale level of the material involvement in the deformation process also increases. Under cyclic loading the kinetics of damage accumulation and subsequent failure of the material is determined by the regularities in its structural degradation [2–4].

Cyclic yielding of the material causes the increased density of dislocations on the boundaries of the pearlitic grains and in the vicinity of inclusions. This process is also a complex and multistage hierarchical phenomenon, which can be analysed at several structural levels [5].

The purpose of this work is to assess the structural levels of deformation of heat resistant steel 25Kh1M1F under static and cyclic loading.

2. RESEARCH TECHNIQUE

Cylindrical specimens with diameter $\varnothing = 5.0$ mm from heat resistant steel 25Kh1M1F were cut out of a roller produced at the Ilyich Iron and Steel Works of Mariupol. Cutting was performed in the longitudinal direction near the cooling outlet, Fig. 1. Nominal alloy composition is C – 0.25; Cr – 1.0; Mo – 1.0; and V – less than 1.0 in weight percent, servo-hydraulic test machine under the following loading conditions: frequency $f = 1$ Hz. $\sigma_{max} = 500$ MPa, $\sigma_{min} = 0.1\sigma_{max}$ [6].

The structure of the material corresponded to that of the continuous casting machine (CCM) roller in the initial state. The ZD-100Pu experimental setup with the computer-based measurement system was used to load

specimens under equilibrium deformation conditions up to the stage preceding the initiation of a microcrack.

After a certain number of cycles specimens were taken out of the test machine and their surface was investigated using the REM-106I scanning electron microscope.

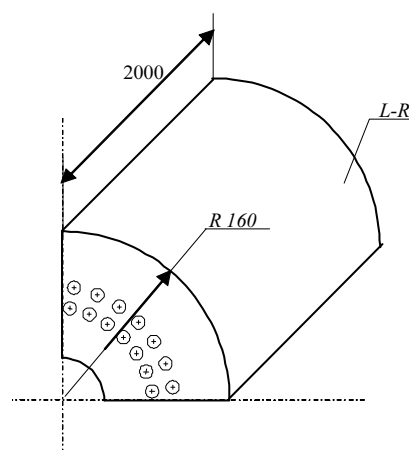

Fig. 1. Scheme for cutting cylindrical specimens from a CCM roller

This allowed for a detailed investigation of the specimen surface structure after various numbers of cycles at different scale levels [6].

3. MICROSTRUCTURE AND DESCRIPTION OF STATIC DEFORMATION OF HEAT RESISTANT STEEL

The metal of CCM rollers from steel 25Kh1M1F was subjected to forging, mechanical and thermal treatment. Banded and individual non-metallic inclusions elongated in the direction of deformation during forging were found in it. Steel 25Kh1M1F had a ferritic-pearlitic structure with fine inclusions of dispersoids, Fig. 2.

The absence of residual stresses, energetically favourable shape, and isolated inclusions ensure high mechanical properties of ferritic-pearlitic steel 25Kh1M1F [7].

* Corresponding author. Tel.: +352-253509; fax.: +352-254983.
E-mail address: maruschak.tu.edu@gmail.com (P. Maruschak)

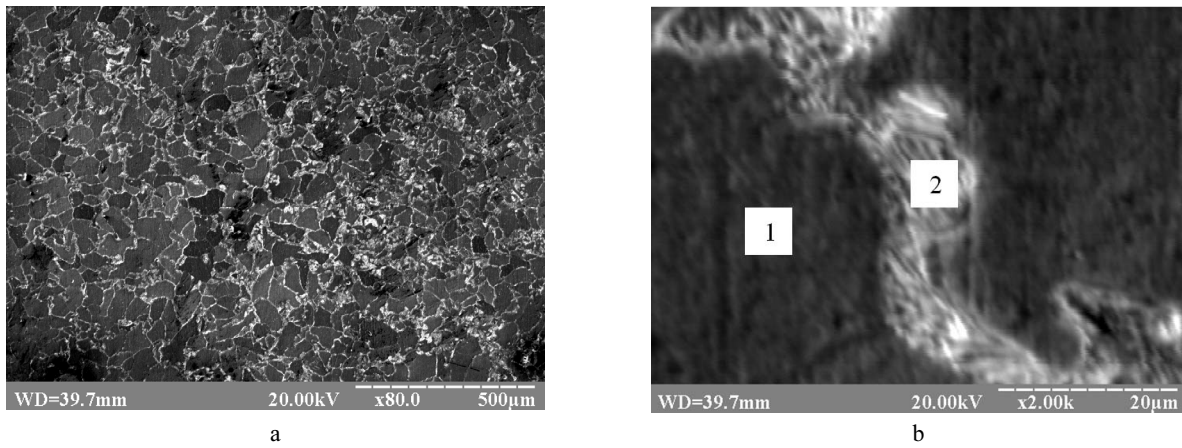

Fig. 2. Images of surface structure of steel 25Kh1M1F (a, b) (1 – ferrite; 2 – pearlite)

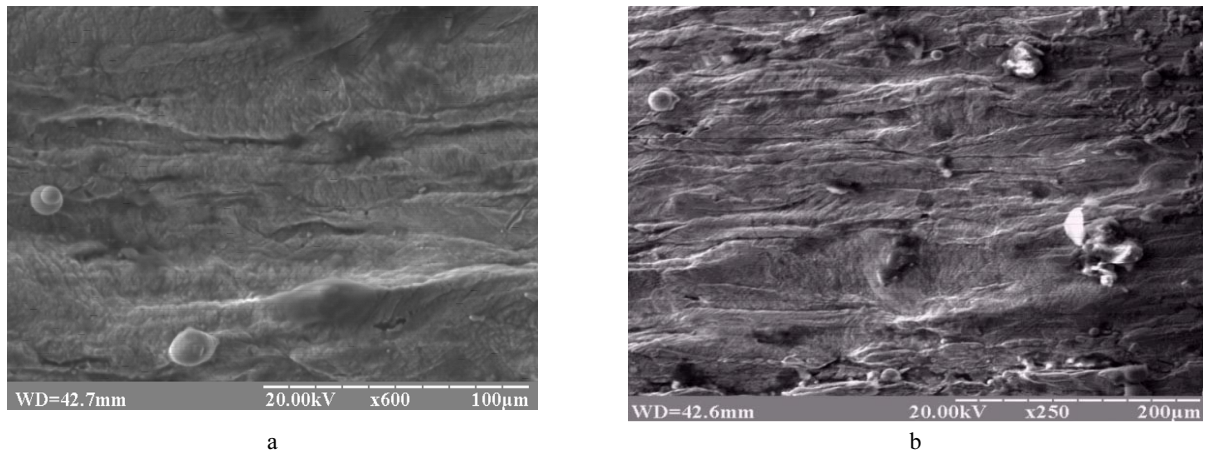

Fig. 3. Mesobands on the surface of a statically deformed specimen from steel 25Kh1M1F ($\varepsilon = 22\%$)

Based on the principles of fracture mechanics and physical mesomechanics the processes of static deformation were considered as a multilevel hierarchical system, in which the processes of local loss of shear stability at the micro-, meso- and macrolevels are interdependent [1, 8]. Due to the structural non-uniformity of the material its plastic deformation is non-homogeneous along the specimen cross-section, plastic yielding in the vicinity of stress concentrators causes the initiation of defects of various scale levels. The change in the density of dislocations indicates the localisation of plastic strains at the macrolevel [9]. At higher structural levels the localization occurs in the form of bands, Fig. 3.

Figure 3 readily illustrates the blocking role of the mesobands in the propagation of the channeled local strain. The coordinated plastic shears in mesobands of the localised material yielding are the defining mechanisms of deformation of the materials studied under static tension. The character of the band width variation determines the load-bearing capacity of the material at various stages of plastic deformation. It is known that the general deformation of the specimen is the sum of specific increments from individual sources of deformation localisation [7]. Thus, the entire deformation increment of the specimen is concentrated within the sections of deformation localisation [1, 3]:

$$\delta\varepsilon \approx \frac{\delta L}{L} \approx \frac{\sum_{i=1}^N \varepsilon_{xx}^{mag} l}{L} \approx N \langle \varepsilon_{xx} \rangle \frac{l}{L}, \quad (1)$$

where N is the number of the active sections of localised deformation with length l in the specimen; ε_{xx}^{mag} is the amplitude of components of the plastic strain tensor ε_{xx} within the section; $\langle \varepsilon_{xx} \rangle l$ is the averaged elongation within the section; L is the specimen length.

The occurrence of mesobands in the specimen material is accompanied by the shear of grain conglomerates and is accommodated due to the turn of adjacent mesovolumes. It is known that each mesovolume forms a new stress concentrator, whose relaxation causes further broadening of mesobands.

The ultimate state of the material is attained due to the nucleation and coalescence of pores, which appear within internal layers of the specimen neck [10]. The scheme of pores nucleation and the image of the pores detected in the material before failure are given in Fig. 4, a.

The channeled plastic strain in the specimens neck studied in the work is fully consistent with the basic concepts of fracture mechanics and mesomechanics [1, 2, 11]. The pores coalesce within the area located normally relative to the loading axis of the specimen. The 3D interferometric method was used to detect local plastically deformed zones in the vicinity of the macrocrack, which are characterised by topographic singularity, Fig. 4, b.

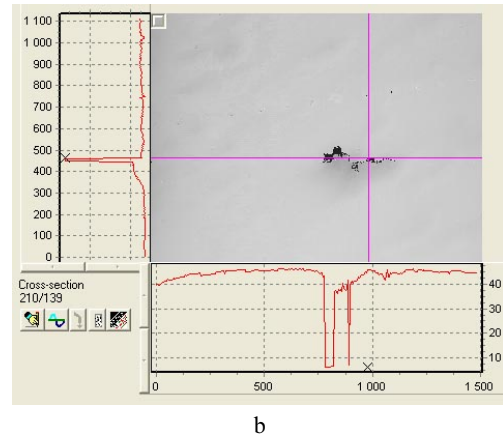
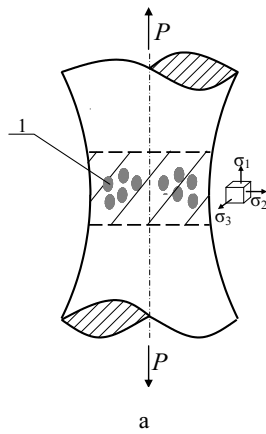

Fig. 4. Scheme of deformation localisation under static tension (a) and pores detected in the specimen neck (b) at $\varepsilon = 24\%$

4. CYCLIC LOADING OF SPECIMENS

4.1. Deformation loops

Figure 5 shows the cyclic deformation loops in the “stress-strain” coordinates. As is seen from their geometry, the process of the low-cycle loading is characterised by quite a complex character of changes in stresses and strains. In addition, plastic damage accumulates in the material. It should be noted that in this case the damage of steel 25Kh1M1F may be caused both by the fatigue mechanisms and the processes of directional plastic deformation [12]. Let us consider the shapes of the mechanical hysteresis loops of the material studied, Fig. 5.

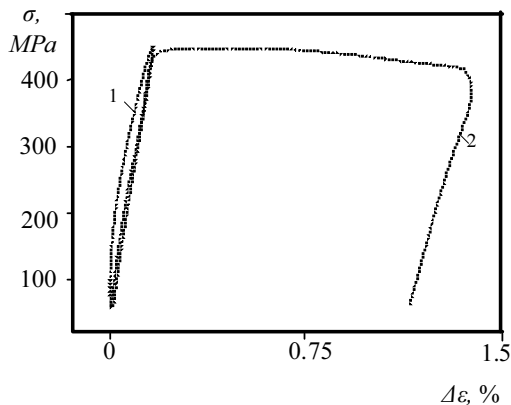

Fig. 5. Cyclic stress-strain curves for steel 25Kh1M1F subjected to different numbers of loading cycles: $N = 2$ (1) and $N = 200$ (2)

The initial period of cyclic loading is characterised by practically closed cyclic deformation loops (1), whereas close to the fatigue limit ($N = 200$ cycles) the value of plastic deformation increases significantly (2), which testifies to the intensive accumulation of fatigue damage. In this case the fatigue damage means loosening (a loss of the material continuity at the microlevel) [13].

It is typical for steel 25Kh1M1F that the material deforms without the initiation of microcracks during the greater number of cycles; large discontinuities of the material occur not long before failure. The cyclic life of specimens was $N = 246$ cycles.

4.2. Cyclic damage accumulation mechanisms

It is known that cyclic deformation of the material at the mesolevel leads to the shear of voluminous structural

elements (grains and their conglomerates) by the “shear + turn” scheme. It is shown that in the structurally non-uniform medium a mechanical circuital field occurs under load, which causes large local bending–rotation effects. This effect is described by the expression for the variation in time of the distortion tensor component gradient [1]:

$$\left[\text{rot } S^\alpha \right]_\mu = \frac{\partial R_\mu^\alpha}{\partial t}, \quad (2)$$

where R_μ^α is the gradient of the component of the bending-torsion distortion tensor.

Local bending–rotation effects generate accommodative flows of rotary defects. Under the uniaxial cyclic tensioning of specimens from steel 25Kh1M1F differently oriented intragranular shears were observed on the material surface, as well as the bands of intragranular sliding, which appear due to the formation of rectilinear gatherings of dislocations [14]. As follows from literature [1, 2, 12], these processes are preconditioned by the intensive plastic deformation, which develops in grains due to the relaxation of microstresses. In our opinion, the formation of the fragmented microstructure is a result of blocking microplastic deformation by grain boundaries [15]. Sliding lines appear in grains already after the first several cycles, Fig. 6, a. A longer duration of cyclic loading leads to a sharper contrast of lines; the earlier formed lines broaden, Fig. 6, b.

Another quite bright effect is the intragranular shear of grains (slippage, turning, climbing), which is observed during delineation of boundaries and the formation of the surface cyclic loading [16]. This shear of grains causes a clearer microrelief. Under significant cyclic loading the slippage of grains across boundaries, migration of grains is no longer an effective mechanism of microstress relaxation, Fig. 6, b. In this case, the periodically distributed micropores occur in the maximum deformation localisation zones (predominantly on grain boundaries). Later they determine the orientation of sliding bands in conjugated directions of the maximum shear stresses within the grain volume [17].

Further cyclic deformation of the specimen is accompanied by mesoplastic deformation, mutual influence and coordination of individual sliding bands, which form a mesostructure in the grain conglomerate that consists of mesovolumes separately moving by the “shear + turn” scheme (Fig. 6, a, b).

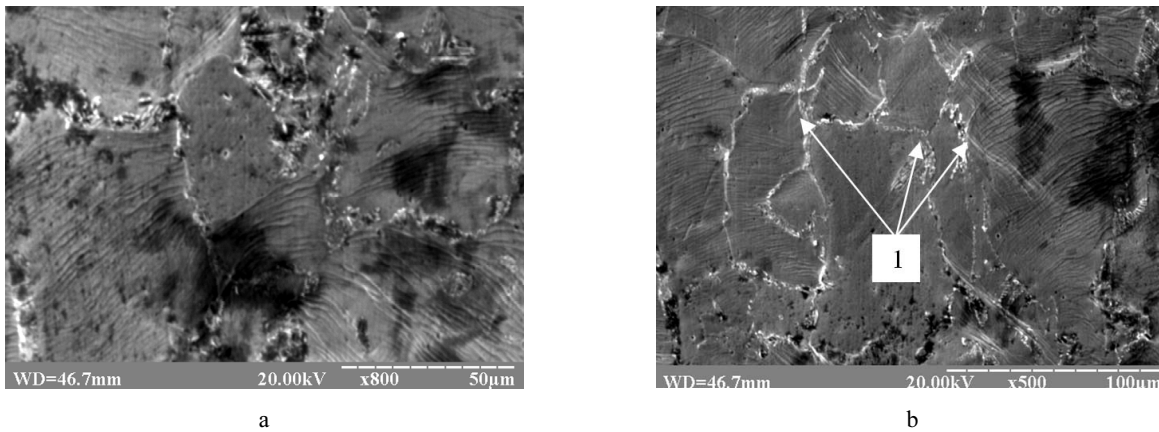

Fig. 6. Structure of boundaries of steel 25Kh1M1F ($N = 200$ cycles) after cyclic loading; 1 – pores; plastic shears and turns of grain conglomerates are pointed with arrows

Apart from the cyclic loading parameters, the regularities of micro- and mesodeformations are affected by the initial microstructure of the material, i. e., the shape and non-uniformity of the spatial distribution of disperse inclusions, density of dislocations in small-angled boundaries, etc. [9]. During cyclic loading the punctual defects migrate to grain boundaries. In this case, plastic shears in the loaded solid body can be considered as a loss of shear stability in the material within the local zones of stress concentrators. The “stochastic” character of the microstructure of polycrystalline materials makes the dispersion of properties at the micro-, meso- and macrolevels inevitable. This preconditions the degradation of most non-homogeneous sections, i. e., grain boundaries in this case, Fig. 6, b.

The role of grain boundaries is different for various structural levels considered. On the one hand (micro- and mesolevel), a grain boundary is a place where deformations of stress concentrators are localised and macrocracks are formed in the surface layer.

If we consider the above processes from the viewpoint of their influence on the macrolevel [18, 19] it should be noted that the redistribution of deformations in local zones of the material is caused by the rough grain boundaries. This aids in the “quasi-homogenisation” of the material properties, hampering of the deformation localisation at the macroscale level, partial relaxation of stresses, elimination of conditions for the nucleation of the main crack. A natural consequence of the intensive internal cyclic micro- and mesodeformation is the macroscopic deformation of the specimen.

4.3. Plastic properties of materials after cyclic loading

Plastic deformation of steel 25Kh1M1F is characterised by formation of mesostructures consisting of bands of localised deformation, which are determined by mesoconcentrators of stresses – i. e., shears of grain conglomerates. It is possible that either the intensity of shears in different sliding systems differs significantly or the sliding systems are differently oriented. This causes the occurrence of strong turning points in the deformed material and leads to the involvement of mesovolumes in the movement.

The observation of the deformation relief evolution on the lateral face of steel specimens allowed determining

physical regularities in cyclic deformation of steel 25Kh1M1F. Apart from the shear of grain conglomerates, the characteristic elements of the deformation relief are folds of the extruded material oriented at an angle of 45° relative to the axis of the external load application (Fig. 7, a, pointed with arrows).

On the material surface a large amount of small shears is formed, whose boundaries are determined by structural elements (grains), the shears propagate in the direction of maximum tangential stresses both at the level of grains and finer structural elements (subgrains), whereas within the coating several macrofragments are formed, whose boundaries are determined by the structure of macrocracks.

The effect of the material plasticity enhancement due to the formation of the localised plastic deformation bands in the material during failure was observed, Fig. 7, a, b. In our opinion, deformation developed by the phase switching wave scheme due to a more intensive deformation development in one or another macroband, Fig. 7, b. Moreover, the increased plasticity of such compositions may be caused by a partial relaxation of stress mesoconcentrators [2]. A system of plastic shears occurred on surfaces of the specimens that failed after cyclic loading, which is due to the shear of grain conglomerates, Fig. 7, c, d.

5. CONCLUSION

Based on the approaches of physical mesomechanics the general regularities of the low-cycle fatigue of specimens from steel 25Kh1M1F under static and cyclic loading are formulated. The concept of the multilevel deformation and failure is shown to adequately describe the kinetics of damage accumulation on the surface of the heat resistant steel investigated.

Under cyclic deformation a well-developed hierarchy of the structural levels of plastic deformation forms in the material, which ensures the self-consistent cyclic deformation of the entire material volume. In this case, sliding develops in the most favourably oriented grains at the initial stage, whose gradient causes the nucleation of local structural mesoturnings in the polycrystal. The development of the accommodative turning mechanisms leads to the occurrence of dissipative structures, fragmentation of the material, localisation of macrodeformation and subsequent failure.

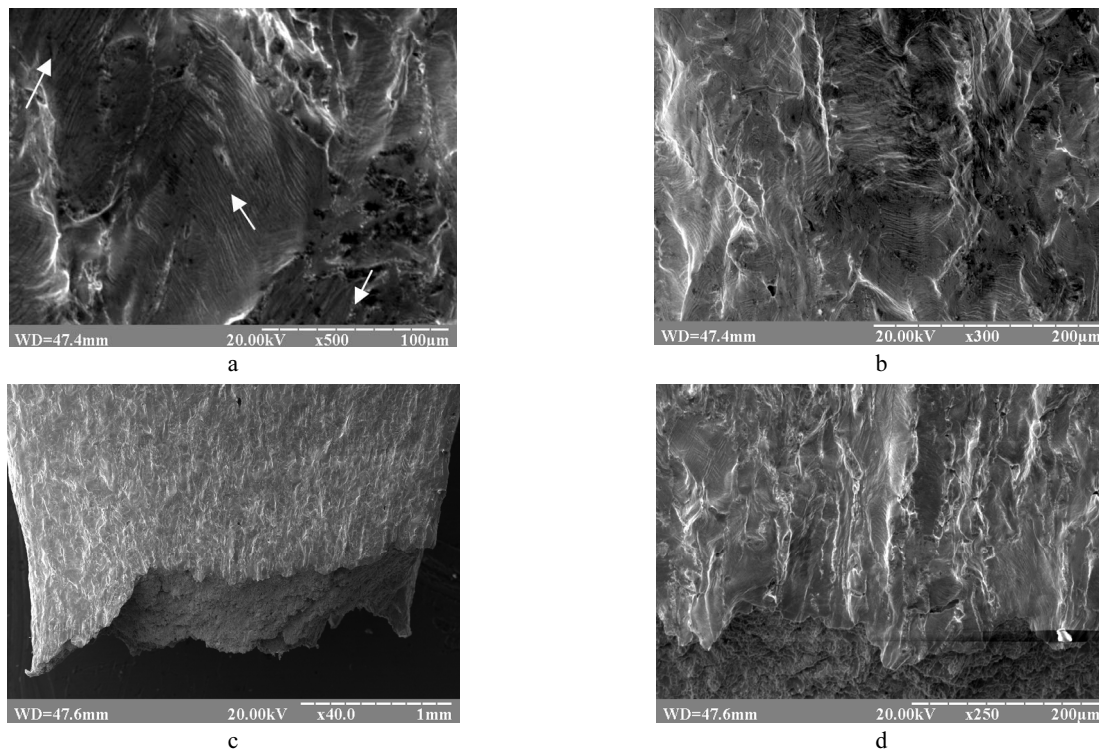

Fig. 7. Mechanisms of deformation and failure of steel 25Kh1M1F ($N = 250$ cycles): a, b – grain shears; c, d – macro- and micro relief of the lateral specimen surface

REFERENCES

- Panin, V. E., Grinyaev, Yu. V., Egorushkin, V. E. Foundations of Physical Mesomechanics of Structurally Inhomogeneous Media *Mechanics of Solids* 45 2010: pp. 501–518.
- Guz, A. N. On Physically Incorrect Results in Fracture Mechanics *International Applied Mechanics* 45 2009: pp. 1041–1051.
- Zuev, L. B., Danilov, V. I., Barannikova, S. A., Gonchikov, K. V., Zykov, I. Yu. On a New Type of Plastic Deformation Waves in Solids *Russian Physics Journal* 44 2001: pp. 169–177.
- Maruschak, P., Hlado, V., Bishchak, R., Pylypenko, A. Influence of Thermocyclic Operation on the Degradation of Properties of a Heat-Resistant Steel *Materials Science* 46 2010: pp. 102–107. <http://dx.doi.org/10.1007/s11003-010-9269-1>
- Yasniy, P., Maruschak, P., Lapusta, Y., Hlado, V., Baran, D. Thermal Fatigue Material Degradation of Caster Rolls' Surface Layers *Mechanics of Advanced Materials and Structures* 15 2008: pp. 499–507. <http://dx.doi.org/10.1080/15376490802142635>
- Kuznetsov, P. V., Petrakova, I. V., Gordienko, Yu. G., Zasmichuk, E. E., Karbovskii, V. L. Formation of Self-Similar Structures On {100}<001> Aluminum Single-Crystal Foils Under Cyclic Tension *Physical Mesomechanics* 12 2009: pp. 85–93. <http://dx.doi.org/10.1016/j.physme.2009.03.011>
- Yasniy, P. V., Maruschak, P. O., Panin, S. V., Bishchak, R. T. Scale Levels of Deformation and Fracture and Mechanical Properties of 25Cr1MoV Steel Before and After Nonisothermal Loading *Physical Mesomechanics* 14 2011: pp. 57–65.
- Čiuplys, A., Vilys, J., Čiuplys, V., Kvedaras, V. Investigation of Dislocation Structure of Low Carbon Steel During Static Loading *Mechanica* 4 (60) 2006: pp. 59–66.
- Yasniy, P. V., Maruschak, P. O., Hlad'o, V. B., Baran, D. Ya. Correlation of the Microdislocation Parameters With the Hardness of Plastically Deformed Heat-Resistant Steels *Materials Science* 44 2008: pp. 194–200. <http://dx.doi.org/10.1007/s11003-008-9077-z>
- Yasniy, P., Maruschak, P., Bishchak, R., Hlado, V., Pylypenko, A. Damage and Fracture Analysis of Heat-Resistance Steel Subjected to Thermal Cyclic Loading *Theoretical and Applied Fracture Mechanics* 52 2009: pp. 22–25.
- Guz, A. N. On Study of Nonclassical Problems of Fracture and Failure Mechanics and Related Mechanisms *International Applied Mechanics* 45 2009: pp. 1–31.
- Yasniy, P. V., Hlado, V. B., Hutsaylyuk, V. B., Vuherer, T. Microcrack Initiation and Growth in Heat-Resistant 15Kh2MFA Steel Under Cyclic Deformation *Fatigue & Fracture of Engineering Materials & Structures* 28 2005: pp. 391–397.
- Yasniy, P., Hutsaylyuk, V. Loading History Influence on the Brittle Fracture Resistance of the Heat - Resistance Steels *Proceedings the 8-th Int. Conf. on the Mechanical Behaviors of Materials* (May 16–21) Victoria, Canada, 1999: pp. 155–159.
- Troshchenko, V. T., Pokrovskii, V. V., Tokarev, P. V., Yasniy, P. V. Fatigue Strength, Laws of Inelastic Deformation, And Microcrack Nucleation in Steel 15Kh2MFA *Strength of Materials* 25 1993: pp. 482–487. <http://dx.doi.org/10.1007/BF00775124>
- Yasniy, P., Maruschak, P., Hlado, V., et al. Non-Destructive Analysis of Heat-Resistant Steel Applied to Continuous Caster Roll After Plastic Deformation *Proceedings of the 5-th Int. Workshop ITELMS'2010* 03–04 June 2010, Panevėžys, Lithuania. Ed's: Ž. Bazaras, V. Kleiza, 2010: pp. 27–30.
- Yasniy, P. V., Glad'o, V. B., Okipnyi, I. B. Relationship Between Rupture Stress and Microstructure Parameters of Plastically Deformed Heat-Resistant Steel *Strength of Materials* 39 2007: pp. 349–357. <http://dx.doi.org/10.1007/s11223-007-0039-8>
- Yasniy, P., Maruschak, P., Hlado, V. Hardening Of Heat-Resistant Steels Under Conditions of Plastic Deformation at Different Temperatures *Computational & Experimental Analysis of Damaged Materials* Ed. Dimitrios Pavlou, Transworld Publishing, 2007: pp. 167–181.
- Daunys, M., Dundulis, R., Karpavičius, R., Bortkevičius, R. Aging Investigation of Metals of the Pipes in Lithuanian Power Station *Mechanika* 17 (1) 2011 pp. 13–20.
- Zielinski, W., Swiatnicki, W., Barstch, M., Messerschmidt, U. Non-Uniform Distribution of Plastic Strain in Duplex Steel During TEM in Situ *Deformation Materials Chemistry and Physics* 81 2003: pp. 476–479.